



iX4-280/380 Series Printer

User Manual



<https://www.argo.com>

Version: 1.2

Liability Disclaimer

Argox Corporation takes steps to assure that the company's published engineering specifications and manuals are correct; however, errors do occur. Argox reserves the right to correct any such errors and disclaims any resulting liability. In no event shall Argox or anyone else involved in the creation, production, or delivery of the accompanying product (including hardware and software) be liable for any damages whatsoever (including, without limitation, damages for loss of business profits, business interruption, loss of business information, or other pecuniary loss) arising out of the use of or the results of use of or inability to use such product, even if Argox has been advised of the possibility of such damages.

FCC Compliance Statement

This equipment has been tested and found to comply with the limits for a Class A digital device, pursuant to Part 15 of the FCC Rules. These limits are designed to provide reasonable protection against harmful interference in a residential installation. This equipment generates, uses, and can radiate radio frequency energy and, if not installed and used in accordance with the instructions, may cause harmful interference to radio communications. However, there is no guarantee that the interference will not occur in a particular installation. If this equipment does cause harmful interference to radio or television reception, which can be determined by turning the equipment off and on, the user is encouraged to try to correct the interference by the following measures:

Reorient or relocate the receiving antenna.

Increase the separation between the equipment and the receiver.

Connect the equipment into a different outlet on a different circuit.

Consult the dealer or an experience Radio/TV technician for help.

This unit was tested with shielded cables on the peripheral devices. Shielded cables must be used with the unit to ensure compliance. The user is cautioned that any changes or modifications not expressly approved by Argox Information Co., Ltd. could void the user's authority to operate the equipment.

This is a Grade A product. In living environment, the product may cause interference to radio communications. In this case, the user is encouraged to try to correct the interference by effective measures.



Caution

Ensure to connect the power cord of power adapter to a socket-outlet with earth connection.

CAUTION: Risk of Explosion if Battery is replaced by an Incorrect Type. Dispose of Used Batteries According to the Instructions.

ATTENTION: Risque d'explosion si la batterie est remplacée par un type incorrect. Mettre au rebus les batteries usagées selon les instructions.

Caution

Any changes or modifications not expressly approved by the party responsible for compliance could void the user's authority to operate the equipment.

All rights reserved. Copyright © 2024 Argox Information Co., Ltd

Contents

1	Introduction	1
1.1	Features	1
1.2	Unpacking.....	2
1.3	Understand your printer	3
1.3.1	Perspective view	3
1.3.2	Back view	3
1.3.3	Interior view	4
1.4	Printer control panel.....	5
1.4.1	Status lights.....	5
1.4.2	Buttons	8
2	Get started	9
2.1	Attach the power cord	9
2.2	Turn on/off your printer.....	10
2.2.1	Turn on your printer.....	10
2.2.2	Turn off your printer	11
2.3	Load media	12
2.3.1	Prepare media	13
2.3.2	Placing media roll.....	13
2.3.3	Media types	24
2.4	Load Ribbon.....	26
2.4.1	Placing Ribbon Roll	27
3	Printer operation	30
3.1	Front Panel	30
3.1.1	LCD Function Setting Procedure.....	31
3.2	Printing Media Calibration & Configuration	37
3.3	Printing a Configuration Report	37
3.4	Restore to Factory Default	44
3.5	Media sensing.....	45
3.5.1	Transmissive sensor	45
3.5.2	Reflective sensor.....	46
3.5.3	Adjust Position of Label Sensor	47
3.6	Communications.....	48
3.6.1	Interfaces and Requirements	48
3.7	Driver installation	50
3.7.1	Installing a Plug and Play printer driver (for USB only).....	50
3.7.2	Installing a Printer Driver (for interfaces Other than USB)	56

4	Configuration on Web Setting Tool	62
4.1	Attaching the power cord	62
4.2	Connecting the printer to a LAN hub	62
4.3	Getting the IP address of the printer	63
4.4	Logging in to the web setting tool	63
5	Maintenance	65
5.1	Cleaning	66
5.1.1	Printhead	66
5.1.2	Platen Roller	67
5.2	Printer Adjustments	68
5.2.1	Printer Head Pressure Adjustment	68
5.2.2	Ribbon Tension Adjustment	70
5.2.3	Printing Wrinkle Adjustment	71
5.2.4	Small-size Media Offset Adjustment	74
5.3	RTC Battery Replacement	75
6	Troubleshooting	76
6.1	Printer issues	76
6.2	Media issues	77
6.3	Ribbon issues	78
6.4	Other issues	79
7	Specifications	80
7.1	Printer	80
7.2	Media & Ribbon	82
7.3	Electrical and operating environment	82
7.4	Physical dimension	83
7.5	Fonts, Barcodes, and Graphics Specification	83
7.6	Wireless LAN (Optional)	86
7.7	Interfaces	88
7.7.1	USB	88
7.7.2	RS-232C	89
7.7.3	GPIO	90
7.7.4	Ethernet	91

1 Introduction

Thank you for purchasing an Argox iX4-280/380 Series industrial barcode printer. This manual provides information about how to set up and operate your printer, load media, ribbon and solve common problems. Illustrations are provided to help you quickly become familiar with the printer.

1.1 Features

- **Fast Print Speed**
 - iX4-280: 10 IPS (Max.)
 - iX4-380: 8 IPS (Max.)
- **Communicatio**
 - Standard: Ethernet, dual USB hosts, USB device, and RS-232
 - Option: Wi-Fi module and GPIO
- **Online management**
 - Web management and SNMP support
- **Dual USB host function**
 - Stand-alone mode of scanner/ keyboard multiple data entry devices
- **New media calibration**
 - Intelli mode & Smart mode

1.2 Unpacking

Make sure all of the following items are included in your package.

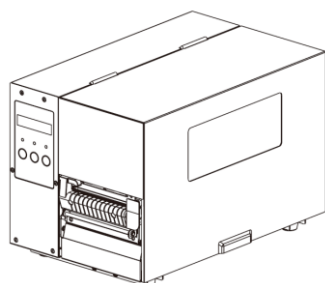

Printer

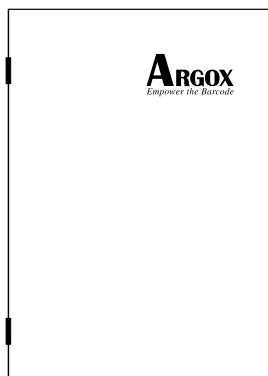

Quick Installation
Guide

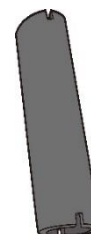

1" ID Core for Ribbon



High-speed Ribbon

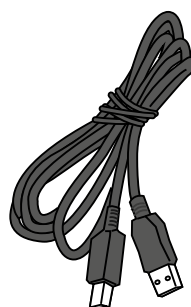

USB Cable

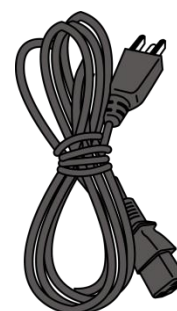

AC Power Cord

When you receive the printer, open the package immediately and inspect for shipping damage. If you discover any damage, contact the shipping company and file a claim. Argox is not responsible for any damage incurred during shipping. Save all package materials for the shipping company to inspect.



Note 1:

If any item is missing, please contact your local dealer.

Note 2:

Argox provides a sample roll of high-speed ribbon in the package of iX4-280/iX4-380. This explains that users must use the appropriate ribbon to achieve the best results when printing with Argox high-speed printers. It also allows users to get a more realistic experience of high-speed printing. Users should note that this high-speed printing experience is only suitable for room-temperature environments.

1.3 Understand your printer

1.3.1 Perspective view

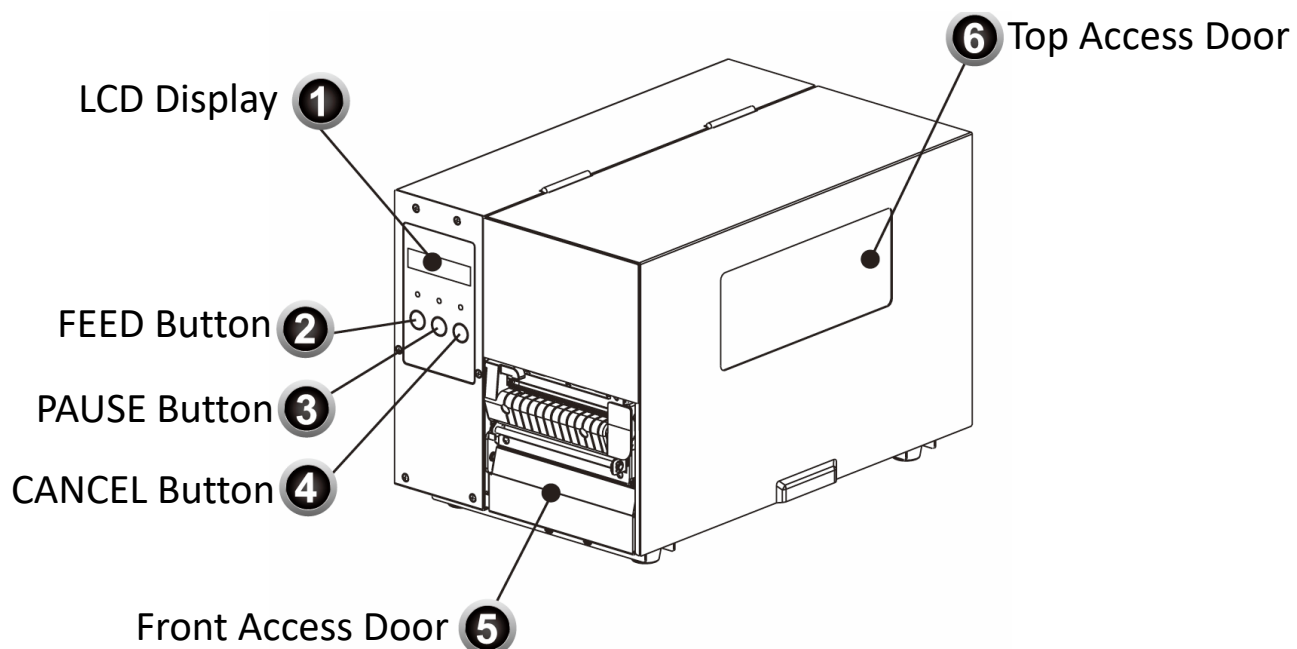

1.3.2 Back view

iX4-280/380 Standard

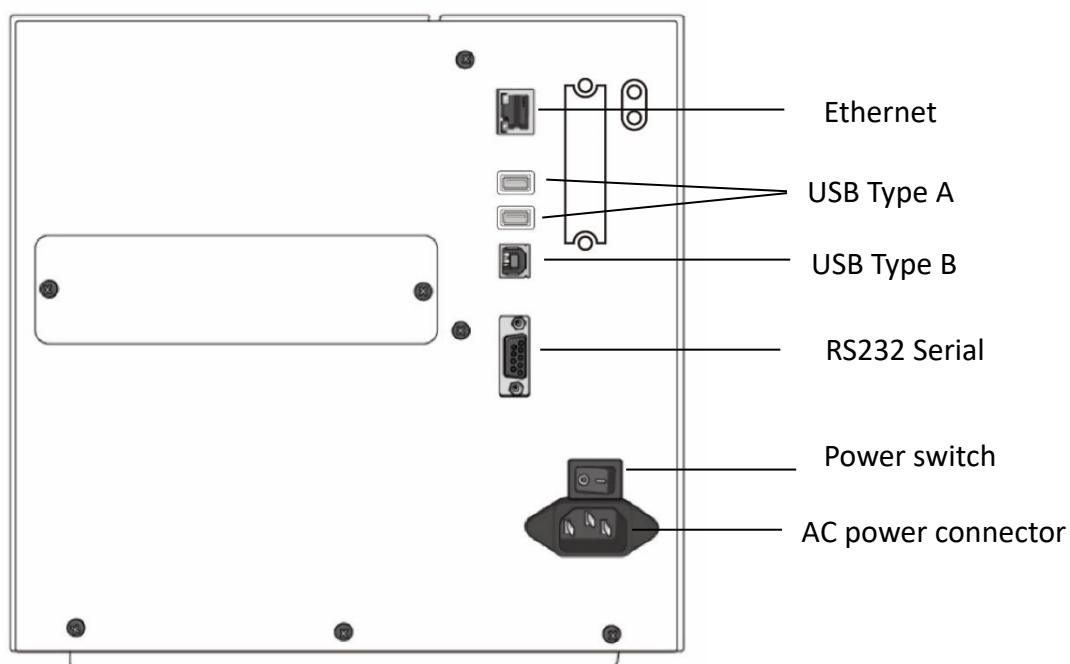

iX4-280/380 Optional

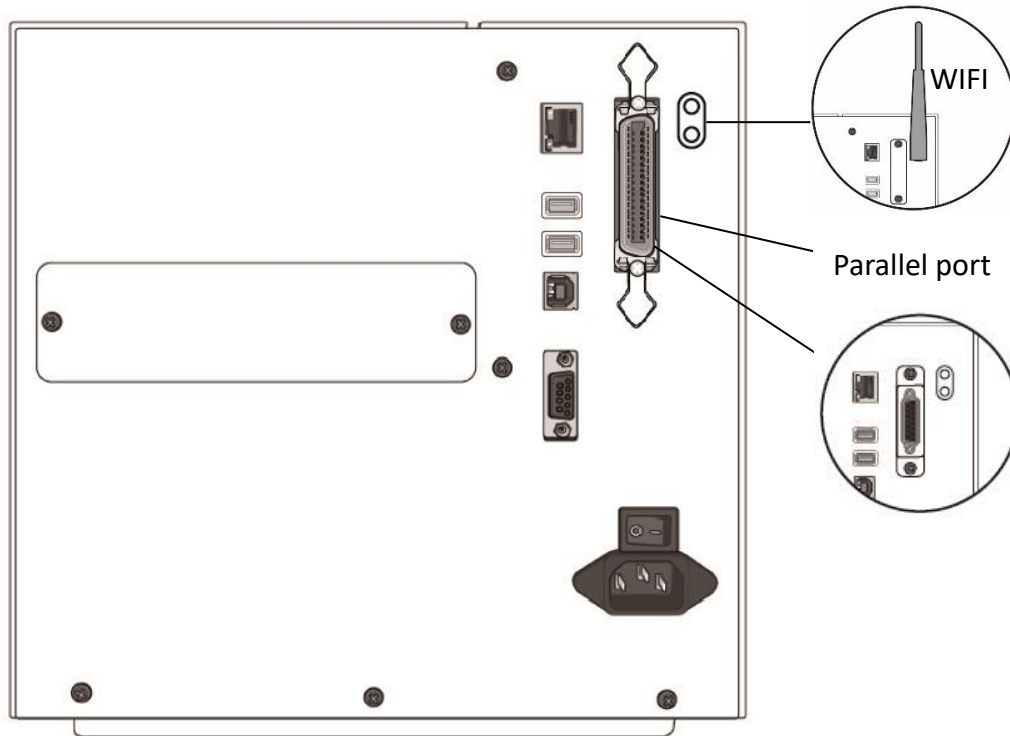

1.3.3 Interior view

Internal Parts and Features

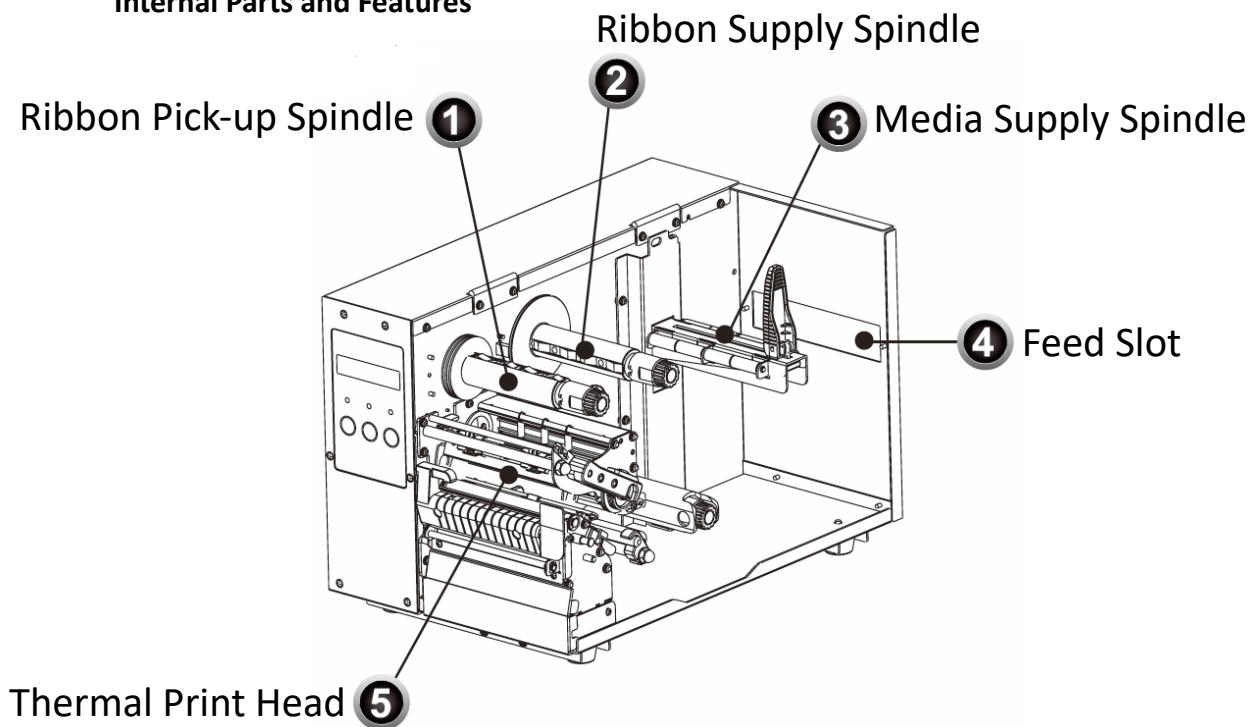

Rotate Head Latch

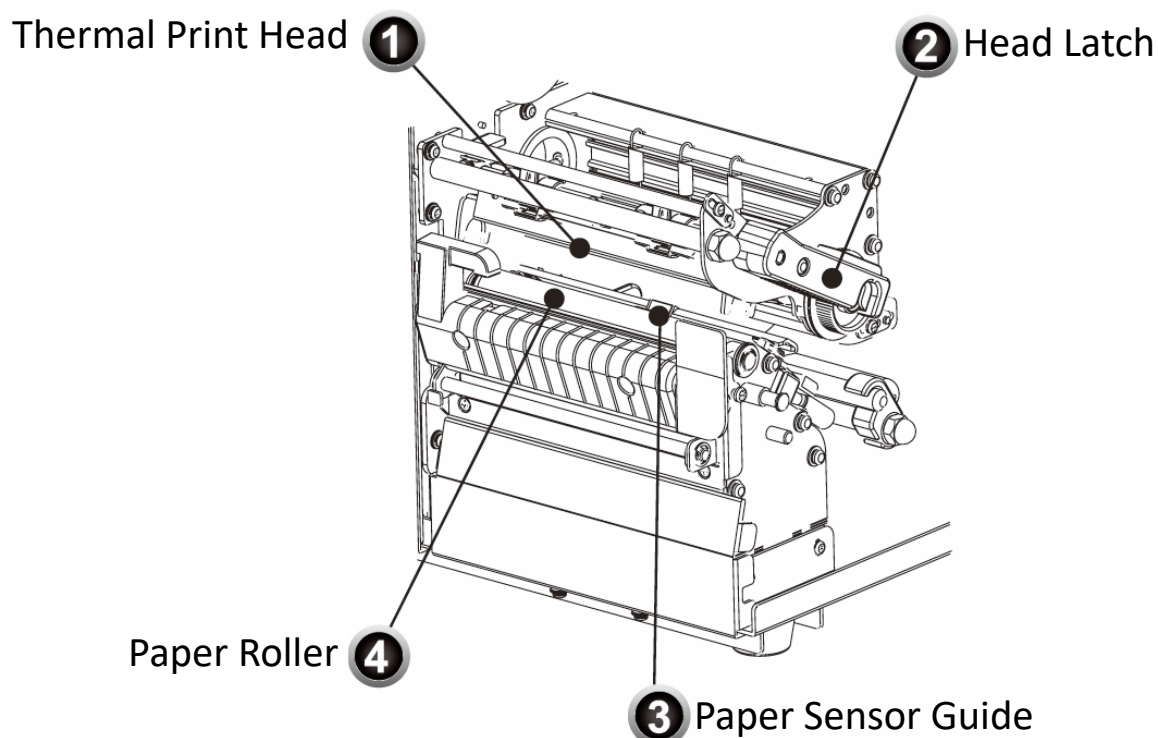

1.4 Printer control panel

There are three lights on the front panel - READY, MEDIA and RIBBON. These indicators display operation status of the printer. Three buttons - FEED, PAUSE, and CANCEL can control printer simple function.

1.4.1 Status lights

Status lights help you check printer's condition. The following tables show the status lights and the conditions they indicate.

LCD Display	READY	MEDIA	RIBBON	Description
READY	ON	ON	ON	In the ready mode
PRINT HEAD HEAT	ON	Blinking	ON	Print head needs to cool down.
COMMAND ERROR	ON	Blinking	Blinking	A command error was found while checking the command sequence.

LCD Display	READY	MEDIA	RIBBON	Description
EEPROM ERROR	ON	Blinking	Blinking	An EEPROM for back-up cannot be read/written properly.
MEMORY ERROR	ON	Blinking	Blinking	<ul style="list-style-type: none"> · An error has occurred in writing data into USB memory or flash memory. · An erase error has occurred in formatting USB memory or flash memory. · Saving failed because of the insufficient capacity of USB memory or flash memory. · Firmware update has error.
CANCEL ...	Blinking	ON	ON	Press CANCEL KEY to interrupt and delete a print task
CLEAR FLASH	Blinking	ON	ON	Clear flash memory.
CUTTER FAILED	Blinking	ON	ON	Cutter has failed, or there is paper jam inside the cutter.
MEMORY FULL	Blinking	ON	ON	Printer buffer is full caused by the loaded soft fonts, graphics or forms.
MEMORY INITIALIZED	Blinking	ON	ON	USB Memory is being initialized.
PAUSE	Blinking	ON	ON	Printer is in PAUSE status. Media sensor cannot index label gaps
PRINthead BROKEN	Blinking	ON	ON	Head broken error
PRINT HEAD OPEN	Blinking	ON	ON	Head latch is not closed.

LCD Display	READY	MEDIA	RIBBON	Description
RESET	Blinking	ON	ON	Press CANCEL KEY + POWER ON to reset NVR table.
SERIAL IO ERROR	Blinking	ON	ON	The format or baud rate of the RS232 communication is inconsistent between the printer and host.
SELF TEST ...	Blinking	ON	ON	Press FEED KEY + POWER ON to print the self-test label.
UPGRADING FW.	Blinking	ON	ON	Printer is receiving data
RIBBON OUT	Blinking	ON	Blinking	Ribbon is not installed or end-of-ribbon occurred.
CALIBRATION . ..	Blinking	Blinking	ON	Press PAUSE KEY + POWER ON to calibrate media.
MEDIA OUT	Blinking	Blinking	ON	Media is not installed or used up. Printer fails to detect the media gap. The media sensor is out of range during calibration. The label has run out. The last label has been issued normally and the label has run out.
PAPER JAM	Blinking	Blinking	ON	A paper jam occurred during paper feed.

1.4.2 Buttons

There are three buttons, each with two basic functions.

Button	Function 1	Function 2
FEED	<ul style="list-style-type: none">• Feed a label	
PAUSE	<ul style="list-style-type: none">• Pause printing	<ul style="list-style-type: none">• Press again to resume printing
CANCEL	<ul style="list-style-type: none">• Interrupt and delete a print task	<ul style="list-style-type: none">• Force printer to continue after an error is solved.

2 Get started

This chapter describes how to set up your printer.

2.1 Attach the power cord

- 1 Ensure the power switch is set to the OFF position.
- 2 Place the printer within cable distance of the host and printer (using a USB or serial cable).
- 3 Keep the power cord isolated from other electrical cables.
- 4 Plug one end of the AC power cord into the power socket on the printer. The power socket is located on the back of the printer.
- 5 Plug the other end of the AC power cord into a wall outlet. Make sure the wall outlet and the printer have the same voltage and frequency, otherwise you may damage or explode the printer.

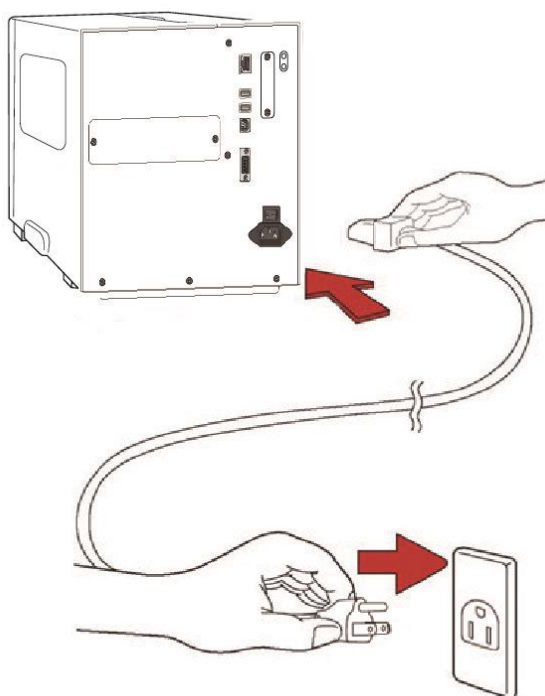

Warning Do not plug the AC power cord with wet hands, or operate the printer and the power supply in an area where they may get wet. Serious injury may result from these actions!

2.2 Turn on/off your printer

When your printer is connected to a host (a computer), it is good to turn on the printer before turning on the host and turn off the host before turning off the printer.

2.2.1 Turn on your printer

- 3 To turn on your printer, turn on the **Power Switch** as below. The “I” is the **ON** position.

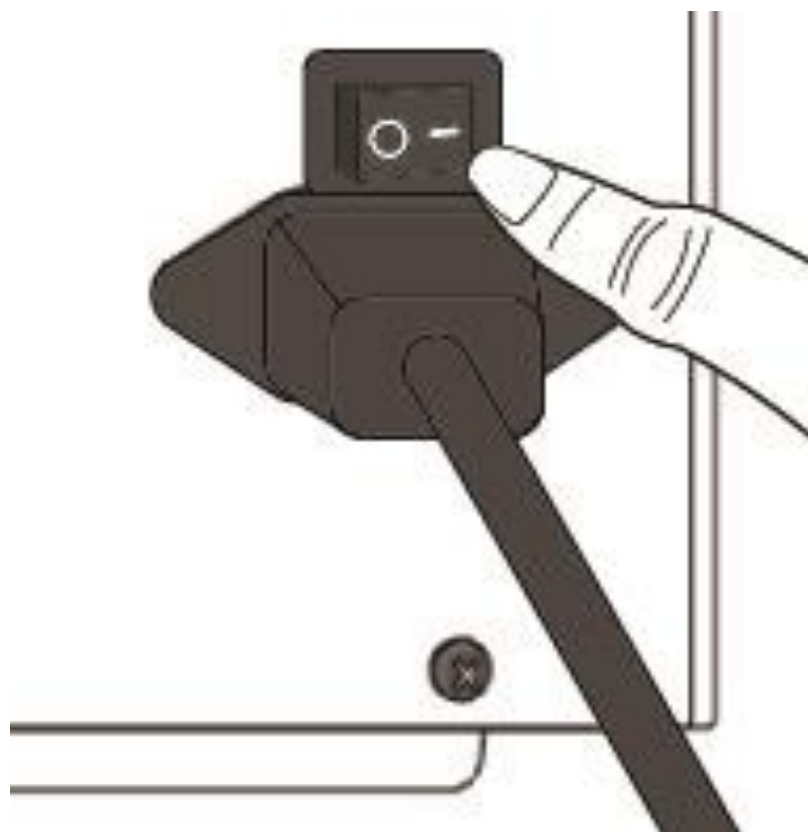

- 4 READY, MEDIA, and RIBBON LED stay solid blue. Then the READY LED will turn off for a few seconds while the LCD screen displays the firmware version. The LCD will display Ready to Print and the READY LED will return to solid blue.

2.2.2 Turn off your printer

1. Make sure that READY, MEDIA, and RIBBON are solid blue before turning off the printer.
2. To turn off your printer, turn off the **Power Switch** as below. The “O” is the **OFF** position.



Caution Do not turn off your printer during data transfer.

2.3 Load media

The iX4-280/380 printer offers three different loading modes: standard, peel-off, and cutter.

- **Standard mode** allows you to collect each label freely.
- **Peel-off mode** peels backing material away from the label as it prints. After the label is removed, the next label prints.
- **Cutter mode** automatically cuts the label after it prints. There are rotate cutter and guillotine cutter types to cut media.



IMPORTANT When using the Peeler Mode and Cutter Mode for the first time, be sure to enable the PEELER INSTALLED or CUTTER INSTALLED setting on the front panel. For more information about the panel setting, see CH 3.1.1 LCD Function Setting Procedure.

Thermal Transfer Media Loading Instructions

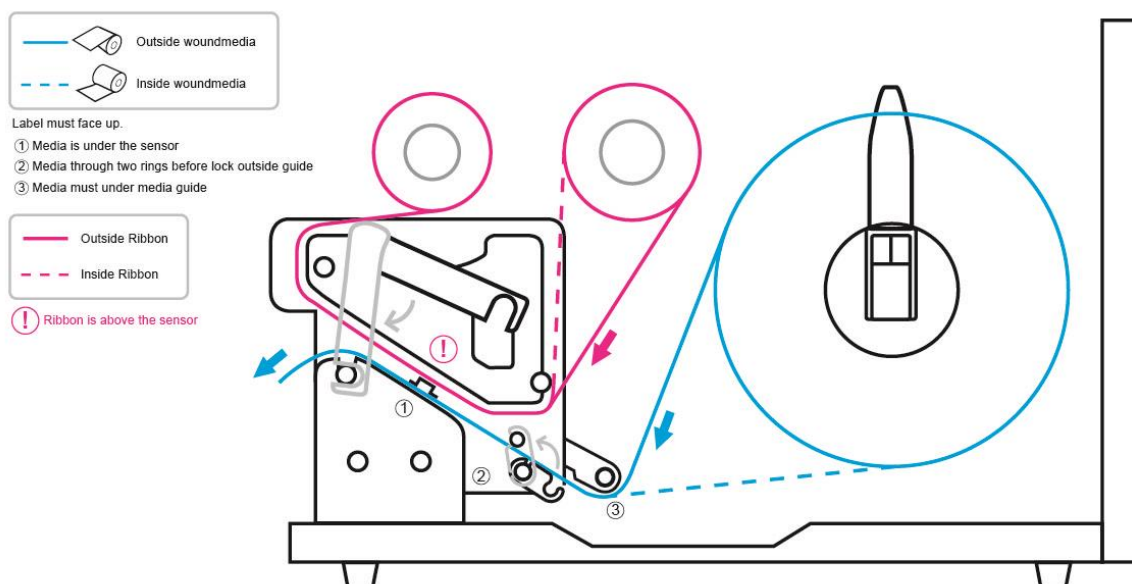

2.3.1 Prepare media

The media roll can be loaded into the printer in the same manner for both inside and outside wound media. In case the media roll is dirty during shipping, handling, or storage, remove the outer length of the media. It helps avoid dragging adhesive and dirty media between the printhead and platen roller.

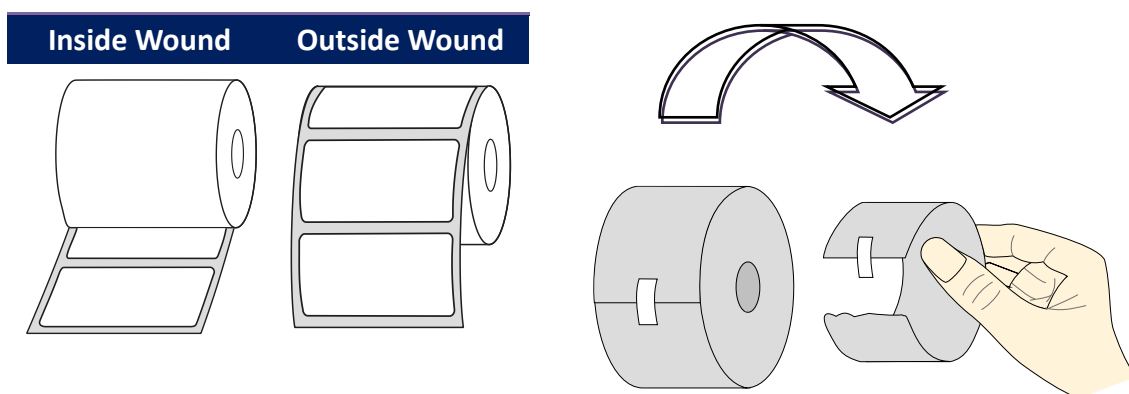

2.3.2 Placing media roll

Load Media In Standard Mode

- 1 Lift the top cover to expose the media compartment.

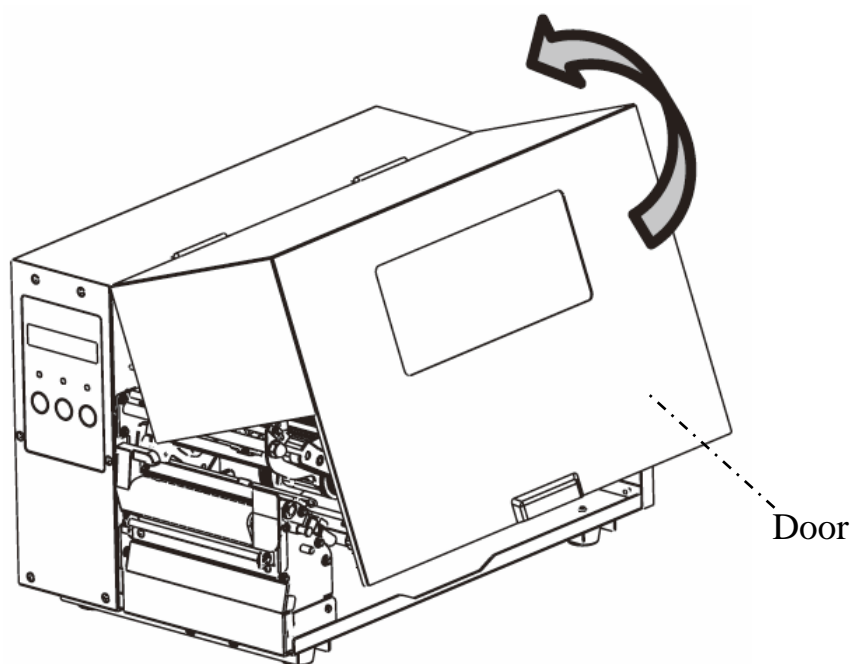

- 2 Insert the media roll into the media supply spindle and slide the media guide inward.

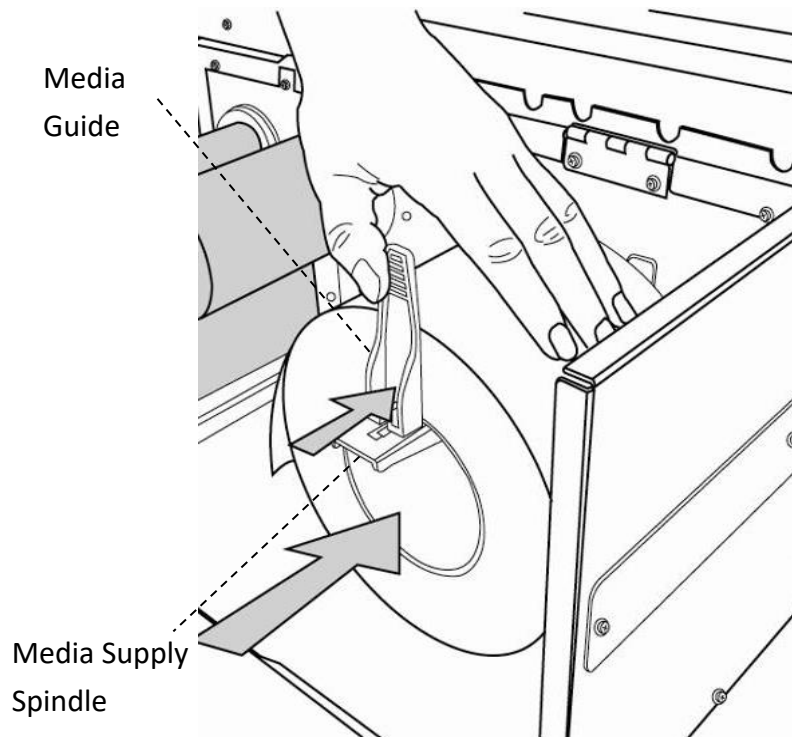

3. Rotate the head latch counterclockwise and open the outside media guide counterclockwise for media loading.

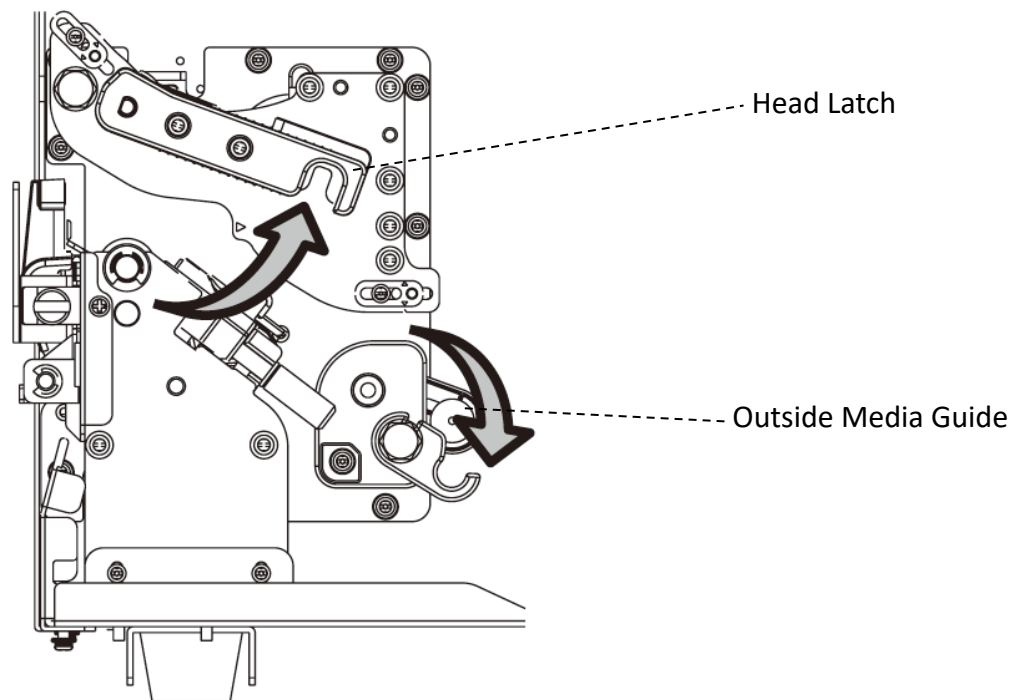

- The label must face up as the media passes through the printhead module.
Thread the media under the 'media guide' and through two rings until it locks in place at the 'Outside Media Guide'. Then, pass it under the paper sensor guide module and over the roller.

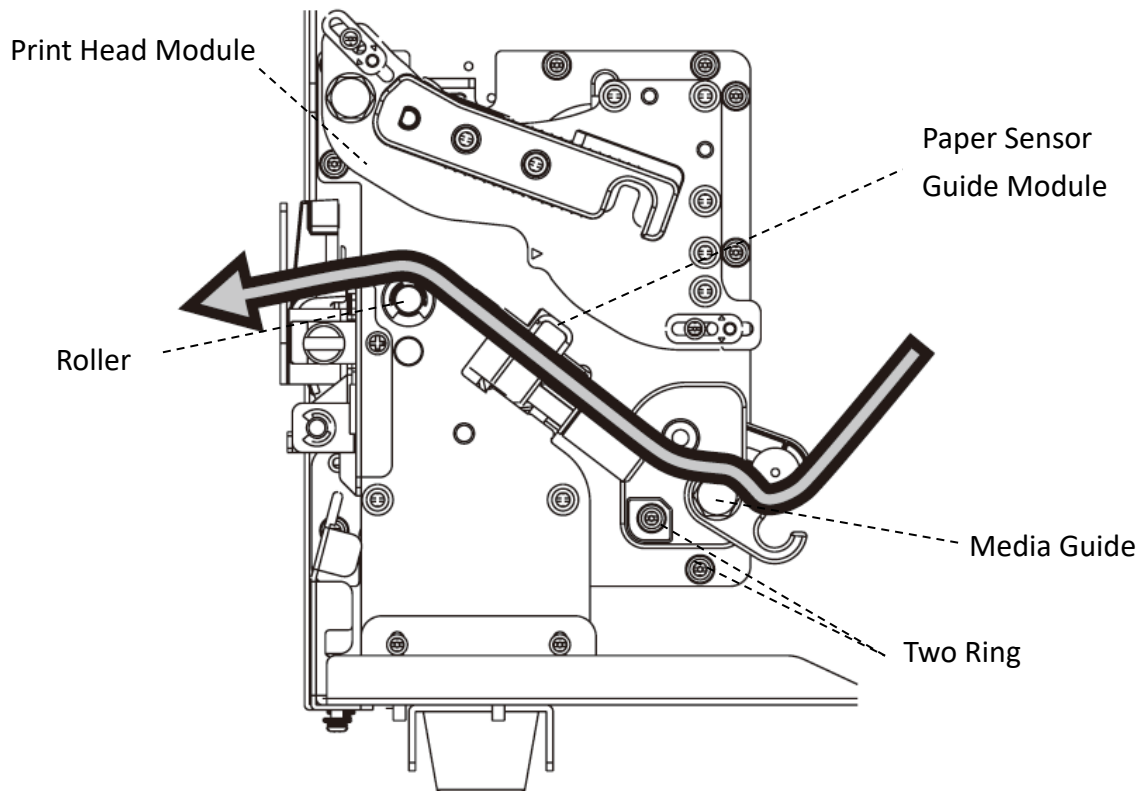

- Return the outside media guide and hook the head latch.

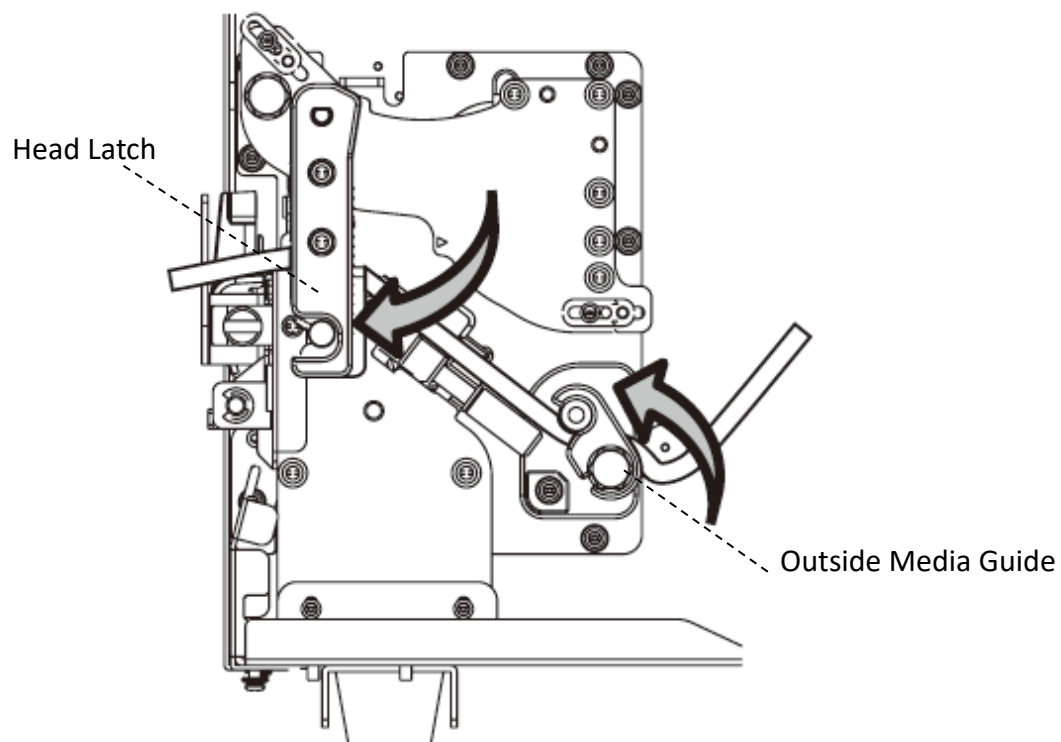

6. Close the top cover.

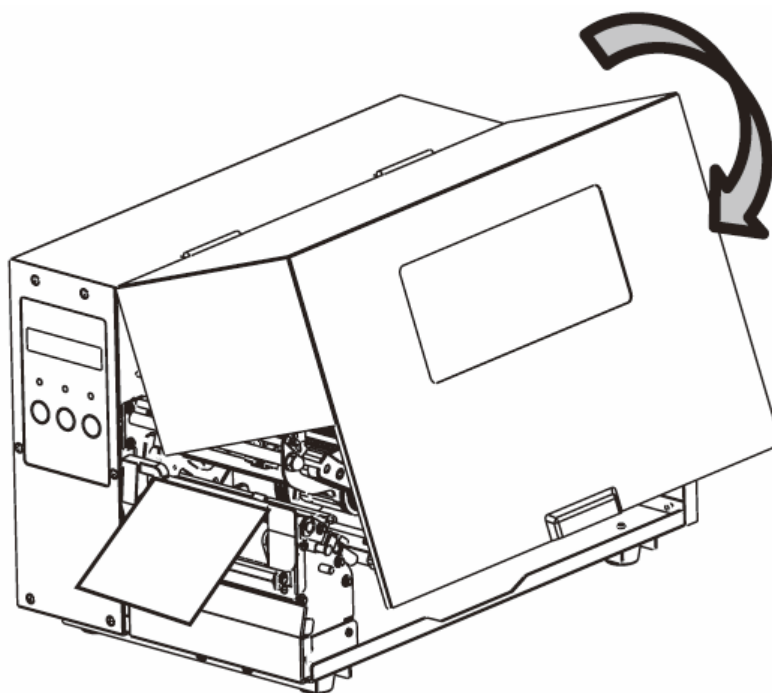

7. Press the FEED button if the printer is already on.

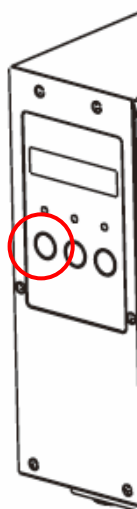

Note Make sure the label length of the die-cut media is at least 25 mm (1") or longer for direct thermal printing in tear-off mode with perforation.



Important After the media is loaded, please perform media calibration to calibrate the label sensor before printing.

Load Media in Peel-Off Mode

Steps 1 to 3 are the similar to “Standard Mode”.

1. Lift the top cover to expose the media compartment.
2. Load a roll of media into the media supply spindle and slide the media guide inward.
3. Rotate the head latch counterclockwise and open the outside media guide for media loading.
4. Remove enough labels from the leading end of the media roll to expose 6 inches of liner.

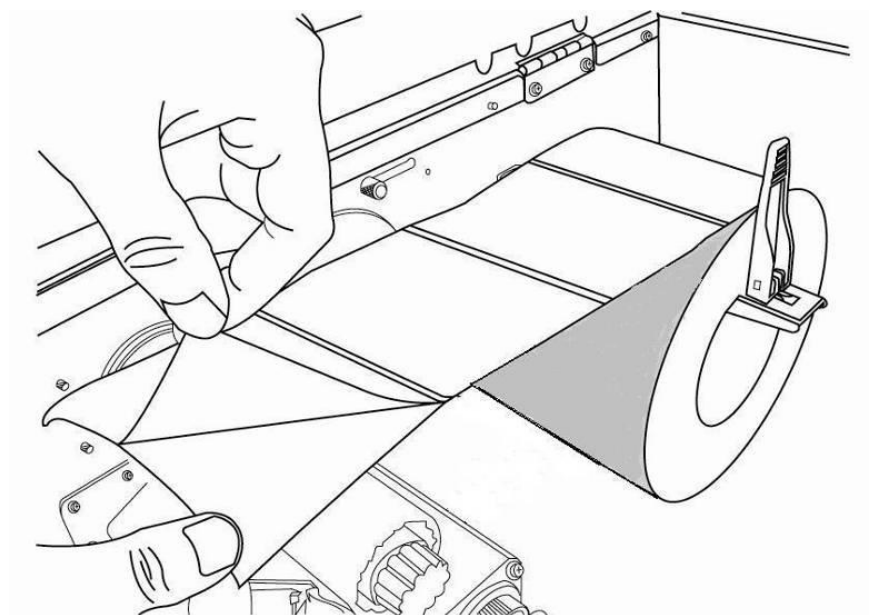

5. Guide the media liner under the printhead module. For more specific media guidance, refer to Step 4 in Standard Mode.

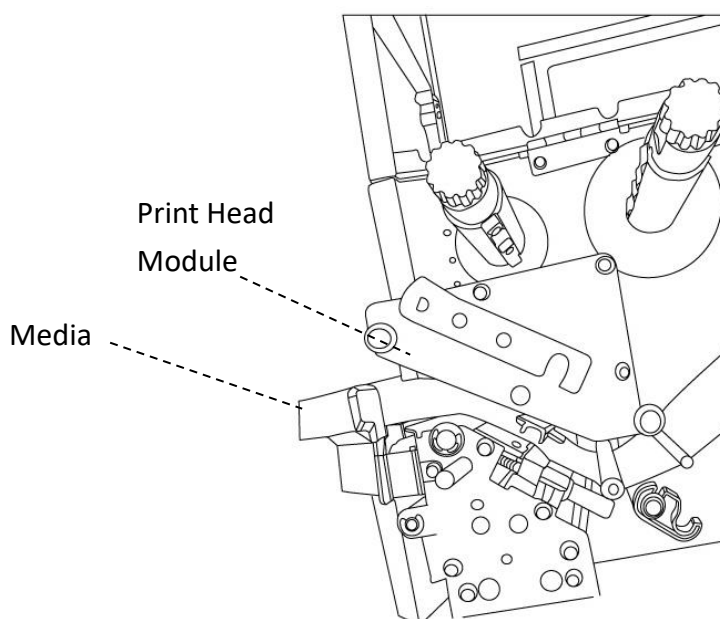

6. Push down the peel-off mechanism release lever and guide the media liner behind the dispenser (peeler) module.

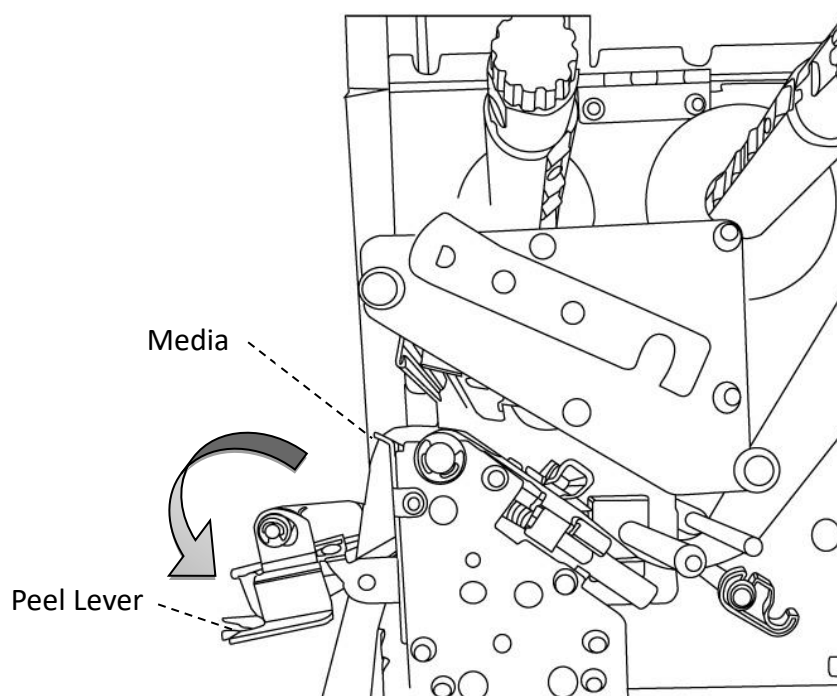

7. Close the dispenser (peeler) module using the peel-off mechanism release lever. Return the outside media guide and hook the head latch.

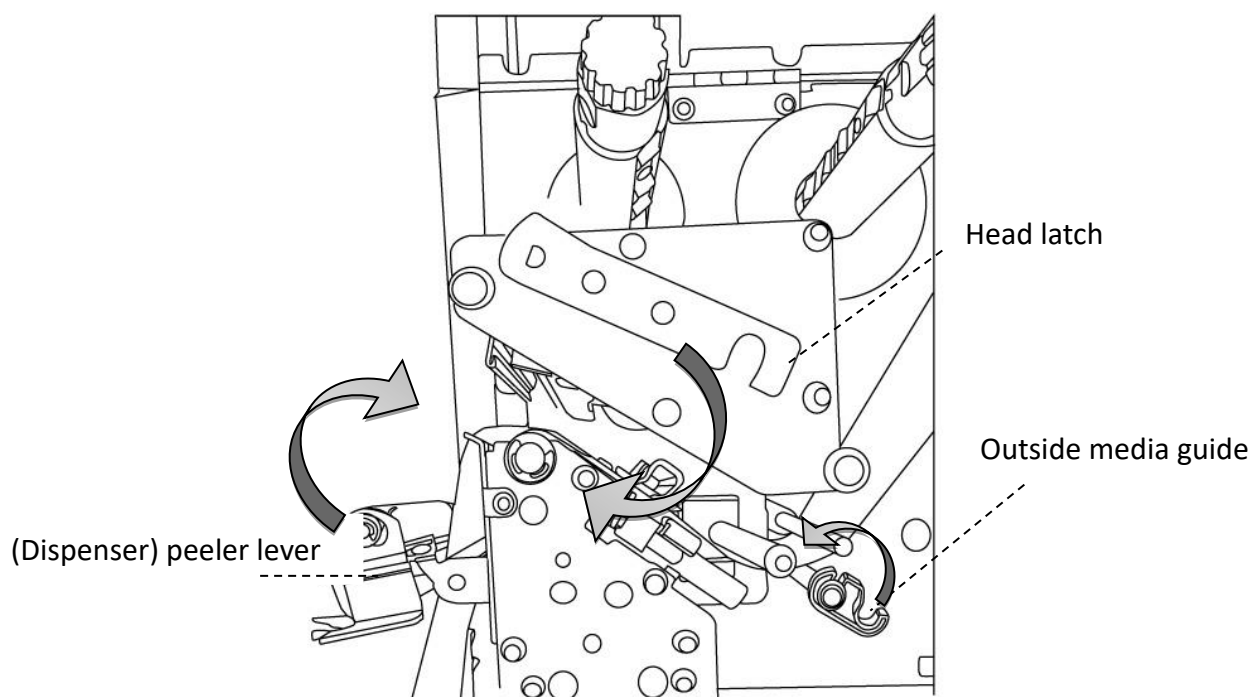

8. Close the top cover and turn on the printer or, press the FEED button if the printer is already on.

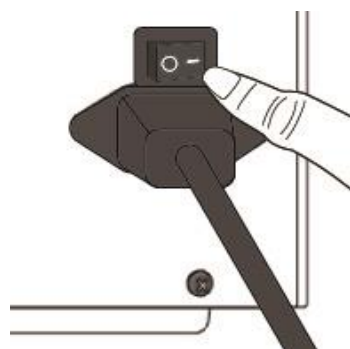

or

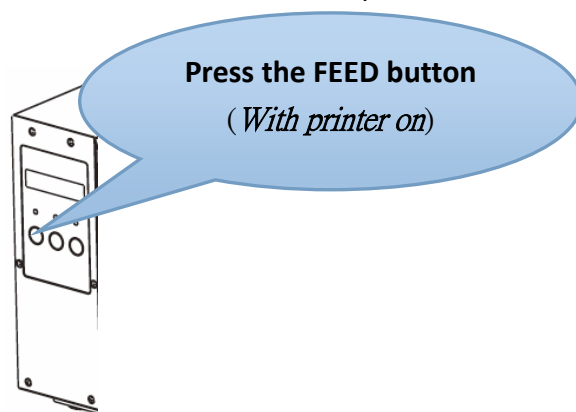

Important

After the media is loaded, please perform media calibration to calibrate the label sensor before printing.

Load Media in Rotary Cutter Mode

Steps 1 to 3 are the similar to “Standard Mode”.

1. Lift the top cover to expose the media compartment.
2. Load a roll of media into the media supply spindle and slide the media guide inward.
3. Rotate the head latch counterclockwise and turn on the outside media guide.
4. Load the media roll under the print head module and under the paper sensor guide over the roller. For more specific lead media, see Step 4 in Standard Mode.

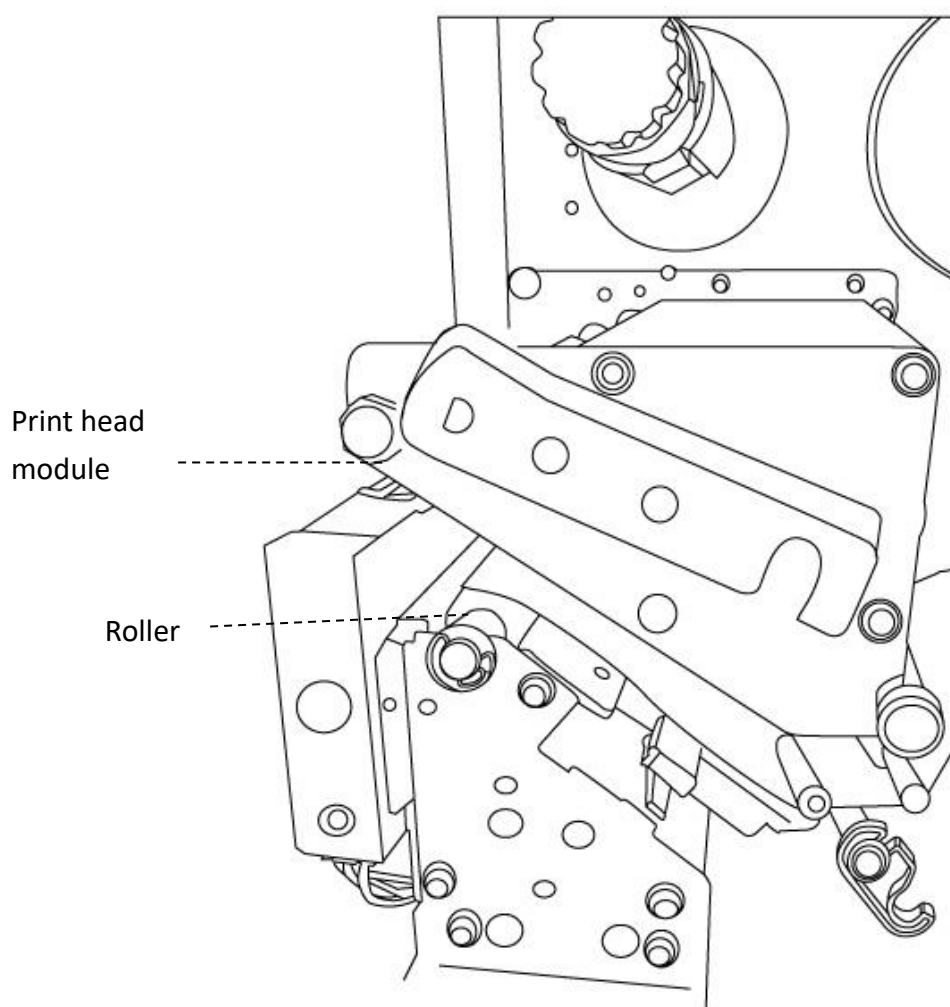

5. Return the outside media guide and hook the head latch.

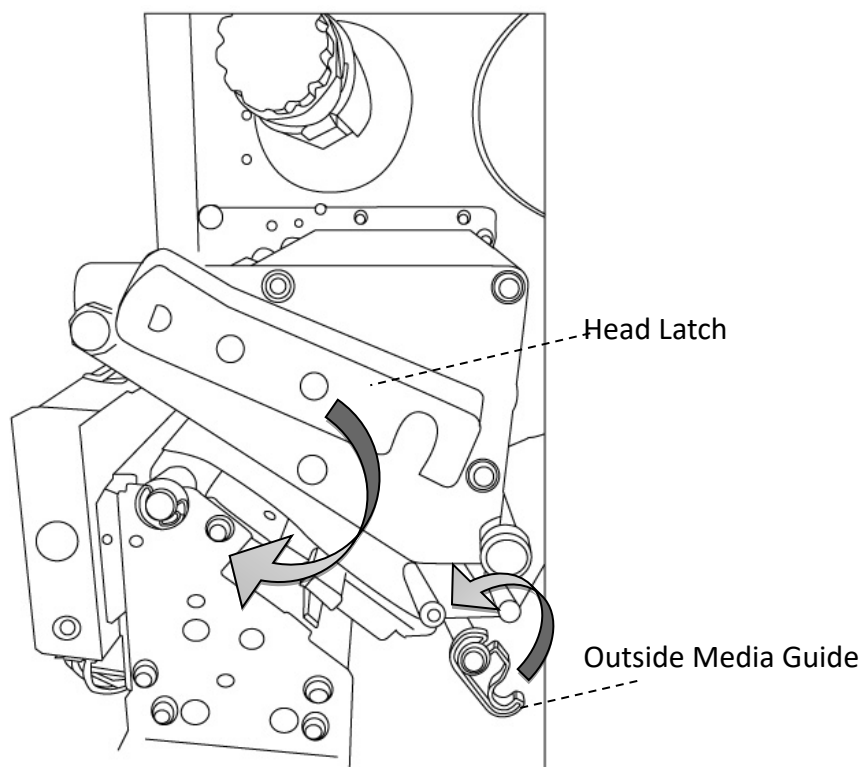

6. Close the top cover and turn on the printer or, press the FEED button if the printer is already on. The printer will then feed the labels through the cutter automatically.

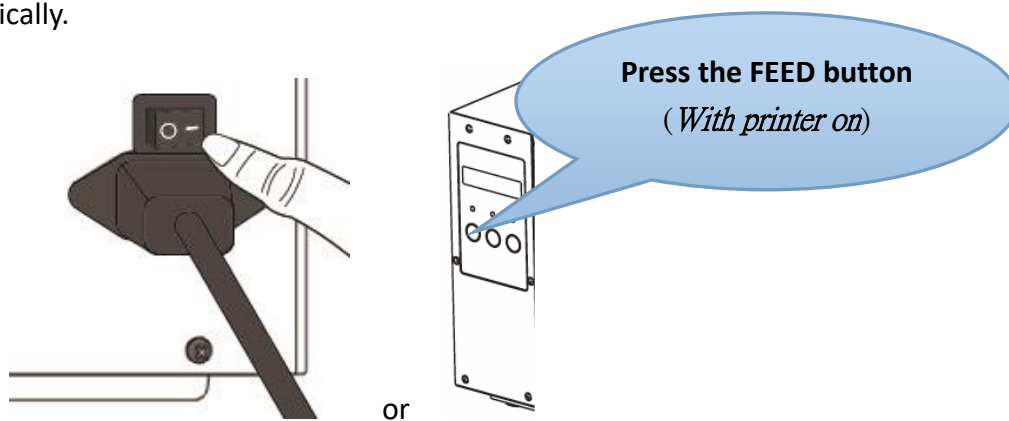

Important

After the media is loaded, please perform media calibration to calibrate the label sensor before printing.

Load Media In Guillotine Cutter Mode

Steps 1 to 3 are the similar to “Standard Mode”.

1. Lift the top cover to expose the media compartment.
2. Load a roll of media into the media supply spindle and slide the media guide inward.
3. Rotate the head latch counterclockwise and turn on the outside media guide.
4. Load the media roll into the printhead module and under the paper sensor guide. For more specific lead media, see Step 4 in Standard Mode. Unhook the cutter module and pull the down mechanism release lever from the cutter and feed media through the cutter.

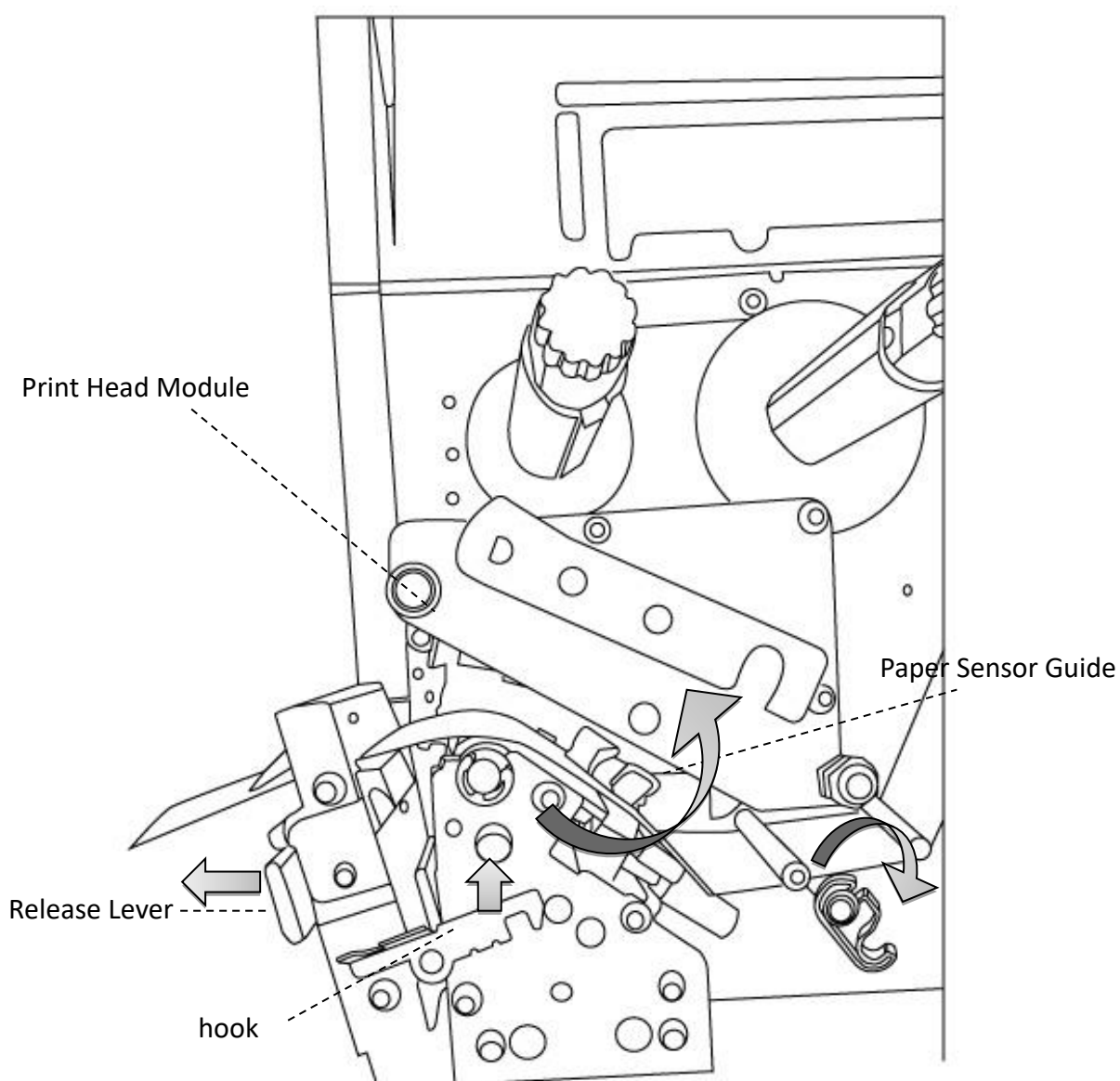

- Return the outside media guide and hook the head latch.

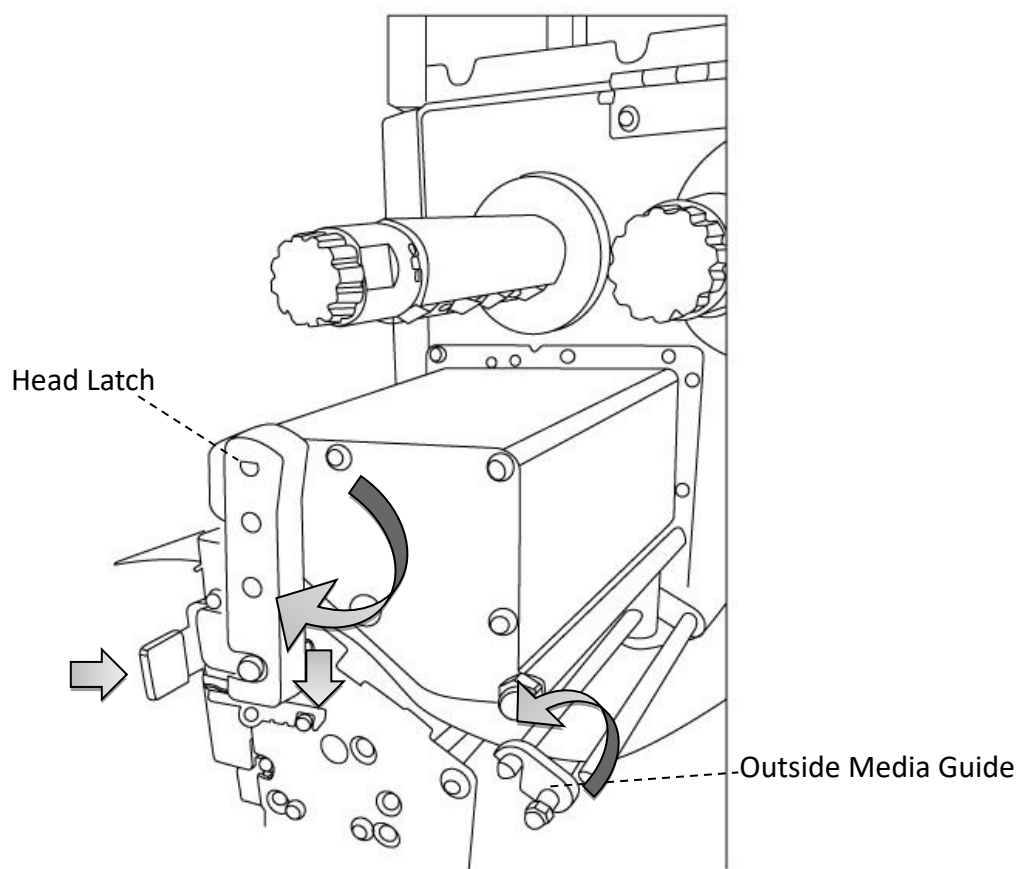

- Close the top cover and turn on the printer or, press the FEED button if the printer is already on. The printer will then feed the labels through the cutter automatically.

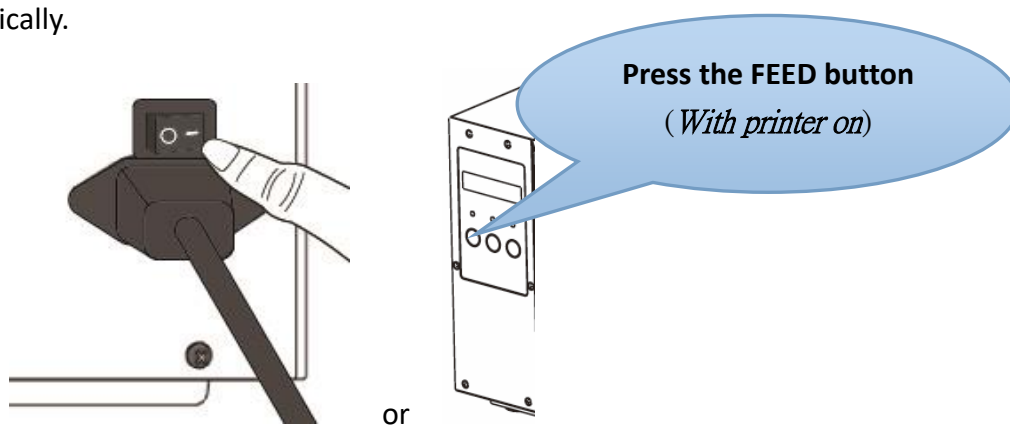



Important

After the media is loaded, please perform media calibration to calibrate the label sensor before printing.

2.3.3 Media types

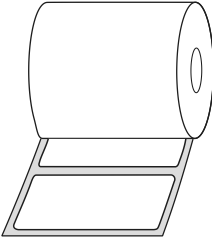
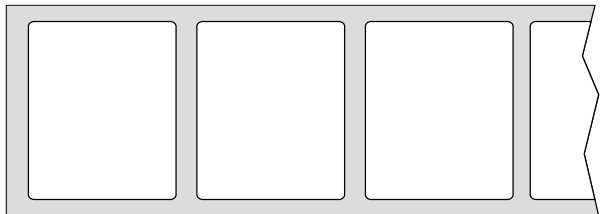
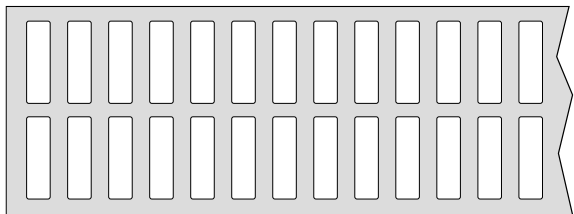
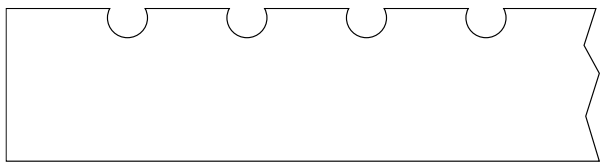
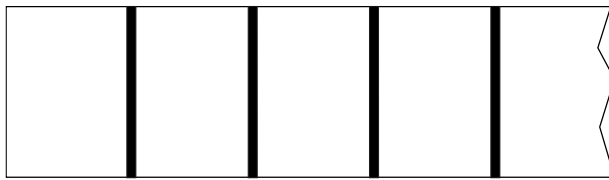
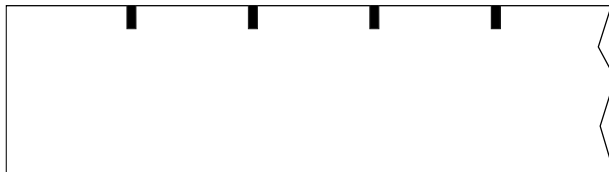
Your printer supports various media types, including non-continuous media, continuous media, and fanfold media. The following table provides details about them.

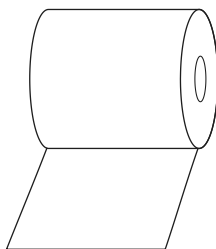
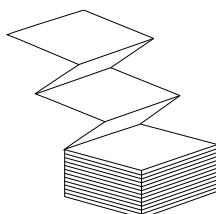
Media Type	Looks Like	Description
<p>Non-Continuous Media</p>	     	<p>Non-continuous media is the typical media for bar code printing. Labels and tags are made of various materials, such as paper, fabric or cardstock, and are separated by gaps, holes, notches or black marks. Many labels are self-adhesive with liners, while some are linerless.</p>

Media Type	Looks Like	Description
Continuous Media		Continuous media does not have gaps, holes, notches or black marks. It allows you to print data anywhere on the media. A cutter may be used for splitting labels. Mostly it is used for direct thermal printing.
Fanfold Media		Fanfold media is in continuous form, but it can be used as non-continuous media, because its labels are separated by folds. Some fanfold media also has black marks or liners.
Tag Media		Tag media is usually made from a heavy paper, with center hole to index. It does not have adhesive or a liner, and it is typically perforated between tags. The media may also have black marks or other separations.

2.4 Load Ribbon

The following steps only apply to thermal transfer printing mode.

Direct thermal does not need ribbon to be installed.

iX4-280/380 printer applies to both Inside wound ribbon and Outside wound ribbon.

The printer can switch automatically.



Note

- Media and ribbon types should be matched to provide with optimal print results.
- Always use ribbon that is wider than the media to protect the print head from wear.

2.4.1 Placing Ribbon Roll

- 1 Lift the top cover to expose the media compartment.

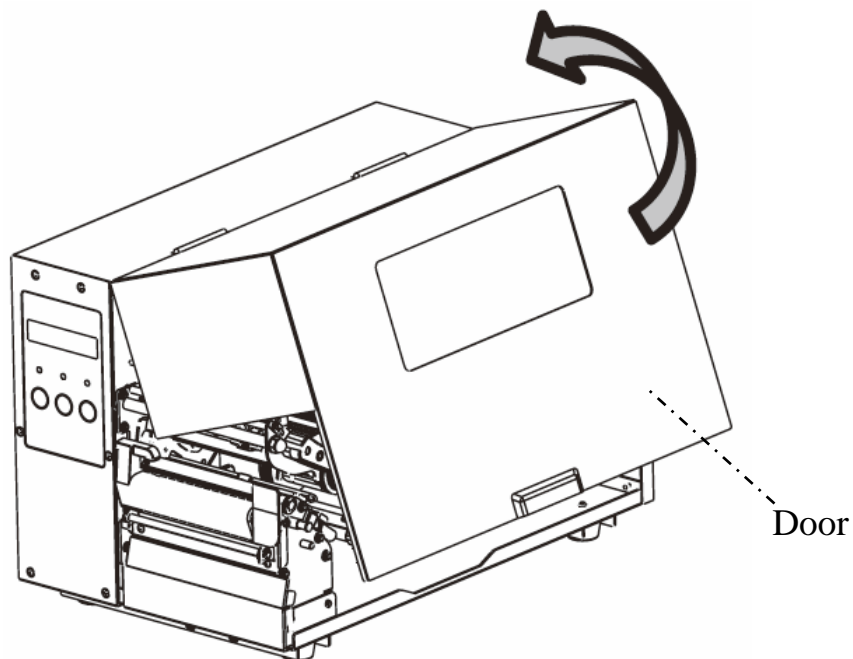

- 2 Rotate the head latch counterclockwise.

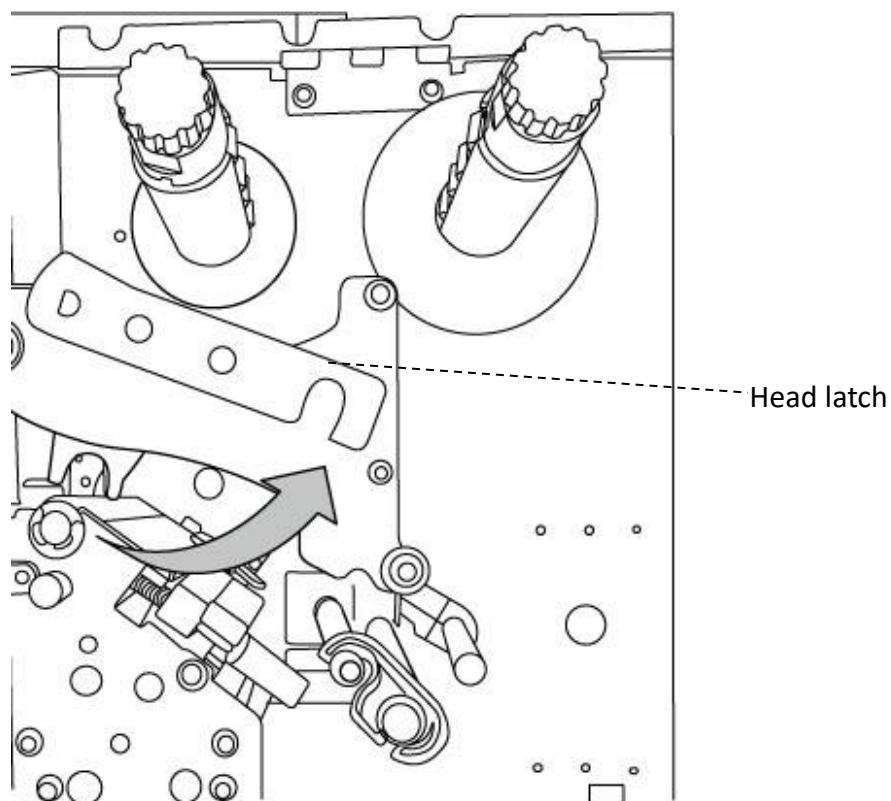

- 3 Unwrap the ribbon and separate the ribbon roll from the bare core. Load the ribbon roll onto the ribbon supply spindle.

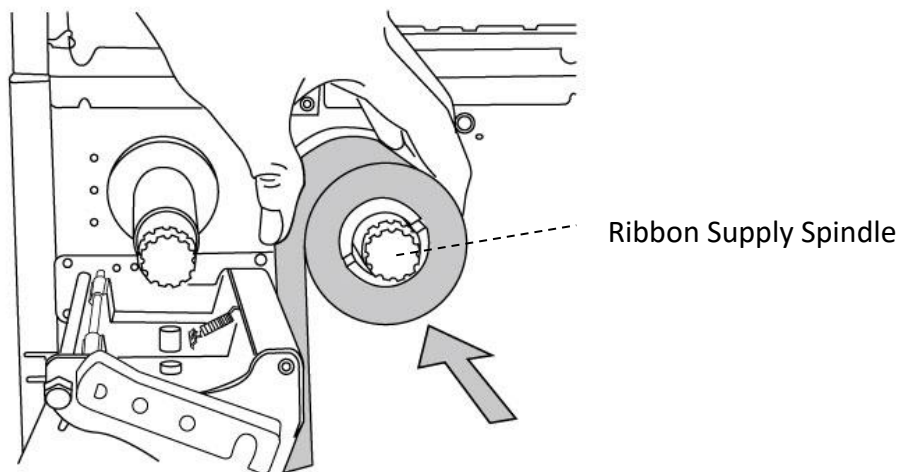

- 4 Thread the ribbon through the print head module. Place the edge of the ribbon on the bare core and wind a little onto the core. Make sure the coating side of the ribbon is facing down.

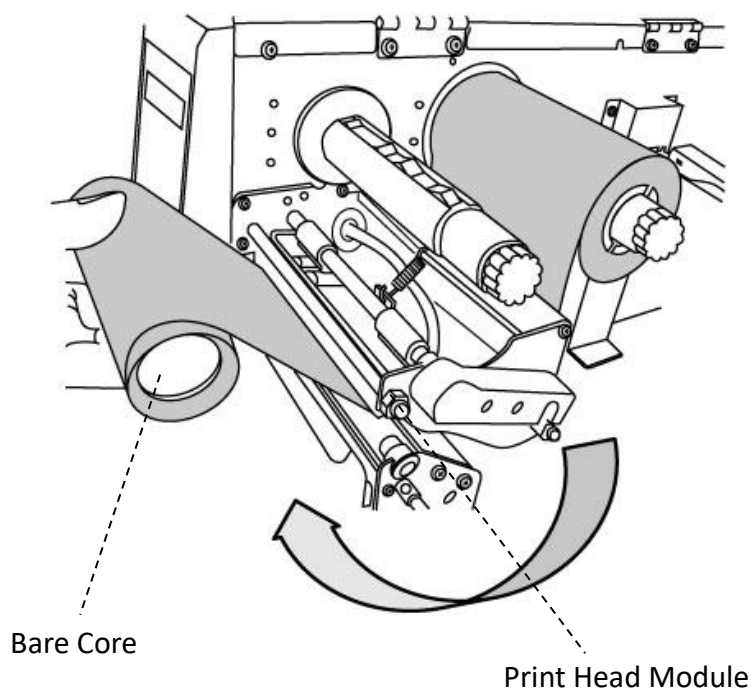

- 5 Slide the core onto the ribbon pick-up spindle. Rotate the spindle to ensure that the ribbon is wound tightly.

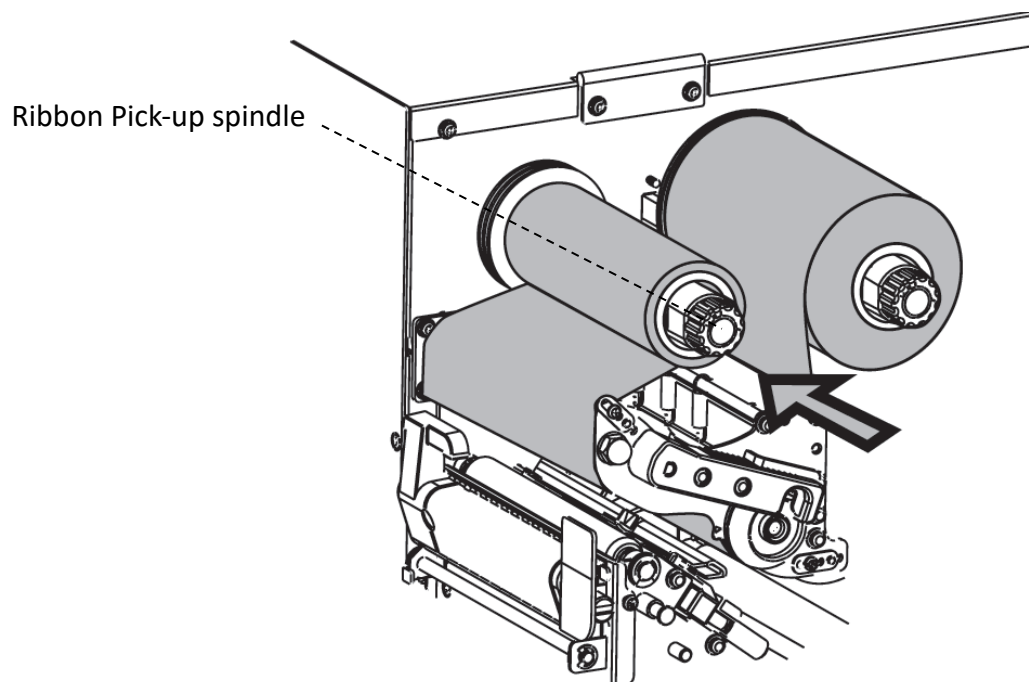

8. Close the top cover and turn on the printer.

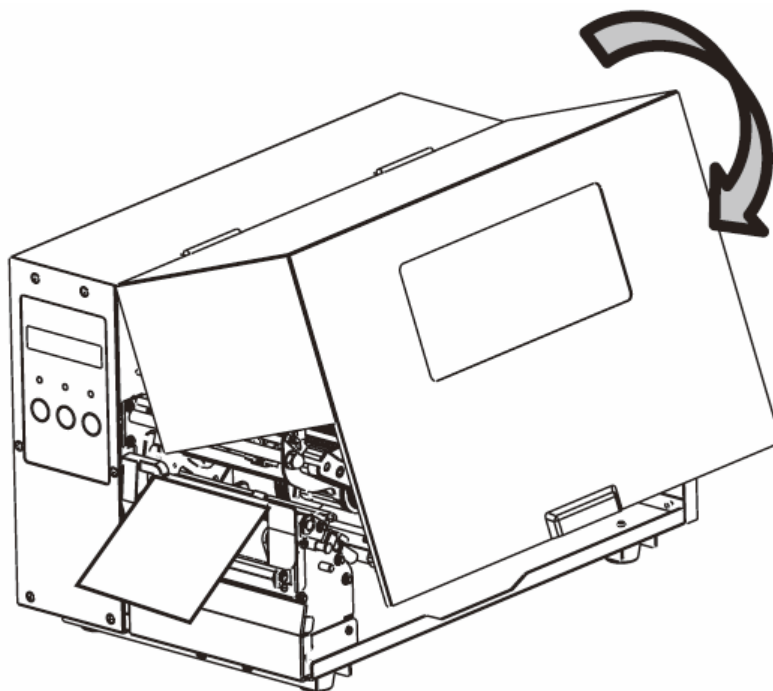

3 Printer operation

This chapter provides more specific information about printer operation.

3.1 Front Panel

Change settings using panel buttons:

Buttons	Function
PAUSE+CANCEL	Press to enter setting mode. Press again to exit setting mode and return to normal mode.
FEED	Press to show next parameter.
PAUSE	Press to show next setting item.
CANCEL	Select and save a parameter to permanent FLASH memory. Unless changed from the panel or by command, the parameter is saved even if the printer is restarted.



Warning *Do not change settings while printing or sending print data.*

3.1.1 LCD Function Setting Procedure

The following procedure is an example of setting procedure to direct thermal printing mode:

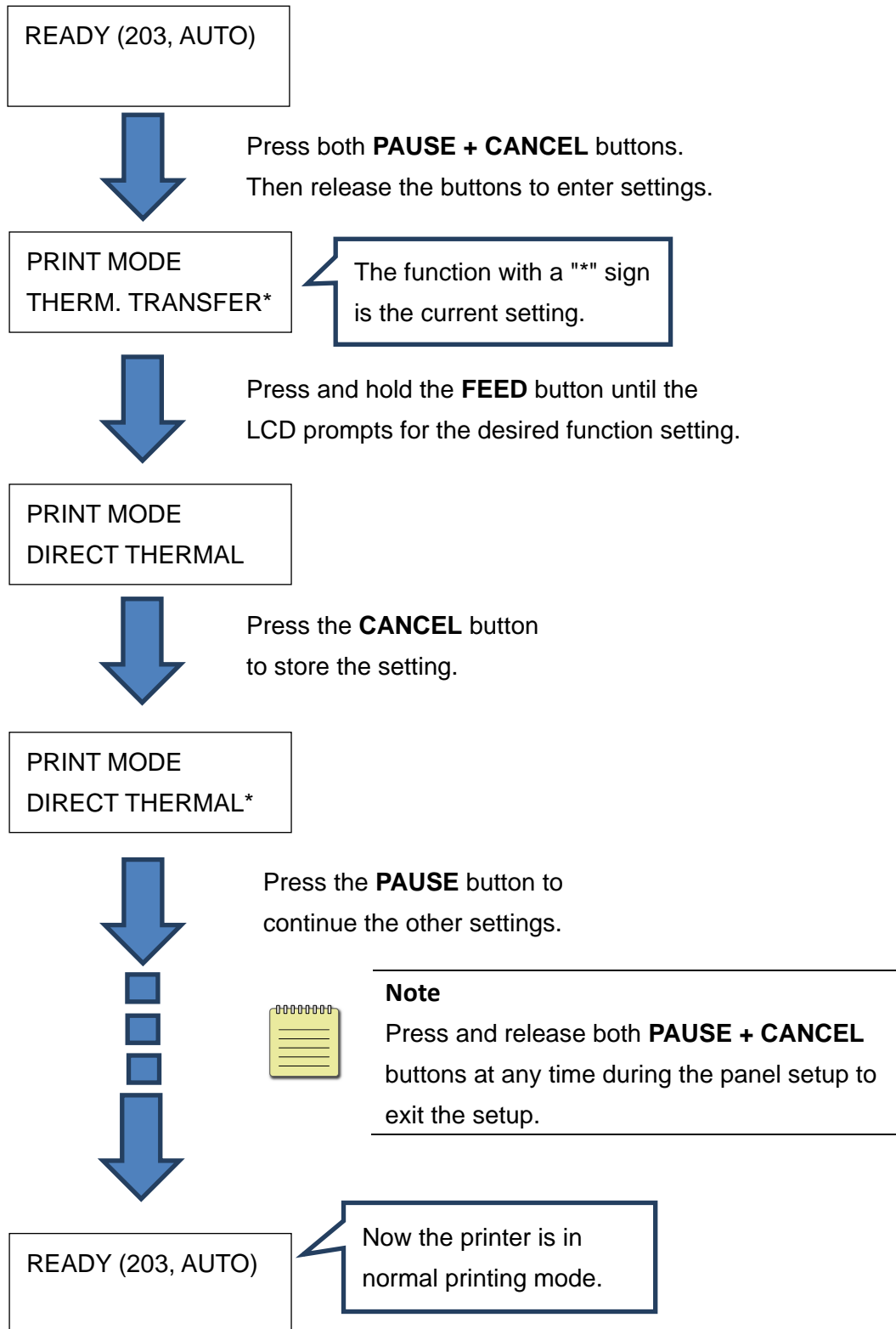

Press and hold **PAUSE + CANCEL** for 5 seconds to select different languages.

Item	Range	Factory Default
LANGUAGE	ENGLISH, FRENCH, GERMAN, ITALIAN, SPANISH, and PORTUGUESE.	ENGLISH

Press **PAUSE + CANCEL** less than 1 second to set printer function.

NO.	Item	Range	Factory Default	Remarks
1	PRINT MODE	THERM. TRANSFER DIRECT THERMAL	THERM. TRANSFER	(Restart printer after change setting)
2	CALIBRATION MODE	INTELLI PRINT SMART PRINT	INTELLI PRINT	INTELLI PRINT: Just install labels, latch print module, press FEED button once, and then the printer will feed 1-2 labels to detect next gap / black mark before printing. SMART PRINT: Print from the first label immediately according to label length setting. Make sure to carefully align label bottom edge at the tear-off position before printing. (Restart printer after change setting)
3	CONTROL CODE SET	STANDARD ALTERNATIVE ALTERNATIVE 2	1 STANDARD	Available only in PPLA printer language. (Restart printer after change setting)
4	CUT PEEL OFFSET	-015 ~ 015 mm	000 mm	To adjust cut and peel positions.
5	TPH VER OFFSET	-009~009 mm	000 mm	To adjust offset of vertical print position.
6	RECOVER PRINT	ENABLE, DISABLE	ENABLE	Will not reprint after recovering from media-out or ribbon-out errors.
7	CUTTER INSTALLED	NO YES	NO	(Restart printer after change setting)

8	PEELER	NO		
	INSTALLED	YES	NO	
9	STANDLONE	NO	NO	Available only in PPLB printer language.
	FORM FONT	YES		(Restart printer after change setting)
10	WIN. CON. LEN.	0 ~ 254 mm	000 mm	Available only in Windows with bundled printer driver and for continuous media.
11	SPEED	2 ~ 10 IPS	6 IPS	
		2 ~ 10 IPS (with peeler)	6 IPS (with peeler)	
12	COUNTING	DOWN	DOWN	
		UP		
13	MEDIASENSER TYPE	SEE-THROUGH	SEE-THROUGH	To select for different media types.
		REFLECTIVE		After changing sensor setting, make sure to calibrate before printing. (Restart printer after change setting)
14	BACK FEED	DISABLE	ENABLE	Available only in PPLA and PPLB printer languages.
		ENABLE		Once "ENABLE" is selected, printer enters BACK DISTANCE setting.
15	BACK DISTANCE	10~40 mm	22 mm	Available only when BACK FEED is enabled.
16	BASE DARKNESS	-28~28	0	
17	DARKNESS	0~30	16	To select darkness.
18	BAUD RATE	2400 / 4800 /	9600	Should be as same as setting of host. (Restart printer after change setting)
		9600 / 19200 /		
19	PARITY (RS232)	NONE	NONE	Should be as same as setting of host. (Restart printer after change setting)
		ODD		
		EVEN		

20	LENGTH (RS232)	8 DATA BITS	8 DATA BITS	Should be as same as setting of host. (Restart printer after change setting)
		7 DATA BITS		
21	CLEAR FLASH	NO	NO	When "YES" is selected, all the label forms, soft fonts, and graphics stored will be deleted. (Restart printer after change setting)
		YES		
22	SETTING PRIORITY	COMMAND/	COMMAND	Choosing priority of LCD settings. It decides which setting method - by command or by LCD panel, is prior.
		LCD PANEL		
23	EMULATION	AUTO	AUTO	(Restart printer after change setting)
		PPLA		
		PPLB		
		PPLZ		
24	BUZZER	DISABLE	ENABLE	
		ENABLE		
25	STANDBY	DISABLE	DISABLE	
		1 MINUTE		
		2 MINUTES		
		5 MINUTES		
		10 MINUTES		
		20 MINUTES		
		30 MINUTES		
26	LOAD DEFAULTS	LAST SAVED	LAST SAVED	LAST SAVED: NO.1~15, NO.17, NO.22, NO.24~25 and language will be loaded. FACTORY: NO.1, NO6, NO9, NO11, NO14~15, NO17, NO.27~30 will be loaded. NETWORK: NO.27~30 will be loaded. (Restart printer after change setting)
		FACTORY		
		NETWORK		

Ethernet settings and parameters

NO.	Item	Range	Factory Default	Remarks
27	DHCP	DISABLE ENABLE		<p>If printer has been connected to a router, IP address will be assigned automatically by DHCP server after power on.</p> <p>If printer is not connected to a router, with DHCP disabled, settings of IP ADDRESS, SUBNET MASK, and DEFAULT GATEWAY settings will be available on LCD.</p> <p>Every time when DISABLE is changed to be ENABLE, LCD will prompt "ETHERNET CARD UPDATE FINISH..."</p> <p>Then please reboot the printer.</p>
28	IP ADDRESS	<u>x</u> xx.x <u>x</u> x.x <u>x</u> x.x <u>x</u> x	xxx range:0~255	<p>When DHCP is disabled, default IP address is 192.168.1.100.</p> <p>If " _ " sign appears, that means that DHCP setting is disabled. On the contrary, DHCP setting is enabled.</p> <p>1. <u>FEED/CONFIG</u> : change contents. (ex. from 000.000.000.000 to 255.255.255.255)</p> <p>2. <u>PAUSE/CALIBR</u> : shift " _ " sign position. (ex. from <u>255.255.255.255</u> to 255.255.255.255)</p> <p>3. <u>CANCEL/RESET</u> : Select next function setting. (" _ " sign must at the third digit of each parameter, for example, <u>xxx</u>).</p> <p>4. To change IP ADDRESS or SUBNET MASK, enter DEFAULT GATEWAY setting, press CANCEL button once; LCD will prompt "ETHERNET CARD UPDATE FINISH..."</p> <p>Then reboot the printer.</p> <p>To have more information on Ethernet settings, please refer to Ethernet User's Guide.</p>
29	SUBNET MASK	<u>x</u> xx.x <u>x</u> x.x <u>x</u> x.x <u>x</u> x		
30	DEFAULT GATEWAY	<u>x</u> xx.x <u>x</u> x.x <u>x</u> x.x <u>x</u> x		
31	MAC ADDRESS	Read only		

WiFi module (Optional)

Item	Range	Remarks
WIFI SSID	Read only	WIFI module is an option for iX4-280/380. Connect printer to PC and use print tool to set WIFI module. To have more information, please refer to Print Tool user guide.
WIFI IP ADDRESS	Read only	
WIFI SUBNET MASK	Read only	
WIFI GATEWAY	Read only	
WIFI MAC ADDRESS	Read only	

3.2 Printing Media Calibration & Configuration

Before calibration, be sure media and ribbon (for thermal transfer printing) have been loaded correctly. The label sensor needs to locate properly to index labels' gaps/ notches/ holes. After the media is loaded, please perform media calibration to calibrate the label sensor in advance. For non-LCD printers, see Indicators.

1. Turn off the printer.
2. Press and hold the **PAUSE** button and turn on the power.
3. When "CALIBRATION ..." is displayed on the LCD, and both READY and MEDIA indicators blink, release the **PAUSE** button.
4. The printer feeds 1 or 2 blank labels.
5. When "READY" is displayed, the READY and MEDIA indicators stop blinking but remain illuminated.

3.3 Printing a Configuration Report

Perform a self-test and print a configuration report to check the printer's print quality and internal settings. Follow the steps below:

1. Turn off the printer.
2. Load media and ribbon.
3. Press and hold the **FEED** button while turning on the power.
4. When "SELF-TEST ..." is displayed on the LCD, release the **FEED** button.
5. The printer will now print a configuration report, as shown in the example on the next page. All characters will be printed in 2 columns: the right shows characters received from your system, and the left are the corresponding hexadecimal values of the characters. It allows users or engineers to verify and debug the program.

For non-LCD printers, see Indicators.

After printing the self-test page, you can view the printer's configuration settings. The self-test page provides valuable information about the printer's current setup, allowing you to verify and ensure that the printer is functioning correctly and set up to meet your specific needs. The printed settings typically include details as follows:

1. iX4-280-VXX.XX XXXXXXX PPLX

The firmware version and its build date

2. Standard RAM

Total SDRAM size

3. Available RAM

RAM is able to be used.

4. Flash Type

The flash memory type and size

5. Available Flash

Flash is able to be used.

6. No of DL soft fonts (FLASH)

The number of fonts is downloaded in Flash.

7. No of DL soft fonts (RAM)

The number of fonts is downloaded in RAM.

8. No of DL soft fonts (HOST)

The number of fonts is downloaded in USB HOST.

9. H. Position Adjust

Move the print position horizontally.

10. Sensor Type

The media sensor type, such as reflective sensor or see-thru sensor

11. REF: XXXX SEE: XXXX

The two reference values in the self-test page of the barcode printer represents calibration values. Typically, these reference values are meant for use by technical support or maintenance personnel to ascertain the specific configuration or calibration status of the printer.

12. RTC Time

The date and time of the real-time clock (RTC). The default format is month/day/year (hour:minute:second). If your printer has a built-in RTC, the RTC time shows here.

13. Max Label Height

The max label length you can print at a time. For 200 dpi models, it is 100 inches; for 300 dpi models, it is 50 inches.

14. Print Width

The print width in dots

15. Lab Len (Top to Top)

For non-continuous media, it is the length between the tops of two labels.

16. Speed

The speed of printing. The unit is inch per second (ips).

17. Darkness

The current darkness.

18. Print Method

It is either thermal transfer (TT) or direct thermal (DT) printing. TT requires ribbons and DT doesn't.

19. Print Length

The total print length.

20. Cut Count

It counts the times the cutter cuts.

21. RS232 Protocol

It lists RS-232C settings in the following order: baud rate, data length, parity check, stop bit and flow control.

22. Code page

The character set table.

23. Media

The media type in use.

24. Calibration mode

There are intelli mode or smart mode.

Intelli mode: Just install labels, latch print module, press FEED button once, and then the printer will feed 1-2 labels to detect next gap / black mark before printing. The printer will feed 1-2 labels automatically before printing, if FEED button is not pressed.

Smart mode: Print from the first label immediately according to label length setting. Make sure to carefully align label bottom edge at the tear-off position before printing.

25. Backfeed Enabled/Disabled

Enable or disable backfeed during the printing process. When it is enabled, the printer moves the paper forward in a predefined length 1 second after printing, and pulls the paper back in a predefined length once the printing begins again. When it is disabled, the printer won't move the paper at all.

26. Cutter Enabled/Disabled

Enable or disable the cutter during the printing process.

27. Peeler Enabled/Disabled

Enable or disable the dispenser (peeler) during the printing process.

28. Cutter/Peeler Offset

Move the cutting line or the peeling position forward or backward. The value in the angle brackets is the offset unit.

29. IP Address

The static IP address of the printer. The default value is "192.168.1.1".

30. Subnet Mask

The manually specified subnet mask of the printer. The default value is "255.255.255.0."

31. Gateway

The manually specified gateway of the printer. The default value is "0.0.0.0."

32. MAC Address

The unique address assigned to the printer that connects to the internet.

33. DHCP

When DHCP is enabled, it assigns an IP address to the printer automatically.

34. DHCP Client ID

It is an arbitrary value sent to the DHCP server to reserve an IP address for the printer.

35. DHCP Host Name

The name of a DHCP client.

36. SNMP

When it is enabled, the host gets or sets parameters registered as SNMP entities.

37. Socket Communication

When it is enabled, the host communicates with the printer via the socket.

38. Socket Port

The socket number of the printer.

39. IPv6 Mode

It determines how you get the IPv6 address of your printer. There are three modes: MANUAL, DHCPv6 or AUTO.

40. IPv6 Type

It is the IPv6 address type of your printer. There are four types: NONE, NORMAL, EUI and ANY.

41. IPv6 Address

The static IPv6 address of your printer.

42. Link Local

The IPv6 address that used in a network segment. It is allocated automatically.

43. Product SN

The serial number of product.

44. USB SN

The Serial number of USB host.

45. CG Enable

Printer is able to use True Type font.

46. See-Through Sensor Offset

For developers to debug.

Note:

The patterns displayed in items 45 to 52 are as shown in the schematic below:

```
ot(0,0)<0.1dot,0.01mm>  
rm(0,0)<1+ 0-,0.01mm>  
sm(0,0)<1+ 0-,0.01mm>  
rv(241,136,104)<0.01v><P>  
sv(265,158,106)<0.01v><P>  
bv(329,6,322)<0.01v><P>  
rso(0)<0.01mm>  
sso(0)<0.01mm>  
ragc(202)<0.01v><P> 1v(3)  
sagc(156)<0.01v><P> 1v(4)  
TPL: 0
```

47. Font Image

You can use them as the reference to check your label font.

Note:

The patterns displayed in items 45 to 52 are as shown in the schematic below:

```
This is internal font 1. 0123456789 ABCabcXyz  
This is internal font 2. 0123456789 ABCabcXyz  
This is internal font 3. 0123456789 ABCabcXyz  
This is internal font 4. 0123456789 ABCXYZ  
THIS IS INTERNAL FONT
```

48. TPH Test Pattern

You can use them to check broken pins on the printhead.

Note:

The patterns displayed in items 45 to 52 are as shown in the schematic below:

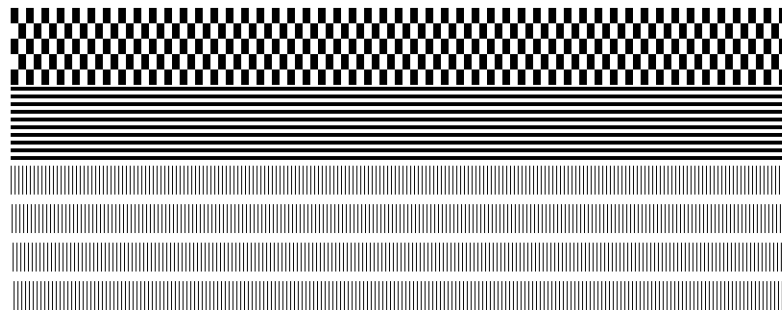

If your printer has a Wi-Fi module, your PPLB configuration label will contain the following entries:

```
WLAN FW VERSION: 1.00 _____ 1  
DATE: 2015.05.26 _____ 2  
WLAN IP ADDRESS: 0.0.0.0 _____ 3  
WLAN SUBNET MASK: 0.0.0.0 _____ 4  
WLAN GATEWAY: 0.0.0.0 _____ 5  
WLAN MAC ADDRESS: 00-80-92-4F-77-35 _____ 6  
WLAN DHCP: AUTO _____ 7  
WLAN DHCP HOSTNAME: 00-80-92-4F-77-3 _____ 8  
: 5  
WLAN SOCKET PORT: 9100 _____ 9  
WLAN SSID: WIRELESS PRINTER _____ 10  
WLAN MODE: Infrastructure _____ 11  
WLAN COUNTRY CODE: USA _____ 12  
WLAN CHANNEL: AUTO _____ 13  
WLAN NETWORK AUTHENTICATION: Open _____ 14  
WLAN WEP: OFF _____ 15
```

1. FW Version

WLAN board firmware version.

2. Date

WLAN board firmware version date.

3. IP Address

The IP address of your printer. When DHCP is enabled, it shows the automatically assigned IP address; when DHCP is disabled, it shows the manually specified IP address.

4. Subnet mask

The netmask of your printer. When DHCP is enabled, it shows the automatically assigned netmask; when DHCP is disabled, it shows the manually specified netmask.

5. Gateway

The gateway of your printer. When DHCP is enabled, it shows the automatically assigned gateway; when DHCP is disabled, it shows the manually specified gateway.

6. Mac address

The unique address assigned to your printer that connects to the internet.

7. DHCP

When DHCP is enabled, it assigns an IP address to your printer automatically.

8. DHCP Hostname

The name of a DHCP client.

9. Socket Port

The socket number of the printer.

10. SSID

Short for service set identifier. It is the name of a wireless local area network.

11. Mode

There are ad-hoc and infrastructure mode. Refer to Print Tool Network type description from Technical manual.

12. Country Code

The country or region.

13. Channel

The Wi-Fi channel.

14. Network Authentication

There are six mode. Refer to Printer Tool Network authentication description from Technical manual.

15. WEP

Refer to Printer Tool Wep description from Technical manual.

3.4 Restore to Factory Default

Be cautioned that this will reset all printer settings back to defaults; if possible, print the configuration label in advance before reset. All settings stored in FLASH memory are retained even after turning off the printer. Printer mode without LCD can see indicators.

To reset the printer to factory default settings:

1. Turn off the printer.
2. Press and hold the **CANCEL** button and turn on the printer.
3. When "RESET ..." is displayed on the LCD and the READY indicator blinks, release the **CANCEL** button.
4. When "READY" is displayed on the LCD, the READY indicator stops blinking but remains illuminated.
5. The following information is now back to defaults:
 - Label parameters
 - Heat (Darkness)
 - Speed
 - Others for specific emulation



Note:

Print length meter which indicates label length already printed cannot be reset.

3.5 Media sensing

The printer offers two types of media sensors: transmissive sensor and reflective one. They are used for detecting specific media types. Both sensor types are installed together as a movable module.

3.5.1 Transmissive sensor

The transmissive sensor is used for detecting gaps across the entire width of the label.

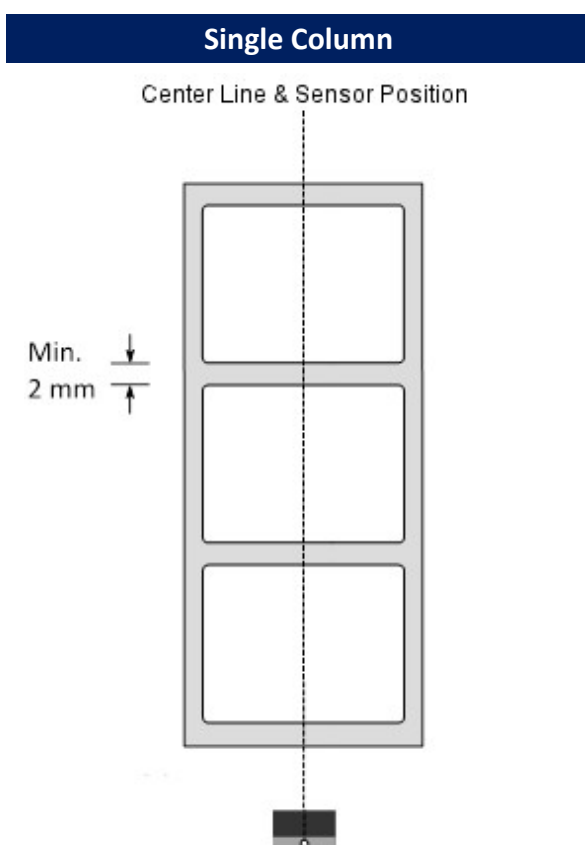

3.5.2 Reflective sensor

The reflective sensor detects gaps, notches and black marks.

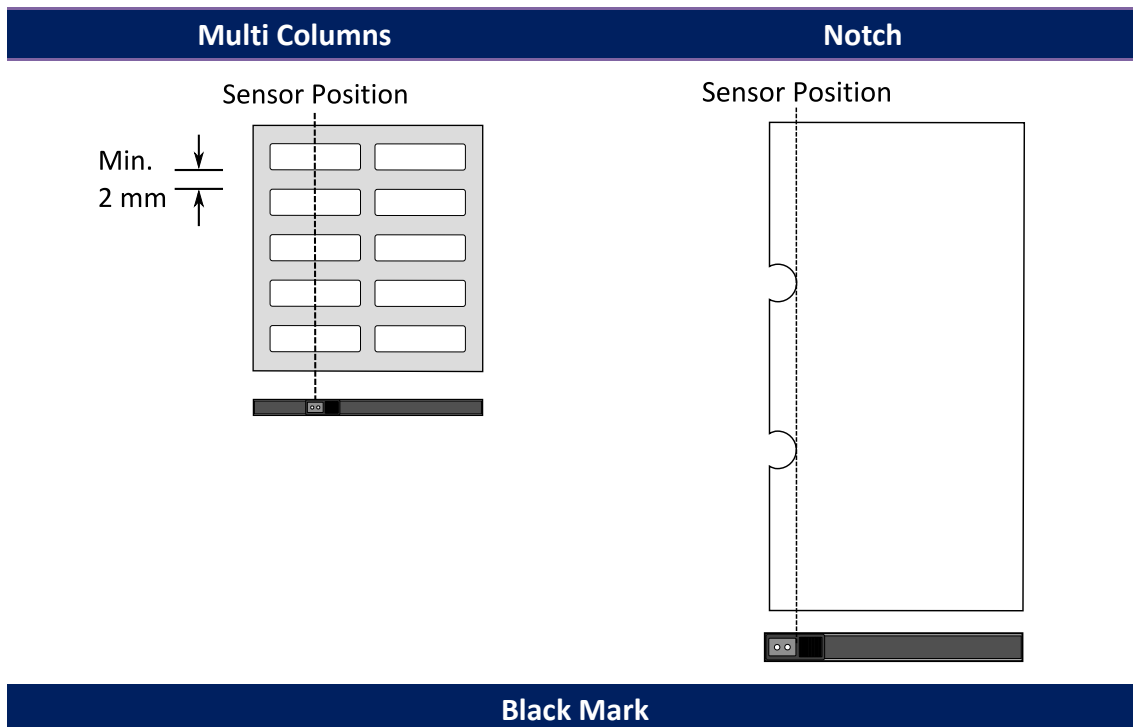

Black Mark

Flip the media so the black-mark side is facing down to align with the sensor.

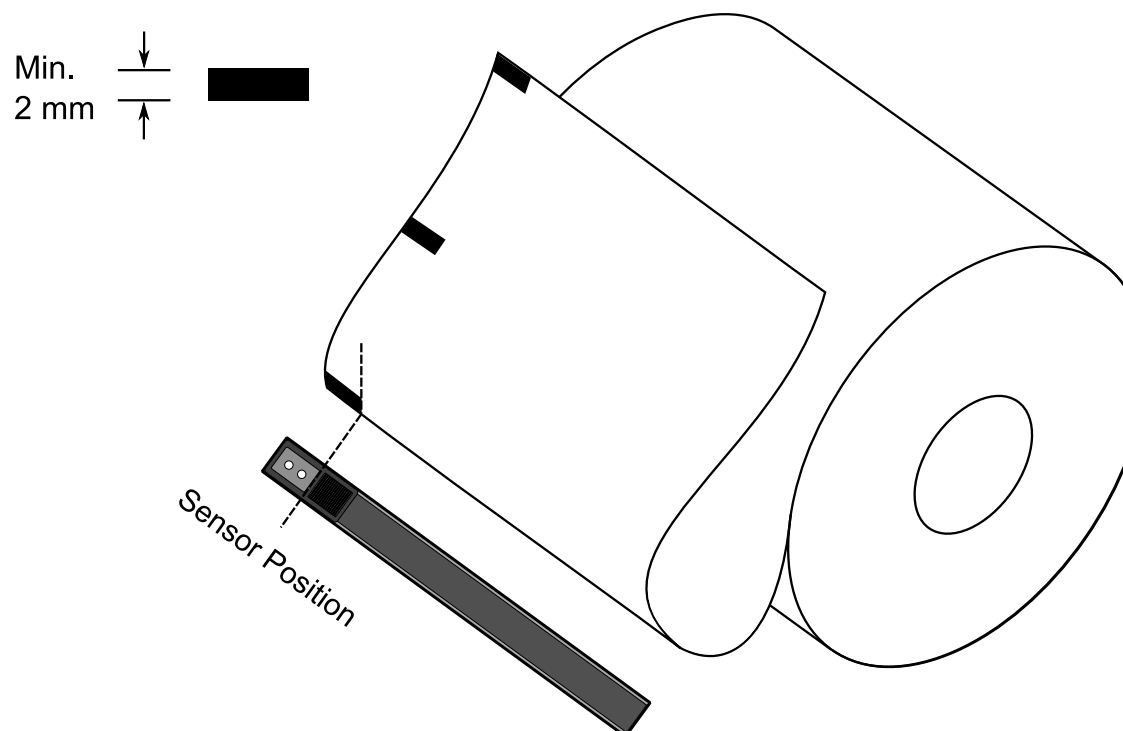

3.5.3 Adjust Position of Label Sensor

Function of the label sensor is to detect the gap, notch, or holes of labels, to help the printer for accurate print positions and label length. For labels with gaps, label sensor can be positioned wherever media locates. If labels with notches or holes are in use, pull in or out Paper Sensor Position Lever, to horizontally adjust position of label sensor.

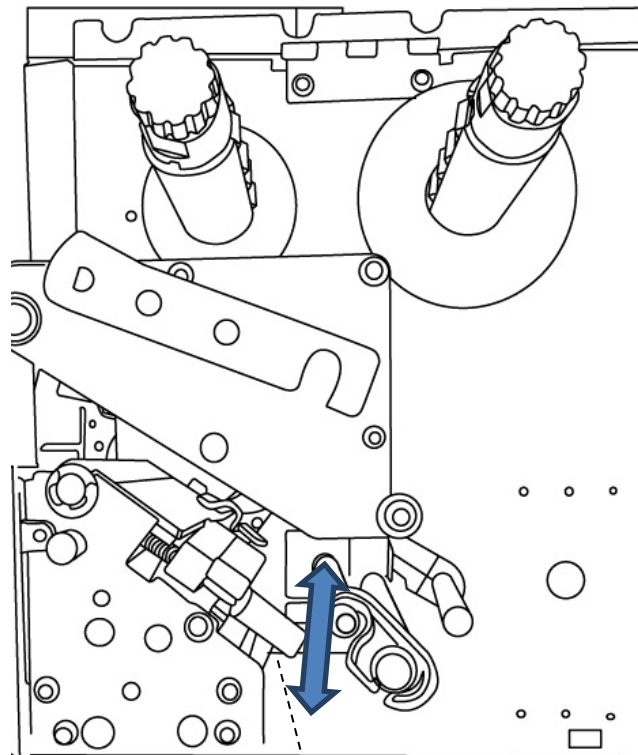

Paper Sensor Position Lever

- Make sure the Media sensor position mark locates right on notch or hole of labels. Check below.

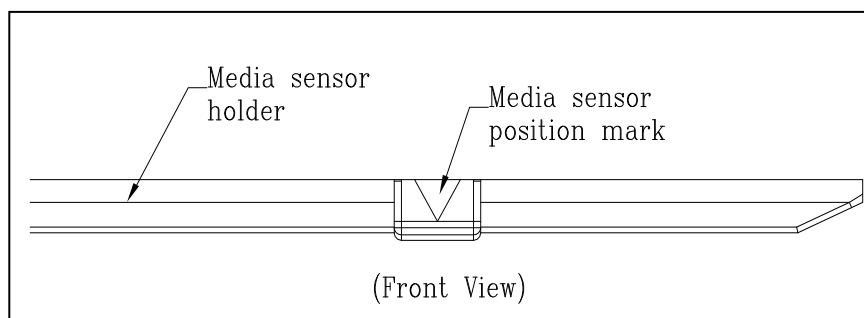

3.6 Communications

3.6.1 Interfaces and Requirements

This printer comes with USB type A and type B interface, a nine-pin Electronics Industries Association (EIA) RS-232 serial data interface, and a GPIO interface (optional).

■ USB Interface Requirements

The Universal Serial Bus (USB) interface is compatible with your existing PC hardware. The USB's "plug and play" design makes installation easy. Multiple printers can share a single USB port/hub. The different usage of type A and B as below.

USB type A	USB flash drive, USB keyboard, or USB scanner
USB type B	To connect the printer to a PC for initial setup and configuration

■ Serial (RS-232) Port

The required cable must have a nine-pin "D" type male connector on one end, which is plugged into serial port located on the back of the printer. The other end of the cable connects to a serial port on the host computer. For technical and pin-out information, please refer to RS-232C in this manual.

■ General-purpose input/output (GPIO)

The pins depend on the application and the signal is user selectable. The function is diversity. For general-purpose I/O, signals programmed as inputs can cause CPU to interrupt. For more information, contact your local dealer.

■ Ethernet Module Status Indicators

The indicators with two different colors help users understand the status of Ethernet:

LED Status	Description	
Both Off	No Ethernet link detected.	
Blinking	The printer waits for printer ready. It will take about few seconds to be ready.	
Orange (Yellow)	Duplex / COL LED	On: Full duplex Off: Half duplex Blinking: Collision occurs
Green	Link / Activity LED	On: link up Off: link down Blinking: activity

3.7 Driver installation

The printer driver is compatible with Windows Vista/7/8/10, Linux, macOS, and Raspberry Pi. You can use it to print to any popular software application, including Argox Bartender UL label editing software or MS Word, etc., on these operating systems.

Drivers can be downloaded from Argox website: <https://www.argo.com/>.

3.7.1 Installing a Plug and Play printer driver (for USB only)



Note:

We strongly recommend that you use the Seagull Driver Wizard instead of the Microsoft Windows Add Printer Wizard when installing and updating your Drivers by Seagull.

(Even though the "Add Printer Wizard" is from Microsoft, it too easily performs a number of tasks incorrectly when updating existing drivers. It also badly handles the situation where a printer driver is already in use by a Windows application.)

1. Turn off the printer. Plug the power cable into the power socket on the wall, and then connect the other end of the cable to printer's power socket. Connect the USB cable to the USB port on the printer and on the PC.
2. Turn on the printer. If the printer supports Plug-and-Play, and you have successfully connected it using a USB cable, then the Windows Add Hardware Wizard will automatically detect the printer and display a dialog that allows you to install a driver. Click Cancel and do not install the driver using this wizard.

3. Run the driver you downloaded from the Argox website. At the Windows Printer Driver prompt, select **"I accept..."** and click **"Next"**.

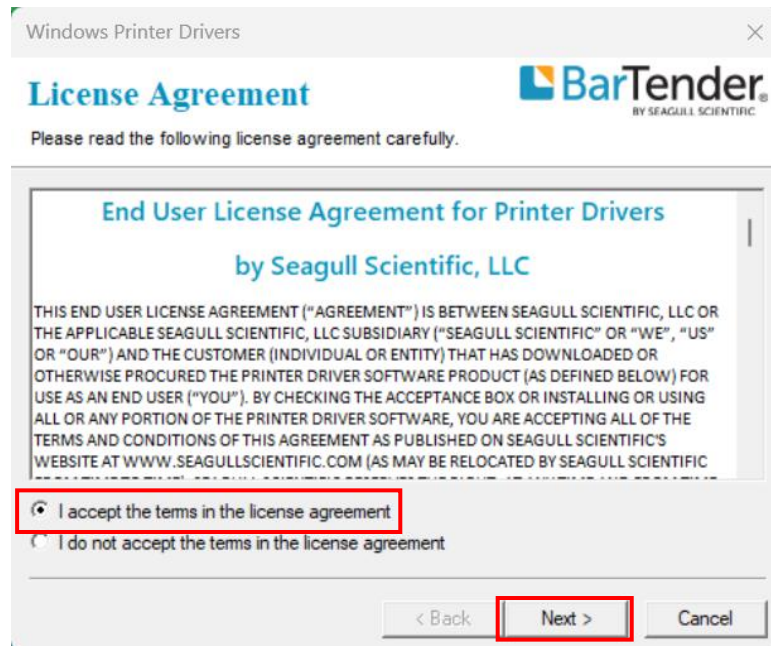

4. Assign the directory where you want to keep the Seagull driver (for example: C:\Seagull) and click **"Next"**.

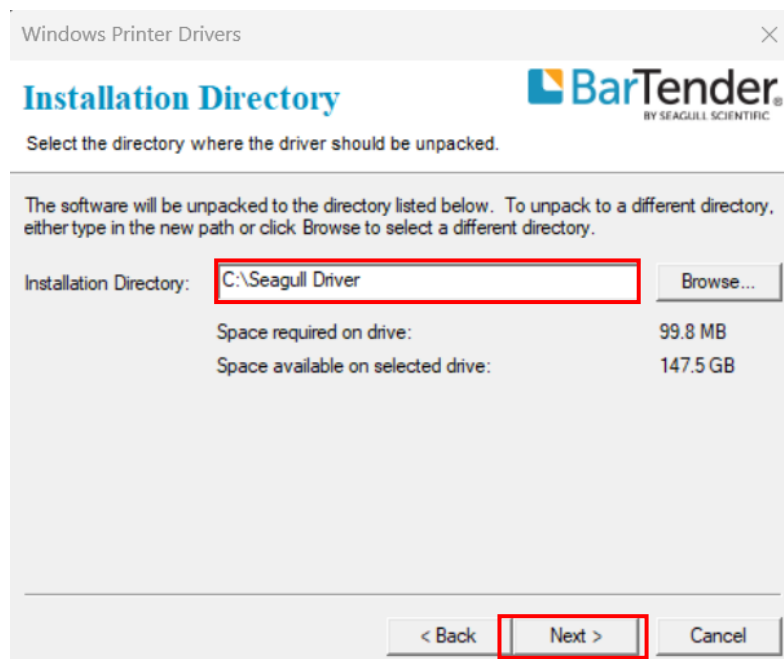

5. Click "**Finish**".

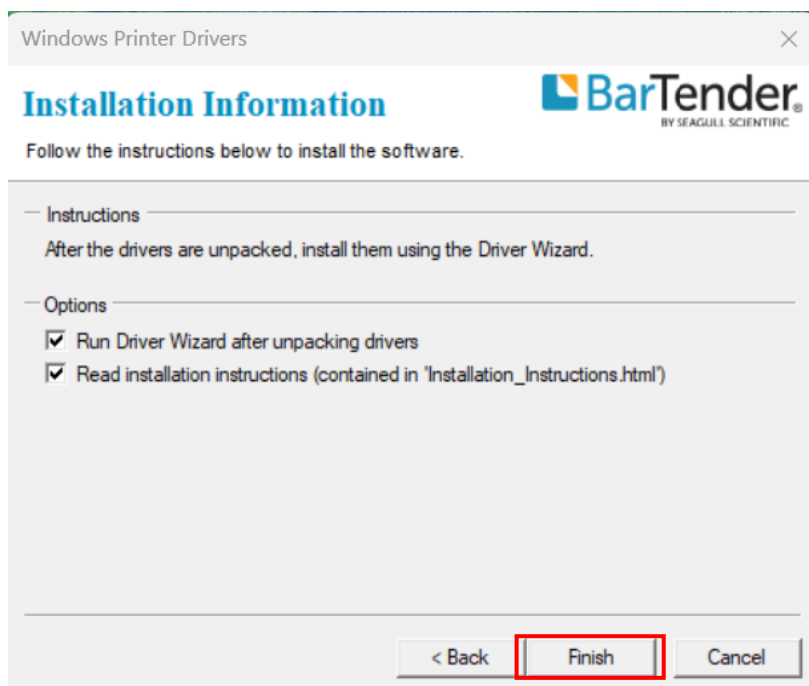

6. Select **Install printer drivers** and click "**Next**".



- At the Seagull Driver Wizard prompt, select the first radio button, '**Install a driver for a Plug and Play printer**'. Then click "**Next**".

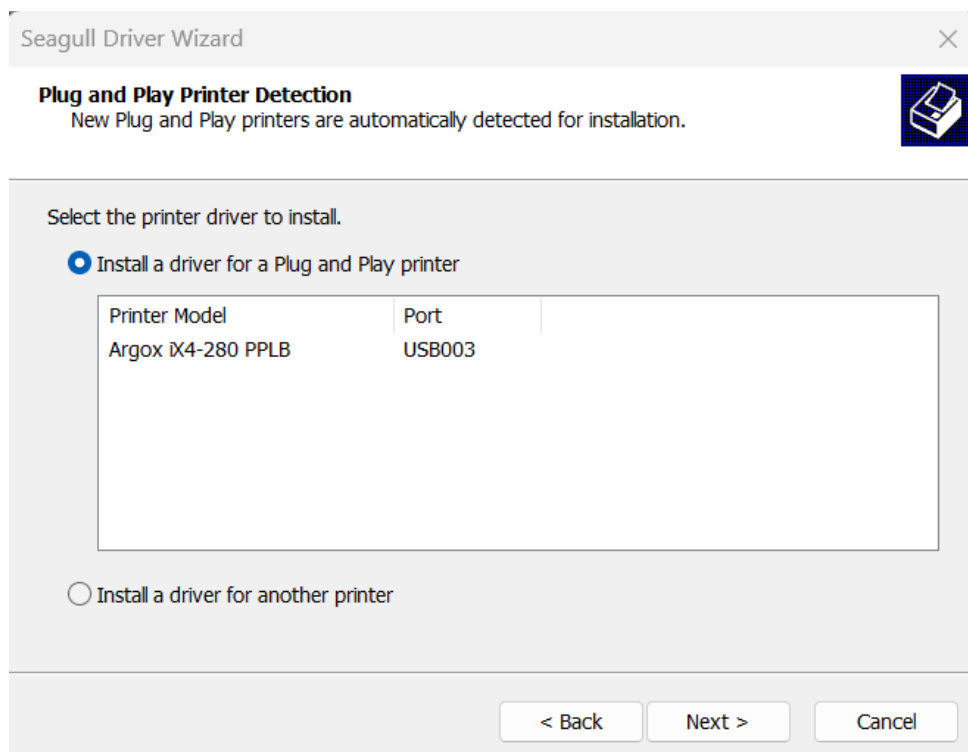

- Enter the name of the printer (e.g. Argox iX4-280 PPLB), select '**Do not share this printer**' and click '**Next**'.

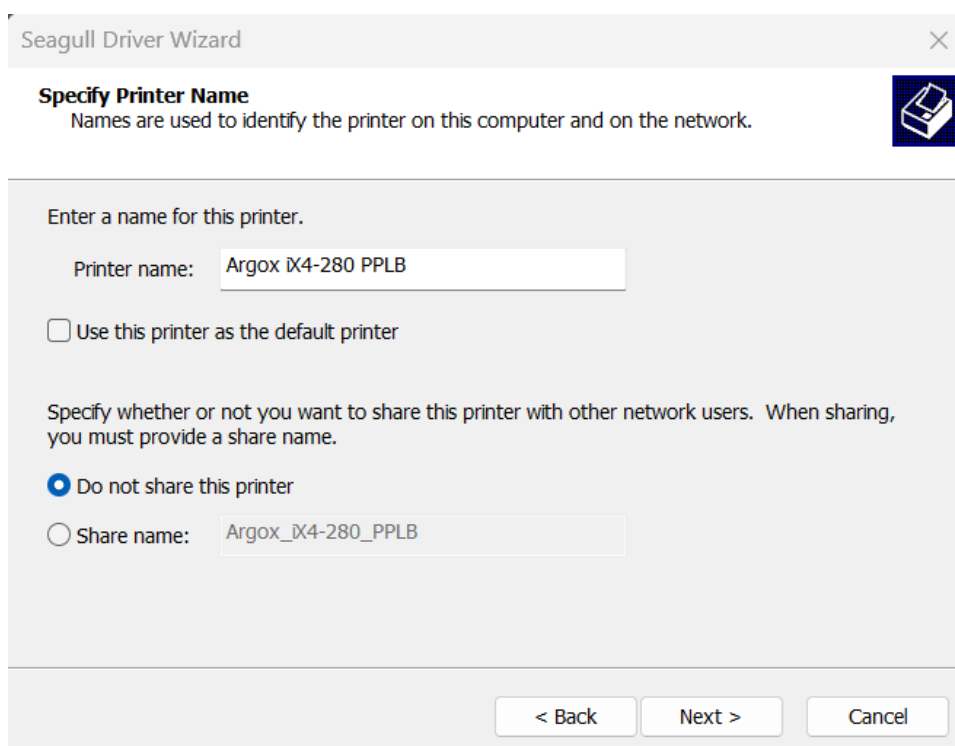

9. Check all the details on the screen and, if they are correct, click '**Finish**'.

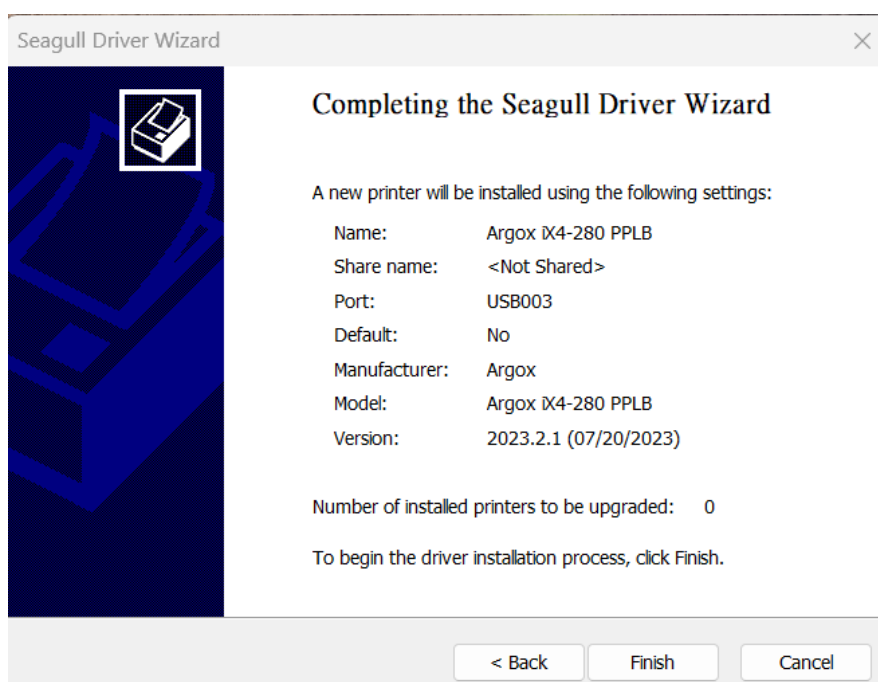

10. After the related files have been copied to your system, click '**Finish**'.

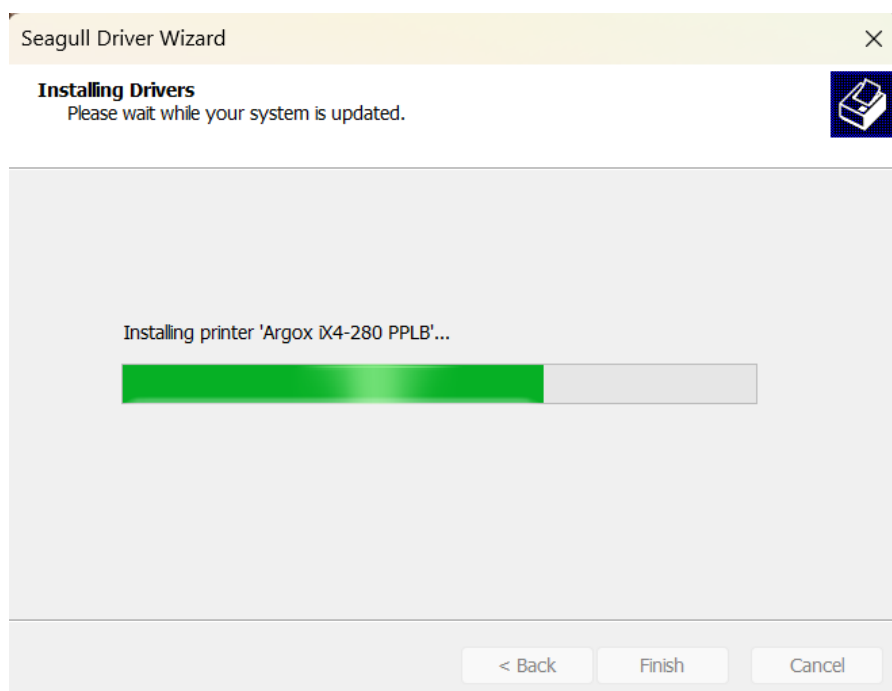

11. When the driver installation is complete, click '**Close**'. The driver should now be installed.

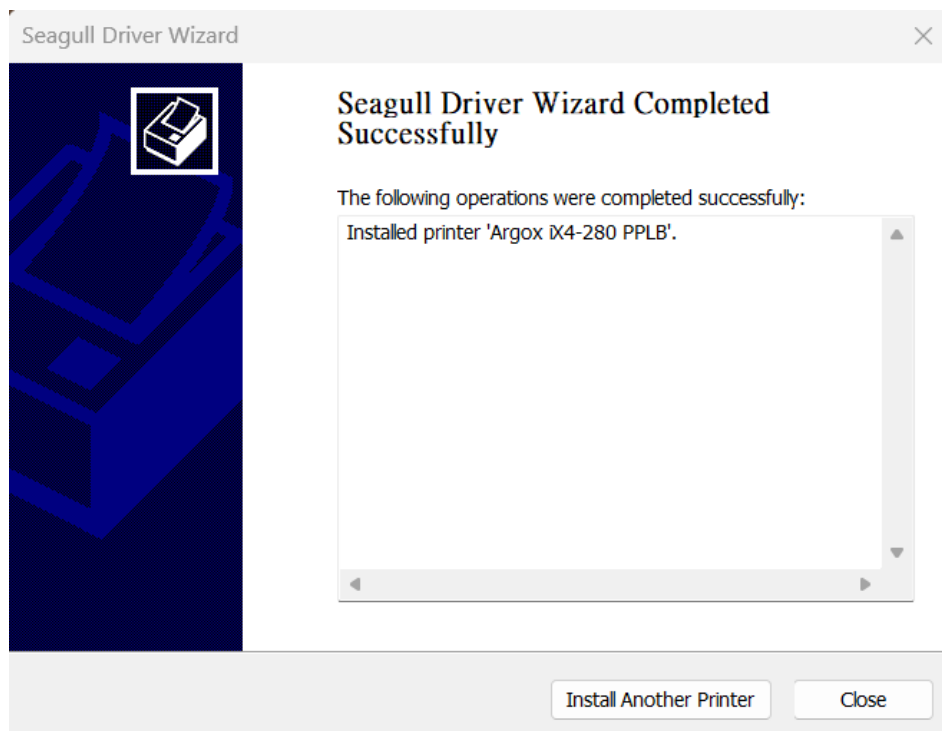

3.7.2 Installing a Printer Driver (for interfaces Other than USB)

1. Switch off the printer. Plug the power cable into the wall socket and then plug the other end of the cable into the power socket on the printer. Connect the parallel, serial or Ethernet cable to the appropriate port on the printer and your computer.
2. Run the driver from the Argox website. At the Windows Printer Driver prompt, select "**I accept...**" and click "**Next**".

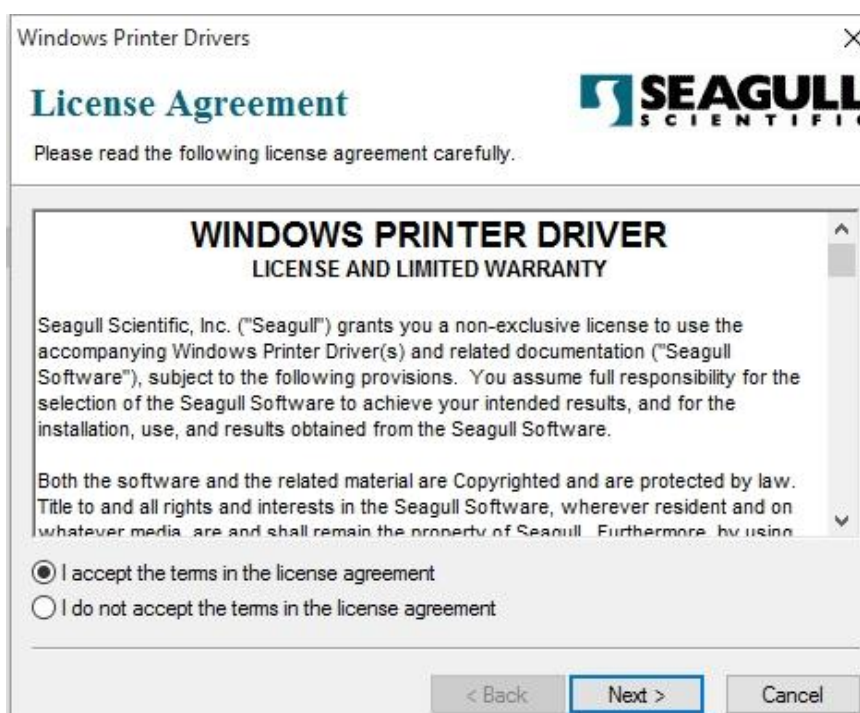

3. Assign the directory where you want to keep the Seagull driver (for example: C:\Seagull) and click 'Next'.

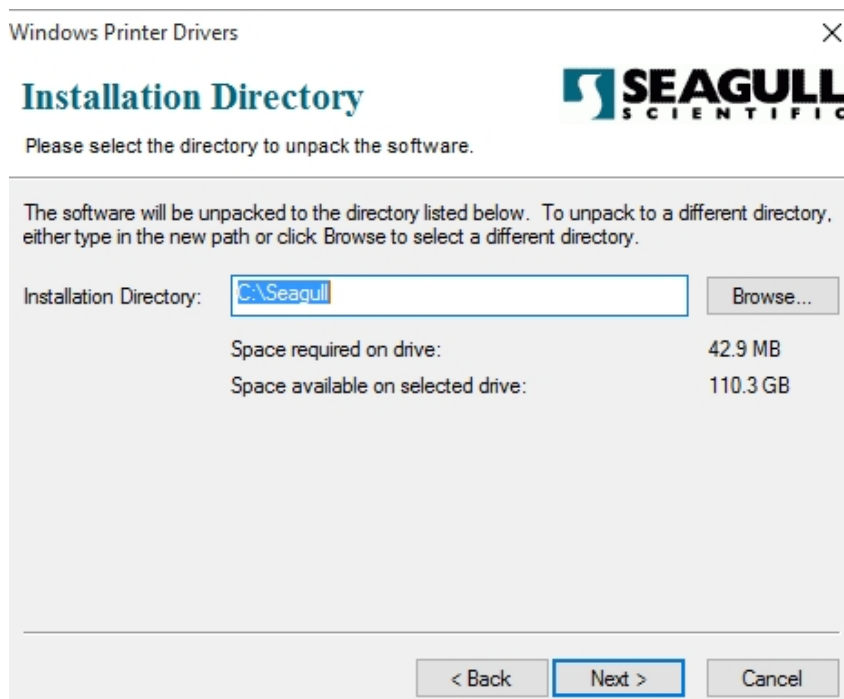

4. Click 'Finish'.

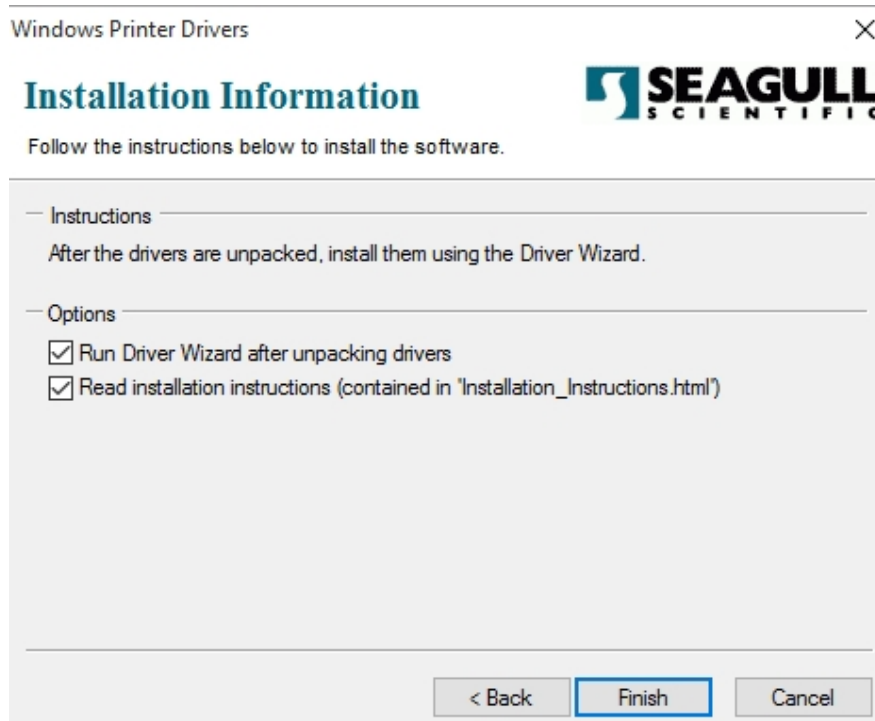

5. Select **Install printer drivers** and click '**Next**'.



6. Make sure the printer is connected to the PC, select '**Other**' and click '**Next**'.

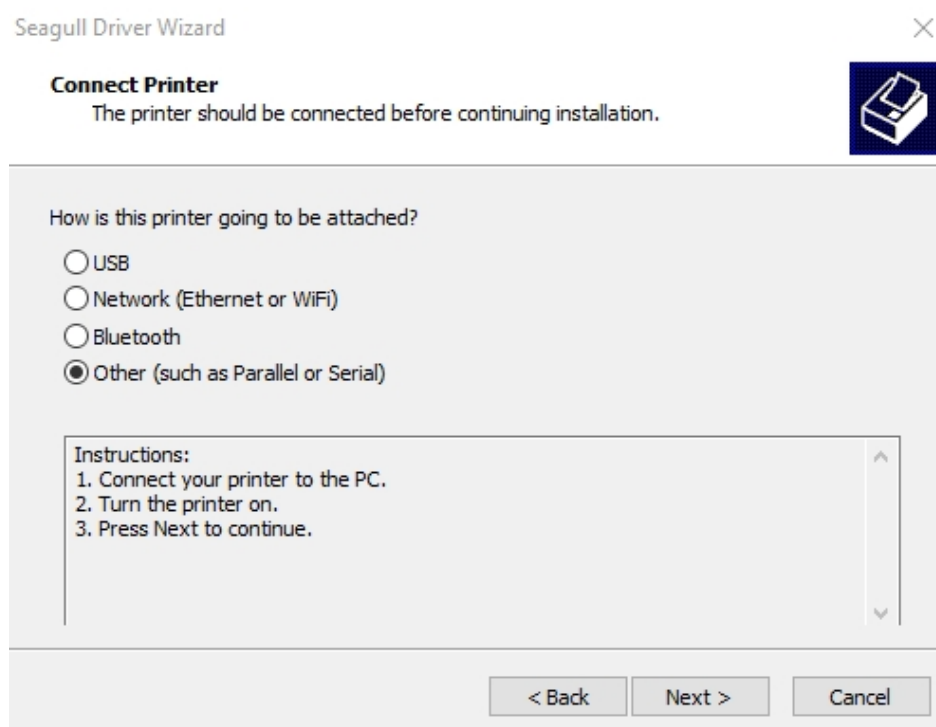

7. Select a model and emulation - the following examples are based on the iX4-280 PPLB model.

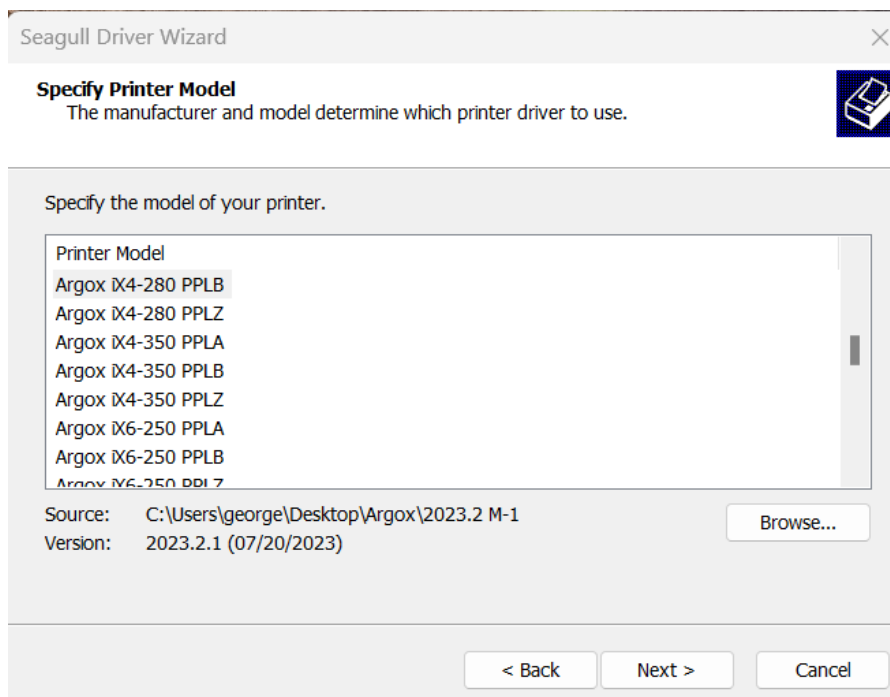

8. Select a port of the printer and click 'Next'.

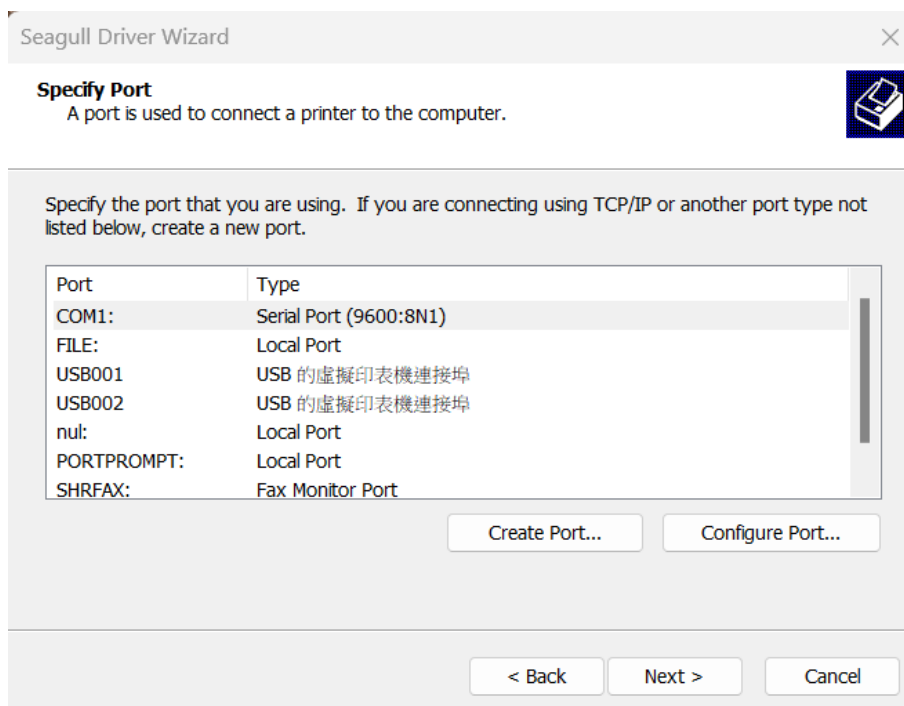

9. Enter the printer name (e.g. Argox iX4-280 PPLB), select "**Do not share this printer**" and click "**Next**".

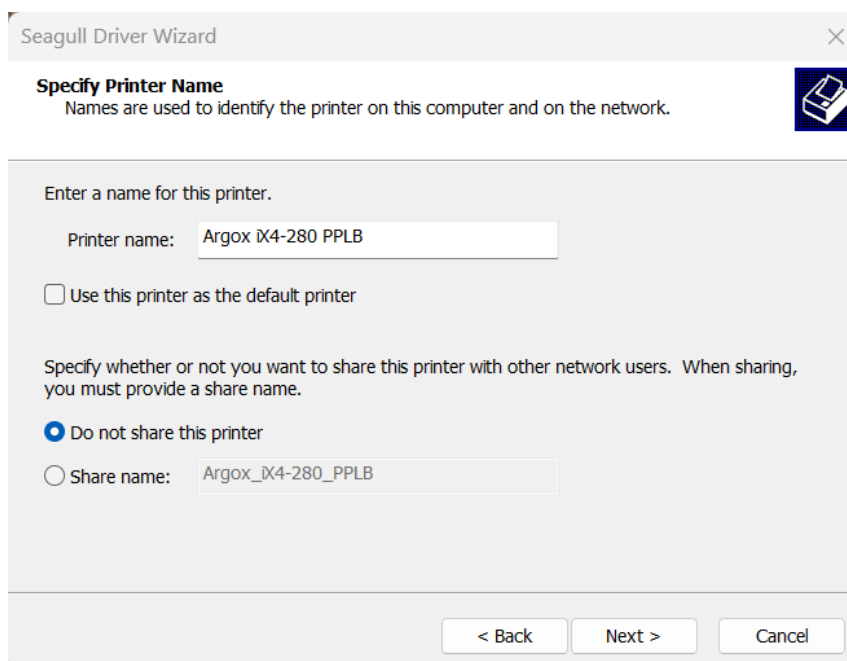

10. Check all the information on the screen and, if it is correct, click "**Finish**".

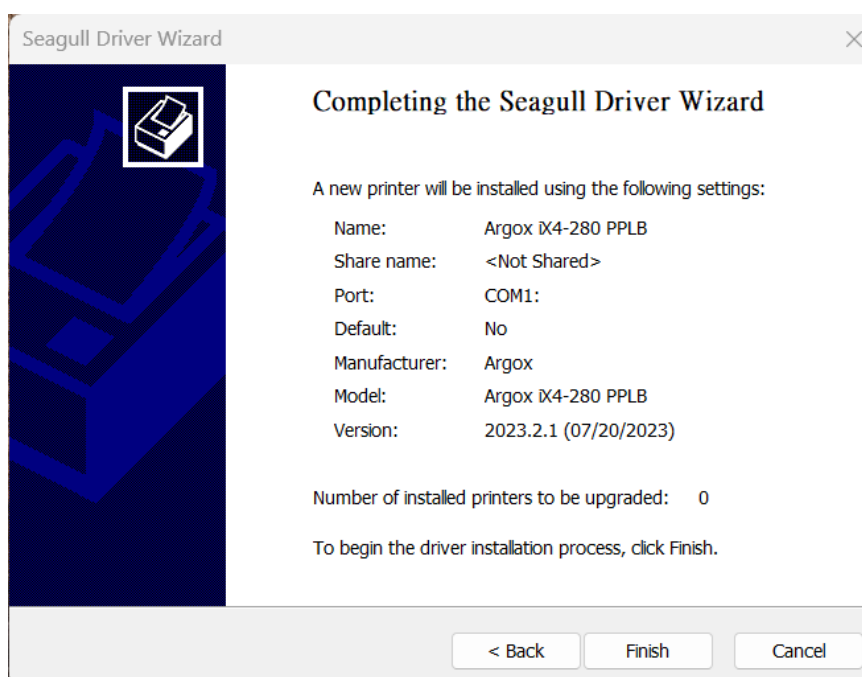

11. After the appropriate files have been copied to your system, click '**Finish**'.

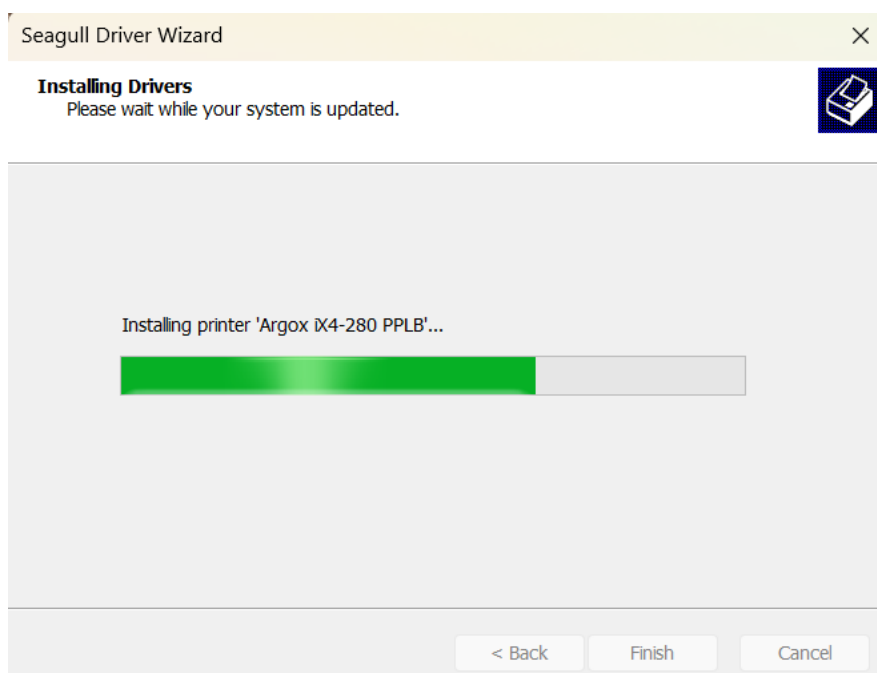

12. When the driver installation is complete, click '**Close**'. The driver should now be installed.

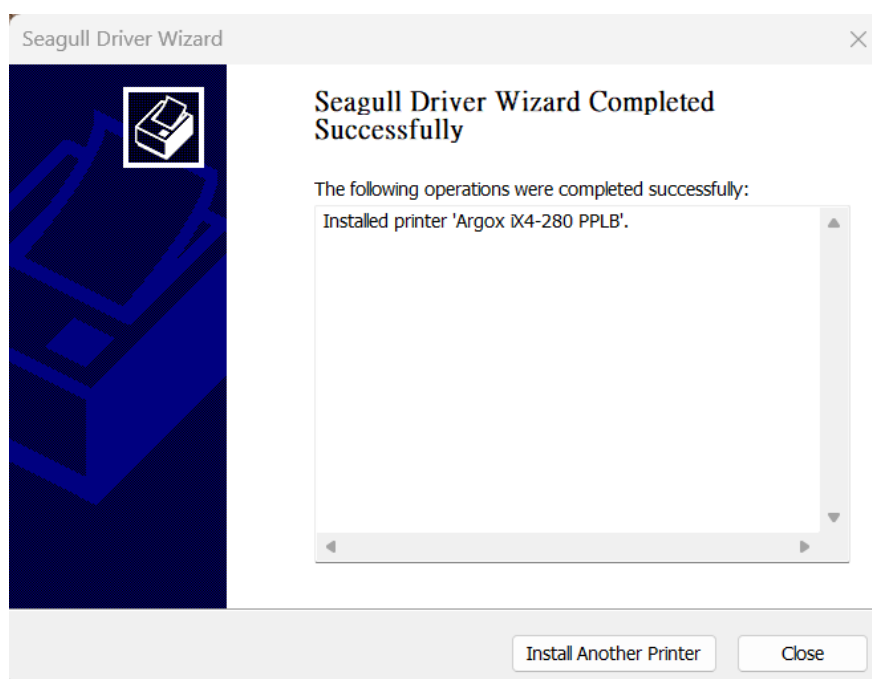

4 Configuration on Web Setting Tool

Before doing settings for your printer, be sure that you have a LAN cable. The cable is connected to the LAN connector of your printer. The LAN connector is an 8-PIN RJ45 type modular connector. Please use the LAN cable of CAT 5 of a proper length to connect the LAN connector on the printer to a LAN hub as appropriate.

The default static IP address of the printer is 0.0.0.0 and the default listen port is 9100. For the first time, to configure your printer through the web setting tool, you must still follow the step-by-step instructions below.

4.1 Attaching the power cord

1. Make sure the printer power switch is set to the **OFF** position.
2. Insert the power supply's connector into the printer power jack.
3. Insert the AC power cord into the power supply.

Important: Use only the power supply listed in the user instructions.

4. Plug the other end of the AC power cord into the wall socket.



Do not plug the AC power cord with wet hands or operate the printer and the power supply in an area where they may get wet.
Serious injury may result from these actions!

4.2 Connecting the printer to a LAN hub

Use a LAN cable of CAT 5 of a proper length to connect the LAN connector on the printer to a LAN hub to which your desktop or laptop PC as a host terminal is also connected.

4.3 Getting the IP address of the printer

You can have the printer run a self test to print a configuration label, which helps you get the IP address of your printer connected to the LAN hub.

1. Turn off the printer.
2. Press and hold the **FEED** button, and turn on the printer.
3. Both status lights glow solid amber for a few seconds. Next, they turn to green shortly, and then turn to other colors. When LED 2 turns to green and LED 1 turns to amber, release the **FEED** button.
4. Press the **FEED** button to print a configuration label.
5. Get the IP address of the printer from the printed configuration label.

4.4 Logging in to the web setting tool

The Web Setting Tool is a build-in setting tool in firmware for ARGOX serial printers. User can connect to the supported ARGOX serial printers with browsers to get or set the printer settings, update firmware, download font, etc.

After obtaining the IP address of the LAN printer from the printed configuration label, you can connect to the printer with the supported browsers by input the IP address of the printer, *for example, 192.168.6.185*, in the URL field and connect to it.

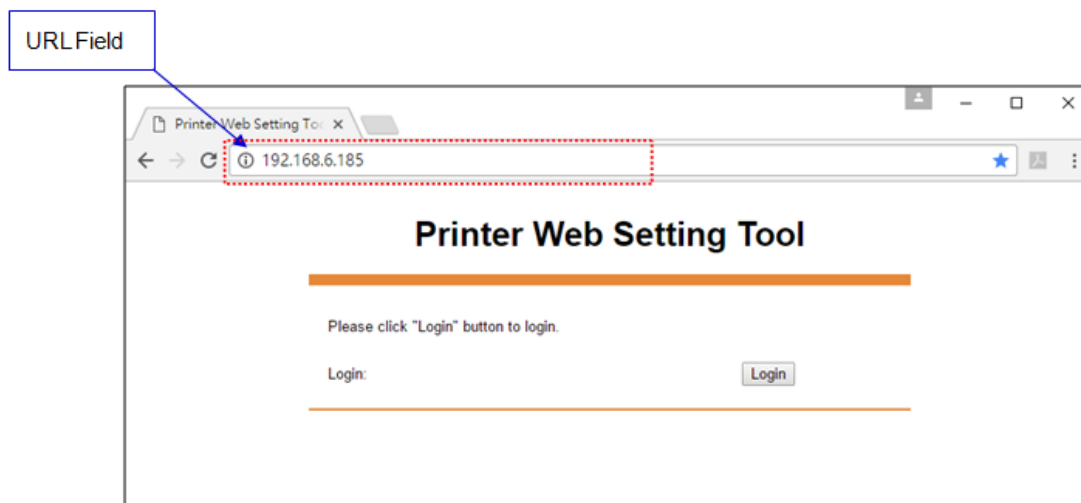

When the connection is successful, the Login page will be displayed. Input the user name and password to log in to the web setting tool. The default user name and the default password are given below:

Default user name: admin

Default password: admin

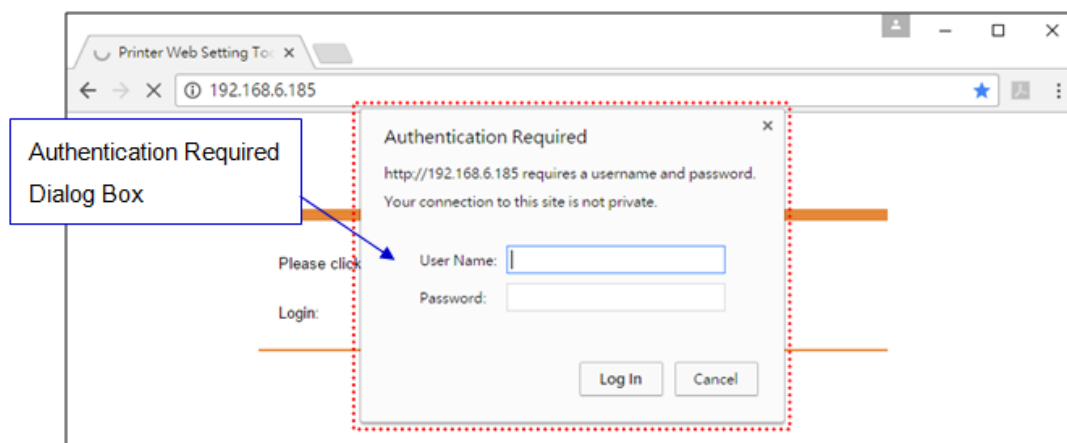

The default password can be changed in the "Device Setting \ Change Login Password" webpage.

This web setting tool can be used to manage multiple label printers in the same local area network segment under the Windows operating system as long as there is no conflicting IP address in the network. You can also check each of the MAC addresses listed in this tool against the MAC address label you can find on each of the printers.

The label printer that is connected through TCP/IP in the way like a directly connected local printer can be used with a random PC connected in the same local area network segment. So, through the tool, all commands applicable to the LAN mode can work on the printer in the same way, as the printer must be configured upon the TCP/IP communication protocol with the IP address of the printer.

When doing settings through a tablet PC or Smart Phone for the printer working in infra mode, please set the same network segment of the host terminal to that of the printer, for example, 192.168.6.XXX (1~254). The Wi-Fi mode for the printer is infra mode that can be searched by the wireless device manager of the host terminal.

5 Maintenance

Vertical streaks in the printout usually indicate a dirty or defective print head. (See the following examples.) Clean the print head. If the problem persists, replace the printhead.

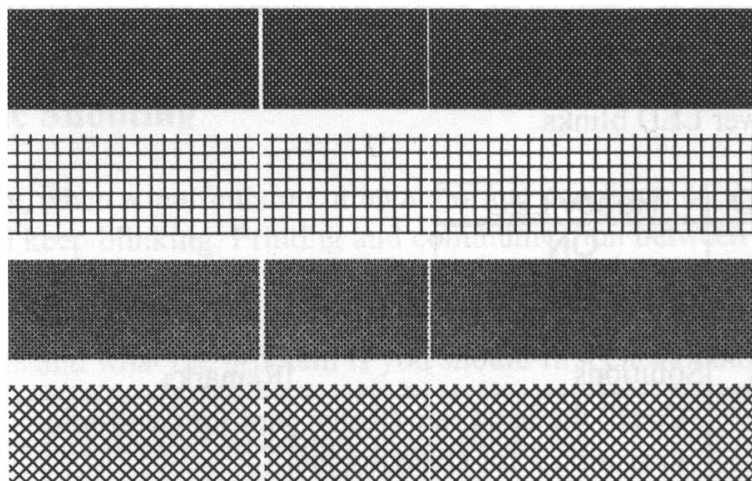

If the ribbon roll rotation is unstable, check the label path and make sure the head latch is securely closed.

Poor printout quality:

- The ribbon may not match the media in use.
- Adjust the darkness (heat temperature).
- Slow down the print speed.
- Refer to the following and clean the related spare parts.

5.1 Cleaning

To maintain print quality and extend the life of the printer, you must perform some routine maintenance. Daily maintenance is recommended for high volume printing and weekly maintenance is recommended for low volume printing.



Warning Always turn off the printer before cleaning.

5.1.1 Printhead

It is important to keep the printhead clean for the best print quality. We strongly recommend that you clean the printhead when you load a new roll of media. If the printer is used in a critical environment or if the print quality degrades, you will need to clean the printhead more frequently.

Keep these things in mind before cleaning:

- Keep water away from heating elements in case of corrosion.
- If you have just finished printing, wait until the printhead has cooled down.
- Do not touch the printhead with bare hands or hard objects.

Cleaning steps:

1. Moisten a soft cloth or a cotton swab with ethyl alcohol.
2. Gently wipe the printhead in one direction. That is, wipe it only from left to right or vice versa. Do not wipe back and forth in case dust or dirt reattaches to the printhead.



Note The printhead warranty is void if the printhead serial number is removed, altered, defaced or made illegible under any circumstances.

5.1.2 Platen Roller

The platen roller is also important for print quality. A dirty platen roller can damage the printhead. Clean the platen roller immediately if adhesive, dirt, or dust accumulates on it.

1. Dampen a soft cloth with absolute ethyl alcohol.
2. Gently wipe the platen roller to remove the dust and adhesive.

5.2 Printer Adjustments

5.2.1 Printer Head Pressure Adjustment



Note The printer head pressure adjustment is available to Ix4-280 model which is with the serial number of 21C58061 or former. You can also contact your local service center or printer supplier for technical support.

Printing quality can be fine adjusted based on which area on the label the printing quality discrepancy is located. There are two ways to enhancement pressure. Spring pressure pad can be quickly adjusted in three levels can for pressure numerous. A dial is provided to allow the operator to slightly adjust the pressure.

TPH Pressure Adjustable
(3 Levels)

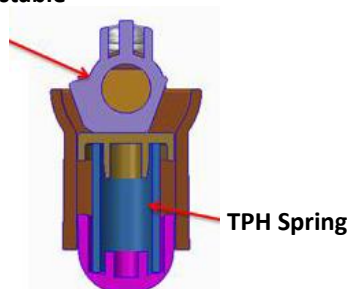

Spring pressure pad

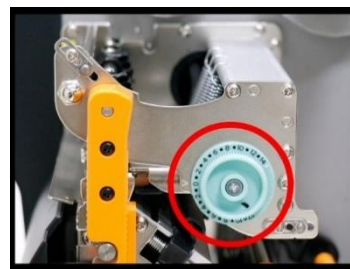

Scale dial

Adjust Spring pressure pad

Step.1 Please use either tool to switch the pressure level.

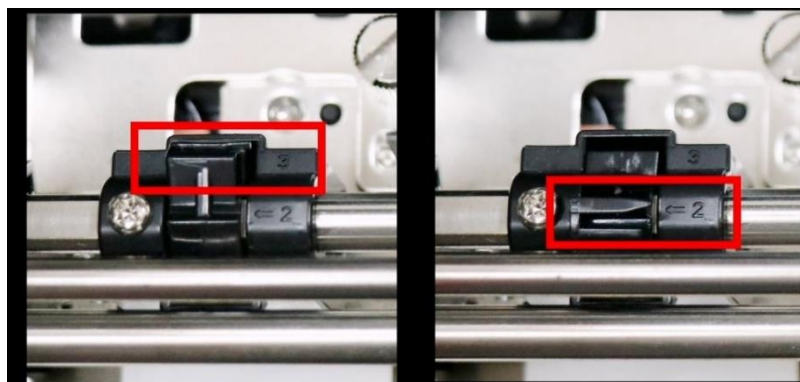

Step.2 Move the pad in one of the 3 positions. Among Position 1, Position 2 and Position 3, Position 3 is the thickest. If you want more pressure, move pad to position 3.

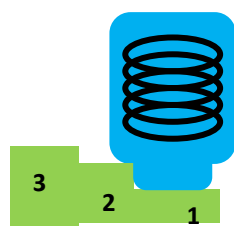

Switch to position 1 (- pressure)

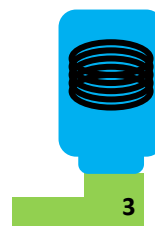

Switch to position 3 (+ pressure)

Adjust printer head rack

Step.1 Turn the dial in clockwise or counterclockwise direction.

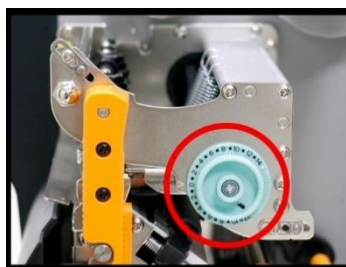

Step.2 Turn printer head rack clockwise to increase pressure or counterclockwise to decrease pressure.

Clockwise (+ pressure)



Counter-clockwise (- pressure)

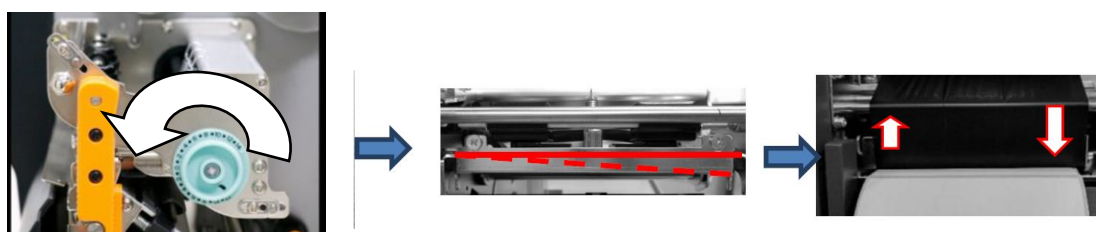

Repeat the same process until the printing quality is well balanced on both ends of the label. Once the desired quality has been reached, please make note on the new setting of **Adjust Spring pressure pad, printer head rack position** and the type number of ribbon used in this printing task for future reference.



Note To print small labels, such as 1-2 inch labels, please adjust the pressure range of the print head.

5.2.2 Ribbon Tension Adjustment

Both ribbon supply spindle and ribbon pickup spindle are equipped with control knobs to adjust ribbon tension. The control knobs can rotate to both directions.

If the ribbon is wrinkled at ribbon supply, rotate clockwise control knob of ribbon supply, to increase ribbon tension at ribbon supply and further improve ribbon wrinkle.

- Rotate control knob clockwise to increase ribbon tension.

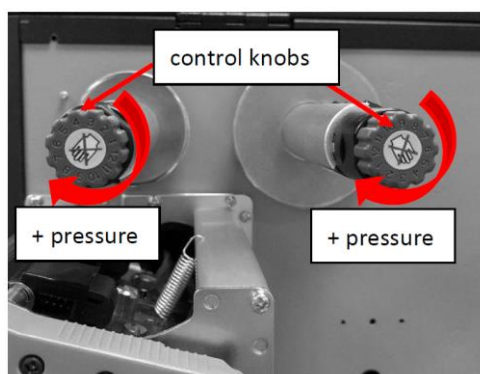

Too much tension at ribbon supply may result in ribbon not moving smoothly. Once it happens, rotate counterclockwise control knob of ribbon supply, to reduce ribbon tension to balance the tension.

- Rotate control knob counterclockwise to reduce ribbon tension.

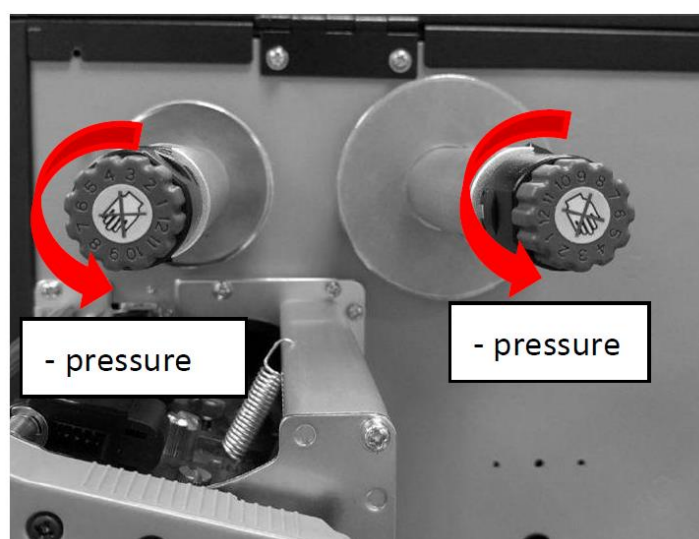

[Remark]:

The ribbon shaft has its user-friendly feature to allow users to adjust the tension of ribbon shaft by rotating the knob. User can reset to factory default tension by adjusting the ribbon shaft while the black line was aligned to the marked arrows. The default setting when shipped from Argox factory is shown as Figure 2 – the two arrows are in line with the black line.



Note If the ribbon is wrinkled at ribbon pickup, rotate counter-clockwise control knob of ribbon pickup, to decrease ribbon tension at ribbon pickup and further improve ribbon wrinkle. If the tension is too little at ribbon pickup, ribbon will not move smoothly, and needs control knob to rotate clockwise to increase tension.

5.2.3 Printing Wrinkle Adjustment

During printing, ribbon may wrinkle and cause abnormal printing quality. The following describes how to solve ribbon wrinkle accordingly.



Once the printouts as above appear, the possible cause may be the unequal positions of Ribbon Bracket, which needs to be adjusted properly to make its heights equally the same at both sides. Steps to adjust are as below:

1. Loosen the screws at both sides and rotate counter-clockwise:

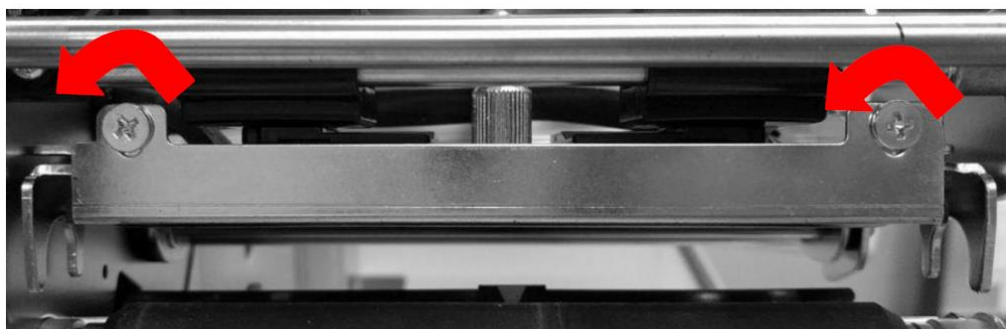

2. Make sure the Ribbon Bracket is at its **lowest** position first; then tighten up the screws by rotating clockwise.

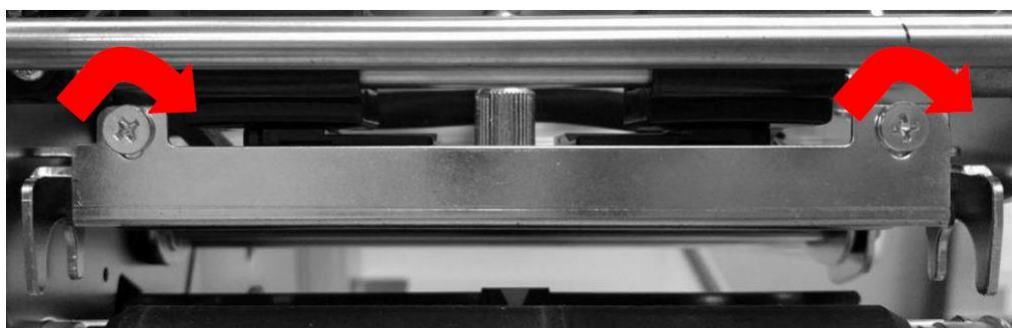

3. Alternatively, please reduce the occurrence of ribbon wrinkles through the ribbon wrinkle adjustment mechanism on both ends.

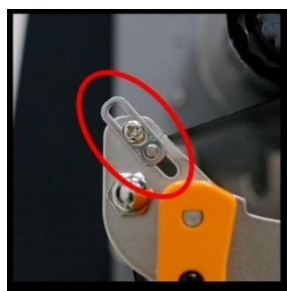

For Ribbon Rewind



For Ribbon Supply

4. Also alternatively, if you need to print smaller media, you can use the latch for the TPH of the printer to secure the small-sized media to prevent printing wrinkles during printing. You can loosen and remove the screw on the right side, move the right cam to the left, and then lock it back using the screw you just removed.



5. Print a test page to check print quality. If the quality is improved, stop the adjustment; if not, continue with next step.
6. If the test print appears as below, remain the screw at the right of Ribbon Bracket fixed, then loose the screw at the left, and gradually fine-tune upward, until the print quality gets improved.



If the test print appears as Figure B, remain the screw at the left of Ribbon Bracket fixed, and then loose the screw at the right, and gradually fine-tune upward, until the print quality gets improved.



5.2.4 Small-size Media Offset Adjustment

To print on small media sizes, place the media against the media guide, as shown in the red circle below, to prevent the media from snaking or shifting.

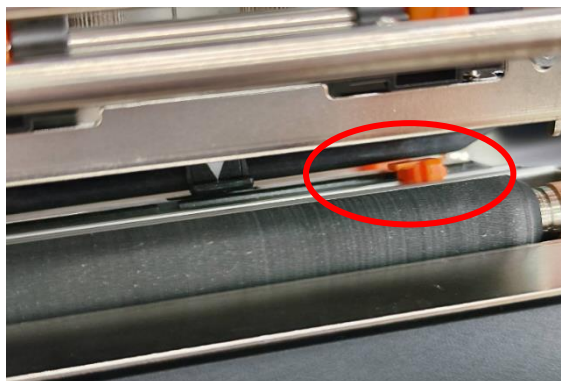

5.3 RTC Battery Replacement

RTC stands for real-time clock. It is a battery powered clock that keep track of the current date and time. If your printer has a built-in RTC, you'll find the RTC battery on the main board. The RTC battery keeps the RTC running even if the printer is turned off. If the battery is low or out, you need to replace it with a new one.

To replace a RTC battery:

1. Open the left cover of printer. Turn off the printer.
2. Locate the battery on the main board.
3. Remove the old coin battery and install a new one.
4. Turn on the printer.

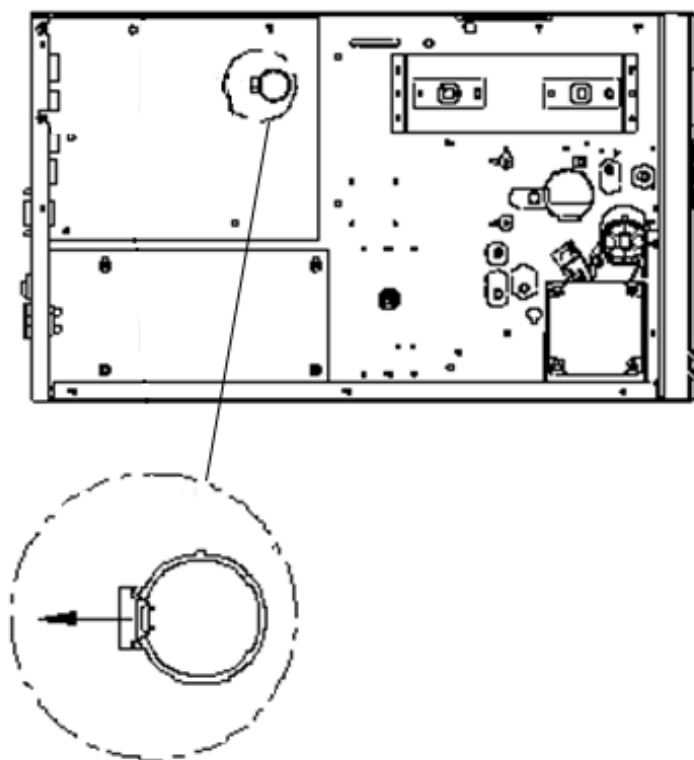

CAUTION:

Risk of explosion if battery is replaced by an incorrect type. Dispose of used batteries according to the instructions.

6 Troubleshooting

This chapter provides the information about printer problems and solutions.

6.1 Printer issues

The printer won't turn on

- Did you attach the AC power cord?
- Check the power connection from the wall socket to the printer. Test the power cord and the socket with other electrical devices.
- Disconnect the printer from the wall socket, and connect it again.

The printer turns itself off

- Turn on the printer again.
- If the printer keeps turning itself off, check the socket and make sure it has enough power for the printer.

The printer does not feed the media out

- The media is not loaded correctly. See Section 2.3, "[Loading Media](#)" to reload the media.
- If there is a paper jam, clear it.

6.2 Media issues

The media is out

- Load a new media roll.

The paper is jammed

- Open the printer and clear the jammed paper.
- Make sure the paper is held properly by the **Media Guides**.

The printing position is not correct

- Did you use the correct media type for printing?
- The media is not loaded correctly. See Section 2.3, "[Loading Media](#)" to reload the media.
- The media sensor needs to be calibrated. See Section 3.2, "[Printing Media Calibration & Configuration](#)" to calibrate the sensor.
- The media sensor is dirty. Clean the media sensor.

Nothing is printed

- The media is not loaded correctly. See Section 2.3, "[Loading Media](#)" to reload the media.
- The print data might not be sent successfully. Make sure the interface is set correctly in the printer driver, and send the print data again.
- Make sure the media and ribbon are both matched.

The print quality is poor

- The printhead is dirty. Clean the printhead.
- The platen roller is dirty. Clean the platen roller.
- Adjust the print darkness, or lower the print speed.
- The media is incompatible for the printer. Use appropriate media roll instead.

6.3 Ribbon issues

The ribbon is out

- Load a new ribbon roll.

The ribbon is broken

- Check the print darkness and adjust it if it is too high, and take the following steps to fix the broken ribbon:
 1. Unload the ribbon supply roll and take-up roll from the printer.
 2. Pull the ribbon from the supply roll so it overlaps the broken end of the take-up roll.
 3. Tape the overlapped parts together.
 4. Reload both rolls into the printer.

The ribbon is “printed out” with the media

- The ribbon is not loaded correctly. See Section 2.4, “[Loading Ribbon](#)” to reload the ribbon.
- The printhead temperature is too high. Reload the ribbon and print a configuration label to check the settings (See Section 3.2, “[Printing Media Calibration & Configuration](#)”). If the print darkness is very high, adjust it in printer preference, or reset your printer (see Section 3.3, “[Resetting to Factory Default Setting](#)”).

The ribbon is wrinkled

1. Make sure the ribbon is loaded correctly.
Rotate Thumb Wheel of Ribbon spindles to straighten the ribbon.

6.4 Other issues

There are broken lines in the printed label

- The printhead is dirty. Clean the printhead.

The printhead temperature is extremely high

- The printhead temperature is controlled by the printer. If it is extremely high, the printer will stop printing automatically, until the printhead is cool down. After that, the printer will resume printing automatically, if there is any unfinished print job.

The printhead is broken

- Contact your local dealer for assistance.

7 Specifications

This chapter provides specifications for the printer.

7.1 Printer

Model	iX4-280/380
Printing Method	Direct Thermal/Thermal Transfer
Printing Resolution	203 (8 dots/mm) / 300 dpi (12 dots/mm)
Printing Speed	iX4-280: Max. 10ips (304.8mm/s) (even with optional peeler and rewinder) iX4-380: Max. 8ips
Printing Length	iX4-280: 100" (2540mm) iX4-380: Max.50" (1270mm)
Printing Width	iX4-280: Max 4.13" (105mm) iX4-380: Max 4.16" (105.7mm)
Memory	128MB DRAM, 128MB Flash (USB storage up to 32GB)
CPU Type	32-bit RISC microprocessor
Sensors	Reflective sensor *1, Transmissive sensor *1
LCD	20*2 lines mono backlit LCD
Operation Interface	LED indicator x 3, Button x 3
Comm. Interface	Ethernet, USB device, RS-232, USB host
Fonts	Internal character sets standard 5 alpha-numeric fonts from 0.049" H ~ 0.23" H (1.25mm ~ 6.0mm) All fonts are expandable up to 24x24 4 direction 0 ~ 270 rotation Soft fonts are downloadable (up to 72 points)
Graphics	PPLA: PCX, BMP, IMG, HEX,GDI; PPLB: PCX, BMP, Binary raster, GDI; PPLZ: GRF, Hex, GDI
Emulation	iX4-280: PPLA / PPLB / PPLZ / Auto iX4-380: PPLA / PPLB / PPLZ / Auto
Software	BarTender, Printer Tool, Font Utility

Media Type	Roll-feed, die-cut, continuous, fan-fold, black mark, tags, ticket in thermal paper or plain paper
Media	Max. width: 4.48"(114mm); Min. width: 1"(25.4 mm) Thickness: 0.0025"~0.01" (0.0635mm~0.254mm); 8"(203mm)OD on a 3"(76mm) ID core Dealer Option 6" (152.4mm) OD on a 1.5"(38mm) ID core
Ribbon	Max. width: 4.4"(112 mm); Min. width: 1" (25.4 mm); Length: Max 450m Wax, Max OD 3.2" (81.3 mm); Core size ID 1"(25.4 mm); Wax, Wax/Resin, Resin (Ribbon wound ink-side out or ink-side in: auto-detect)
Dimensions	W 250 mm x H 260 mm x L 405 mm
Weight	13kgs
Power Source	Internal Universal Switching Power supply. Input voltage: 100~240V, 50~60Hz
Operation Environment	Operation Temperature: 40°F~104°F (4°C~40°C), 5% ~ 90% non-condensing; Storage Temperature: -4°F~122°F (-20°C~50°C)
Optional Items	Cutter, Peeler, Internal rewinder, External label rewinder, WiFi/BT combo module, GPIO kit
Agency Listing	CE, CB, FCC, cULus, BSMI, RoHS



Note Print quality and speed is based on 15% print coverage.

7.2 Media & Ribbon

Properties	Description
Media Size	Max. width:4.4" (112mm) Min. width: 1" (25.4 mm) Thickness: 0.0025"~0.01" (0.0635mm~0.254mm) 8.26" (210mm) OD on a 3" (76mm) ID core 7" (177.8mm) OD on a 1.5" (38mm) ID core Min. width 2.3" (58mm) for partial cutter options Min. length 1" (25.4mm) for cutter options
Media Type	Roll-feed, die-cut, continuous, fan-fold, tags, ticket or plain paper or label
Ribbon Size	Width: 1"~4" (25.4 mm~101.6 mm) Length: max 450m Wax, 450m Semi-Resin Max OD 3.2" (81.3 mm) Core size ID 1" (25.4 mm)
Ribbon Type	Wax, Wax/Resin, Resin (Ribbon wound ink-side out or ink-side in)

7.3 Electrical and operating environment

Properties	Description
Power Supply	Voltage: AC 100 V ~ 240 V ± 10 % (full range) Frequency: 50 Hz - 60 Hz ± 5 %
Temperature	Operating: 40°F~104°F (4°C~40°C) Storage: -4°F~122°F (-20°C~50°C)
Humidity	Operating: 25 %RH ~ 85 %RH (non-condensing) Storage: 10 %RH ~ 90 %RH (non-condensing)

7.4 Physical dimension

Dimension	Size and Weight
Size	W 250mm x H 263mm x D 418 mm
Weight	11 kg(24lbs)



Note The specifications may be changed at any time without prior notice. For more information about the new specifications, visit Argox website or contact your dealer.

7.5 Fonts, Barcodes, and Graphics Specification

The specifications for fonts, bar codes, and graphics depend on the printer emulation. The PPLA, PPLB, and PPLZ emulations are printer programming languages that allow the host to communicate with your printer.

Printer Programming Language PPLA

Programming Language	PPLA
Internal fonts	9 fonts with different point size 6 fonts with ASD smooth font Courier font with different symbol sets
Symbol sets (Code pages)	Symbol set for Courier font: Roman-8, ECMA-94, PC, PC-A, PC-B, Legal and PC437 (Greek), Russian
Soft fonts	Downloadable by Print Tool
Font size	1x1 to 24x24 times
Character rotation	0, 90, 180, and 270 degrees, 4 directions of rotation
Graphics	PCX, BMP, IMG, GDI and HEX format files
1D Barcodes	Code 39, UPC-A, UPC-E, Code 128 subset A/B/C, EAN-13, EAN-8, HBIC, Codabar, Plessey, UPC2, UPC5, Code 93, Postnet, UCC/EAN-128, UCC/EAN-128 K-MART, UCC/EAN-128 Random weight, Telepen, FIM, Interleaved 2 of 5 (Standard/with modulo 10 checksum/with human readable check digit/with modulo 10 checksum & shipping bearer bars), and GS1 Data bar (RSS)
2D Barcodes	MaxiCode, PDF417, Data Matrix (ECC 200 only), QR code, Composite Codes, and Aztec

Printer Programming Language PPLB

Programming Language	PPLB
Internal fonts	5 fonts with different point sizes
Symbol sets (Code pages)	8 bits code page: 437, 850, 852, 860, 863, 865, 857, 861, 862, 855, 866, 737, 851, 869, 1252, 1250, 1251, 1253, 1254, and 1255 7 bits code page: USA, BRITISH, GERMAN, FRENCH, DANISH, ITALIAN, SPANISH, SWEDISH, and SWISS
Soft fonts	Downloadable by Print Tool
Font size	1x1 to 24x24 times
Character rotation	0, 90, 180, and 270 degrees, 4 directions of rotation
Graphics	PCX , Binary Raster, BMP, and GDI
1D Barcodes	Code 39, UPC-A, UPC-E, Matrix 2 of 5, UPC-Interleaved 2 of 5, Code 39 with check sum digit, Code 93, EAN-13, EAN-8 (Standard, 2/5 digit add-on), Codabar, Postnet, Code128 subset A/B/C, Code 128 UCC (shipping container code), Code 128 auto, UCC/EAN code 128 (GS1-128), Interleave 2 of 5, Interleaved 2 of 5 with check sum, Interleaved 2 of 5 with human readable check digit, German Postcode, Matrix 2 of 5, UPC Interleaved 2 of 5, EAN-13 2/5 digit add-on, UPCA 2/5 digit add-on, UPCE 2/5 digit add-on, and GS1 Data bar (RSS)
2D Barcodes	MaxiCode, PDF417, Data Matrix (ECC 200 only), QR code、 Composite Codes, and Aztec

Printer Programming Language PPLZ

Programming Language	PPLZ
Internal fonts	8 (A~H) fonts with different point sizes 8 AGFA fonts: 7 (P~V) fonts with fixed different point sizes (not scalable) 1 (0) font with scaling point size
Symbol sets (Code pages)	USA1, USA2, UK, HOLLAND, DENMARK/NORWAY, SWEDEN/FINLAND, GERMAN, FRANCE1, FRANCE2, ITALY, SPAIN, MISC, JAPAN, IBM850, Multibyte Asian Encodings, UTF-8, UTF-16 Big-Endian, UTF-16 Little-Endian, and Code page 1250, 1251, ,1252, 1253, and 1254
Soft fonts	Downloadable by Print Tool
Font size	1x1 to 10x10
Character rotation	0, 90, 180, 270 and degrees, 4 directions of rotation
Graphics	GRF, Hex and GDI
1D Barcodes	Code39, UPC-A, UPC-E, Postnet, Code128 subset A/B/C, Interleave 2 of 5, Interleaved 2 of 5 with check sum, Interleaved 2 of 5 with human readable check digit, Code 93, Code 39 with check sum digit, MSI, EAN-8, Codabar, Code 11, EAN-13, Plessey, GS1 Data bar (RSS), Industrial 2 of 5, Standard 2 of 5, and Logmars
2D Barcodes	MaxiCode, PDF417, Data Matrix (ECC 200 only), QR code, Composite Codes, and Aztec

7.6 Wireless LAN (Optional)

Properties		Wireless LAN I/F				
Hardware	Protocol	IEEE 802.11 b/g/n				
	Enabled Device	Wireless Printer				
	Operating Temperature	-20°C ~ + 85°C				
	Destination	USA	Europe			
	Frequency (Center Channel)	2412 ~ 2462 MHz	2412 ~ 2472 MHz			
	Channel	1 ~ 11 ch	1 ~ 13 ch			
	Spacing	5M Hz				
	Transmission Speed / Modulation	IEEE 802.11b	Transmission Method	Conforming to IEEE 802.11b DSSS method		
			Channel	Depending on the country		
			Data Transmission Speed / Modulation	11/5.5 Mbps: CCK 2 Mbps: DQPSK 1 Mbps: DBPSK		
			IEEE 802.11g	Transmission Method	Conforming to IEEE 802.11g OFDM method DSSS method	
				Channel	Depending on the country	
				Data Transmission Speed / Modulation	54/48 Mbps: 64 QAM 36/24 Mbps: 16 QAM 18/12 Mbps: QPSK 9/6 Mbps: BPSK	
IEEE 802.11n		Transmission Method	Conforming to IEEE802.11n OFDM method			
		Channel	(US)1-11ch (JP/DE)1-13ch			
		Data Transmission Speed / Modulation	20MHz: 6.5M / 7.2M / 13M / 14.4M / 19.5M / 21.7M / 26M / 28.9M / 39M / 43.3M / 52M / 57.8M / 58.5M / 65M /			

Properties		Wireless LAN I/F	
		72.2M (Auto-sensing)	
Antenna	External antenna		
Aerial power	802.11b	Max +15 dBm	
	802.11g	Max +17 dBm	
	802.11n	Max +17 dBm	
Software	Connection mode	Infrastructure and Adhoc	
	Default IP Address	192.168.1.1	
	Default Subnet Mask	255.255.0.0	
	Default ESSID	WIRELESS PRINTER	
	Security	IEEE 802.11i	
		Cryptography: WEP 128 bit, TKIP (WPA), and AES (WPA2)	
		Authorization: Open Key (for WEP) and PSK	
	Protocol (*)	TCP/IP, Socket, and DHCP	
Wireless LAN Parameter Setting and Status Monitor	Parameter Setting: Command (PC Setting Tool)		

7.7 Interfaces

This section provides information about I/O port specifications for the printer.

7.7.1 USB

There are two common types of USB connector. Typically, Type A is found on hosts and hubs, and Type B is found on devices. The figure below shows their pinout.

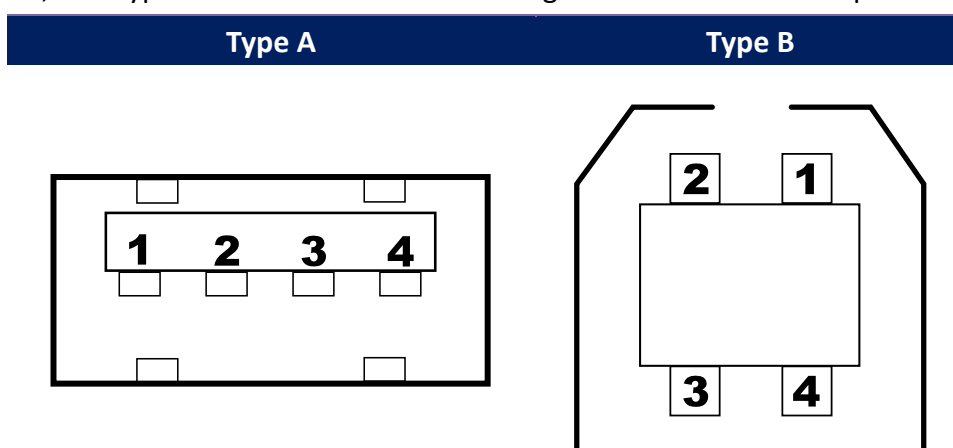

Pin	Signal	Description
1	VBUS	+5V
2	D-	Differential data signaling pair -
3	D+	Differential data signaling pair +
4	Ground	Ground

7.7.2 RS-232C

The RS-232C on the printer is a DB9 female connector. It transmits data bit by bit in asynchronous start-stop mode. The figure below shows its pin assignment.

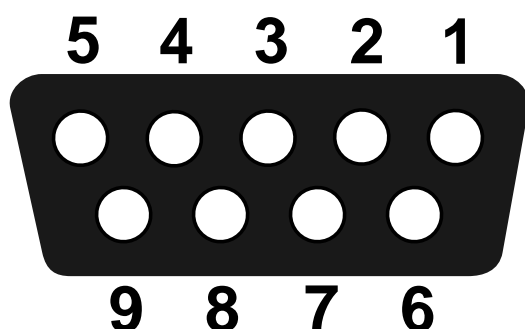

Pin	Signal	Description
1	NA	No Function
2	TxD	Transmit
3	RxD	Receive
4	NA	No Function
5	GND	Ground
6	NA	No Function
7	CTS	Clear to Send
8	RTS	Request to Send
9	NC	No Connection

Host (DB9)			Printer (DB9)		
Signal	Description	Pin	Pin	Description	Signal
CD	Carrier Detect	1	1	No Function	NC
RxD	Receive	2	2	Transmit	TxD
TxD	Transmit	3	3	Receive	RxD
DTR	Data Terminal Ready	4	4	No Function	NC
GND	Ground	5	5	Ground	GND
DSR	Data Set Ready	6	6	No Function	NC
RTS	Request to Send	7	7	Clear to Send	CTS
CTS	Clear to Send	8	8	Request to Send	RTS
CI		9	9	No Function	NC

7.7.3 GPIO

The input and output definitions are shown below.

DB15 Pin No.	Direction (Power / In / Out)	Name
1	Power	GND
2	Power	5V
3	Input	Start Print
4	Input	Feed
5	Input	Pause
6	Input	Reprint
7	Power	24V
8	Power	GND
9	NC	NC
10	Output	Ser_Req
11	Output	End_Print
12	Output	Media Out
13	Output	Ribbon Out
14	Output	Data Ready
15	Output	OPT_Fault

Initialization:

- (1) During the initialization process, please set all output ports to high for status clear; this means that all outputs are active low.
- (2) The active level may need to be adjusted.
- (3) The normal input state (idle) is high level, so all inputs are also active low.
- (4) Information About Printer GPIO Power Supply Settings is important, as listed below.

Isolated power supply:

- Do not install jumpers on J3 and J4.

Non-isolated power supply (5V):

- Short-circuit J3 pins 2 and 3 with a jumper.
- Short-circuit J4 pins 2 and 3 with a jumper.

Non-isolated power supply (24V):

- Short-circuit J3 pins 1 and 2 with a jumper.
- Short-circuit J4 pins 2 and 3 with a jumper.

7.7.4 Ethernet

The Ethernet uses an 8P8C (8-Position 8-Contact) RJ-45 cable. The figure below shows its pin assignment.

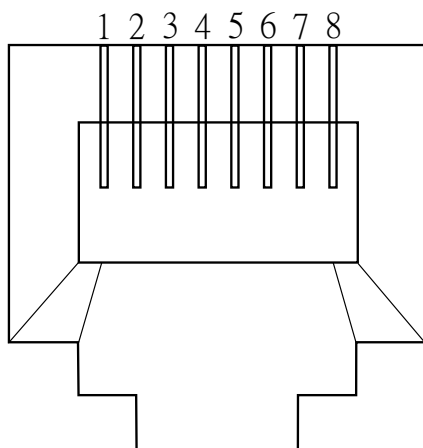

Pin	Signal
1	Transmit+
2	Transmit-
3	Receive+
4	Reserved
5	Reserved
6	Receive-
7	Reserved
8	Reserved