

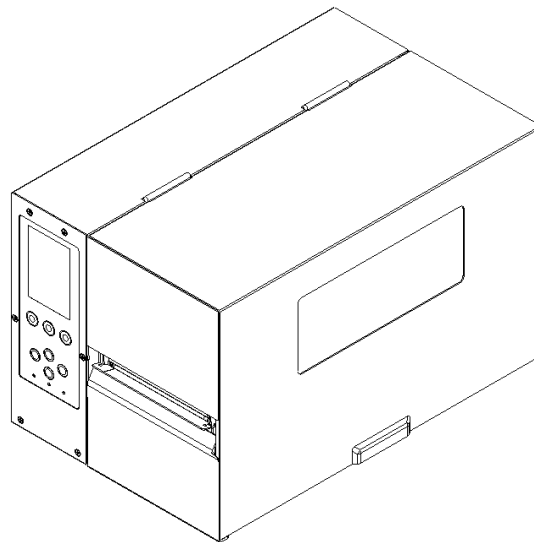

# XM4 Series Printer

## User Manual



<https://www.argo.com>

Version: 1.2

## Liability Disclaimer

Argox Corporation takes steps to assure that the company's published engineering specifications and manuals are correct; however, errors do occur. Argox reserves the right to correct any such errors and disclaims any resulting liability. In no event shall Argox or anyone else involved in the creation, production, or delivery of the accompanying product (including hardware and software) be liable for any damages whatsoever (including, without limitation, damages for loss of business profits, business interruption, loss of business information, or other pecuniary loss) arising out of the use of or the results of use of or inability to use such product, even if Argox has been advised of the possibility of such damages.

## FCC Compliance Statement

This equipment has been tested and found to comply with the limits for a Class A digital device, pursuant to Part 15 of the FCC Rules. These limits are designed to provide reasonable protection against harmful interference in a residential installation. This equipment generates, uses, and can radiate radio frequency energy and, if not installed and used in accordance with the instructions, may cause harmful interference to radio communications. However, there is no guarantee that the interference will not occur in a particular installation. If this equipment does cause harmful interference to radio or television reception, which can be determined by turning the equipment off and on, the user is encouraged to try to correct the interference by the following measures:

Reorient or relocate the receiving antenna.

Increase the separation between the equipment and the receiver.

Connect the equipment into a different outlet on a different circuit.

Consult the dealer or an experience Radio/TV technician for help.

This unit was tested with shielded cables on the peripheral devices. Shielded cables must be used with the unit to ensure compliance. The user is cautioned that any changes or modifications not expressly approved by Argox Information Co., Ltd. could void the user's authority to operate the equipment.

This is a Grade A product. In living environment, the product may cause interference to radio communications. In this case, the user is encouraged to try to correct the interference by effective measures.



**Caution**

Ensure to connect the power cord of power adapter to a socket-outlet with earth connection.

**CAUTION:** Risk of Explosion if Battery is replaced by an Incorrect Type. Dispose of Used Batteries According to the Instructions.

**ATTENTION:** Risque d'explosion si la batterie est remplacée par un type incorrect. Mettre au rebus les batteries usagées selon les instructions.

**Caution**

Any changes or modifications not expressly approved by the party responsible for compliance could void the user's authority to operate the equipment.

All rights reserved. Copyright © 2024 Argox Information Co., Ltd

# Contents

1	Introduction .....	1
1.1	Features .....	1
1.2	Unpacking.....	2
1.3	Understand your printer .....	3
1.3.1	Perspective view .....	3
1.3.2	Back view .....	4
1.3.3	Interior view .....	5
1.4	Printer control panel.....	6
1.4.1	Status lights.....	6
1.4.2	Buttons .....	8
2	Get started .....	9
2.1	Attach the power cord .....	9
2.2	Turn on/off your printer.....	10
2.2.1	Turn on your printer.....	10
2.2.2	Turn off your printer .....	11
2.3	Load media .....	12
2.3.1	Prepare media .....	13
2.3.2	Placing media roll.....	14
2.3.3	Media types .....	24
2.4	Load Ribbon.....	26
2.4.1	Placing Ribbon Roll .....	27
3	Printer operation .....	30
3.1	Front Panel .....	30
3.2	LCD Function Setting Procedure .....	31
3.3	Control / Navigation Buttons .....	32
3.4	Printer Setup Menu .....	33
3.4.1	Settings .....	34
3.4.2	System .....	38
3.4.3	Test 40	
3.4.4	Interface .....	41
3.4	Printing Media Calibration & Configuration.....	43
3.5	Printing a Configuration Report .....	43
3.6	Resetting to Factory Defaults.....	51
3.7	Media sensing.....	52
3.7.1	Transmissive sensor .....	52
3.7.2	Reflective sensor.....	53

3.7.3	Adjust Position of Label Sensor .....	54
3.8	Communications .....	55
3.8.1	Interfaces and Requirements .....	55
3.9	Driver installation .....	57
3.9.1	Installing a Plug and Play printer driver (for USB only) .....	57
3.9.2	Installing a Printer Driver (for other interfaces except USB) .....	62
4	Configuration on Web Setting Tool .....	67
4.1	Attaching the power cord .....	67
4.2	Connecting the printer to a LAN hub .....	67
4.3	Getting the IP address of the printer .....	68
4.4	Logging in to the web setting tool .....	68
5	Maintenance .....	70
5.1	Cleaning .....	71
5.1.1	Printhead .....	71
5.1.2	Platen Roller .....	72
5.2	Printer Adjustments .....	72
5.2.1	Printer Head Pressure Adjustment .....	72
5.2.2	Ribbon Tension Adjustment .....	74
5.2.3	Printing Wrinkle Adjustment .....	76
5.2.4	Small-size Media Offset Adjustment .....	78
5.3	RTC Timer Battery Replacement .....	79
6	Troubleshooting .....	80
6.1	Printer issues .....	80
6.2	Media issues .....	81
6.3	Ribbon issues .....	82
6.4	Other issues .....	83
7	Specifications .....	84
7.1	Printer .....	84
7.2	Media & Ribbon .....	85
7.3	Electrical and operating environment .....	85
7.4	Physical dimension .....	86
7.5	Fonts, Barcodes, and Graphics Specification .....	86
7.6	Interfaces .....	89
7.6.1	USB .....	89
7.6.2	RS-232C .....	90
7.6.3	GPIO .....	91
7.6.4	Ethernet .....	92

# 1 Introduction

Thank you for purchasing an Argox XM4 Series industrial barcode printer. This manual provides information about how to set up and operate your printer, load media, ribbon and solve common problems. Illustrations are provided to help you quickly become familiar with the printer.

## 1.1 Features

- **Fast Print Speed**  
Max. 12 IPS, fastest print speed in its class
- **Communication**  
Standard: Ethernet, dual USB hosts, USB device, and RS-232  
Option: Wi-Fi, GPIO, and Buzzer
- **Online management**  
Web management and SNMP v2 support
- **Dual USB host function**  
Stand-alone mode of scanner/ keyboard multiple data entry devices
- **New media calibration**  
Intelli mode & Auto-feed mode & Smart mode

## 1.2 Unpacking

Make sure all of the following items are included in your package.

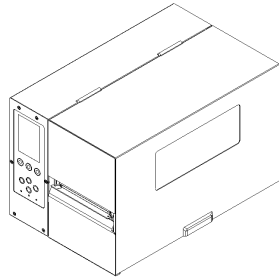

Printer

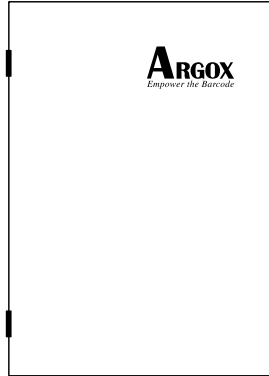

Quick Installation  
Guide

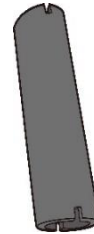

1" ID Core for Ribbon

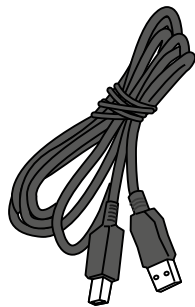

USB Cable



AC Power Cord

When you receive the printer, open the package immediately and inspect for shipping damage. If you discover any damage, contact the shipping company and file a claim. Argox is not responsible for any damage incurred during shipping. Save all package materials for the shipping company to inspect.



**Note** If any item is missing, please contact your local dealer.

## 1.3 Understand your printer

### 1.3.1 Perspective view

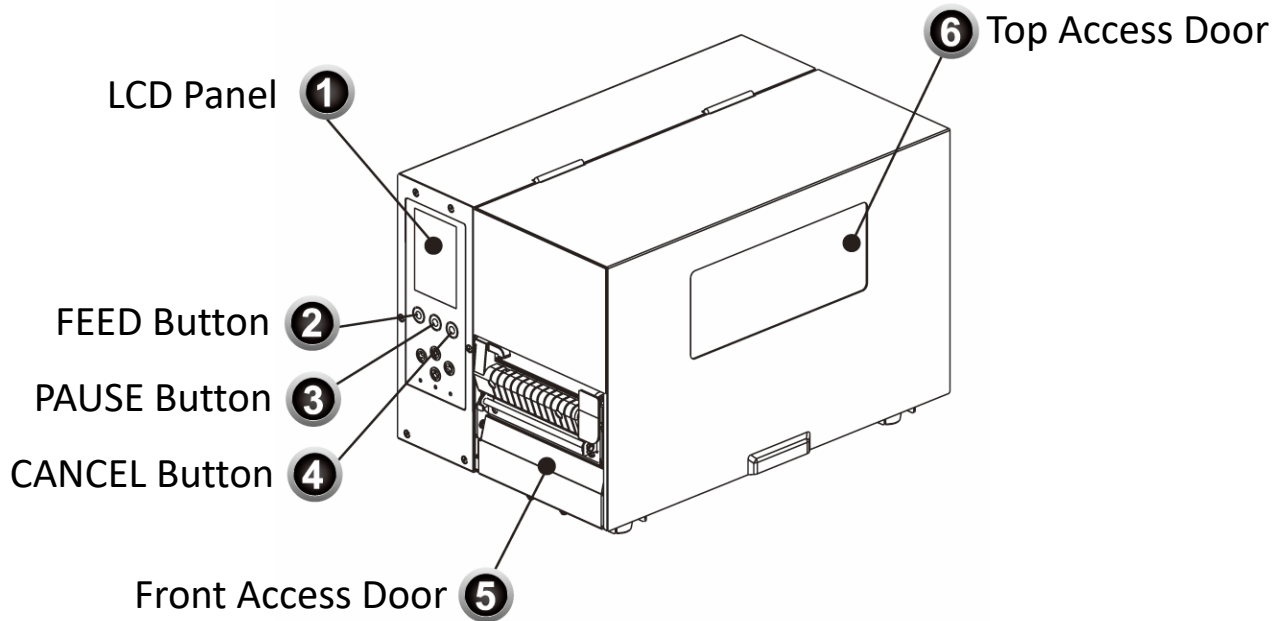



## 1.3.2 Back view

### Standard

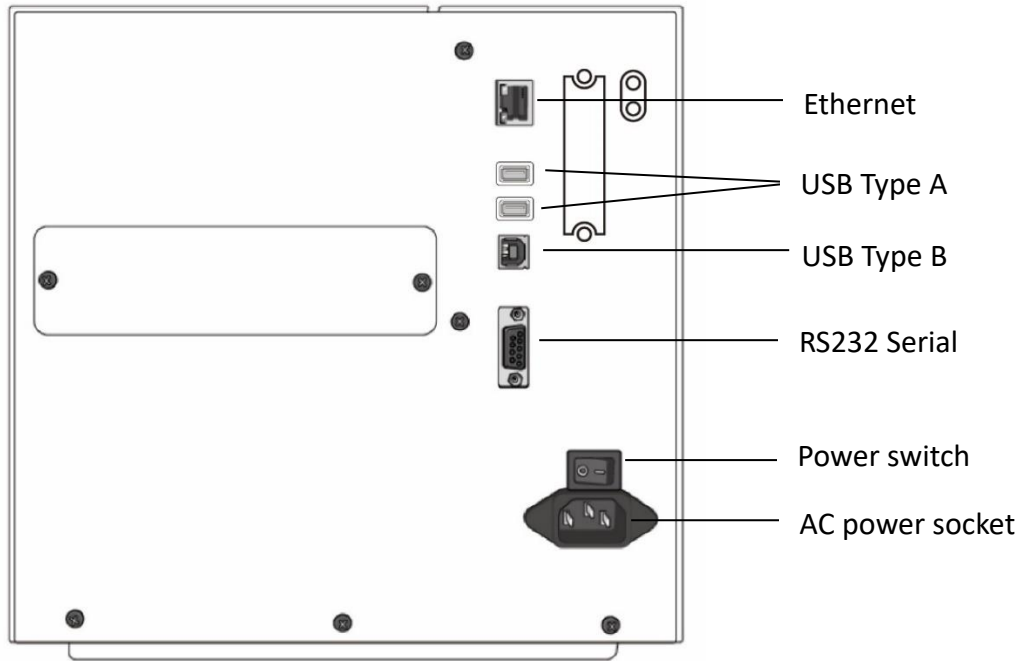

### Optional

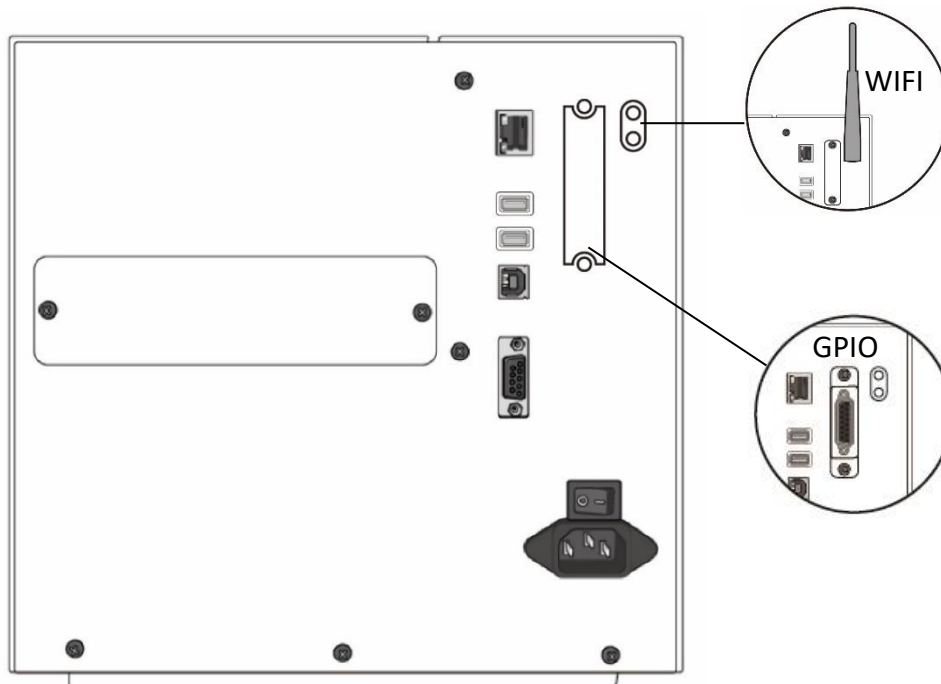

## 1.3.3 Interior view

### Internal Parts and Features

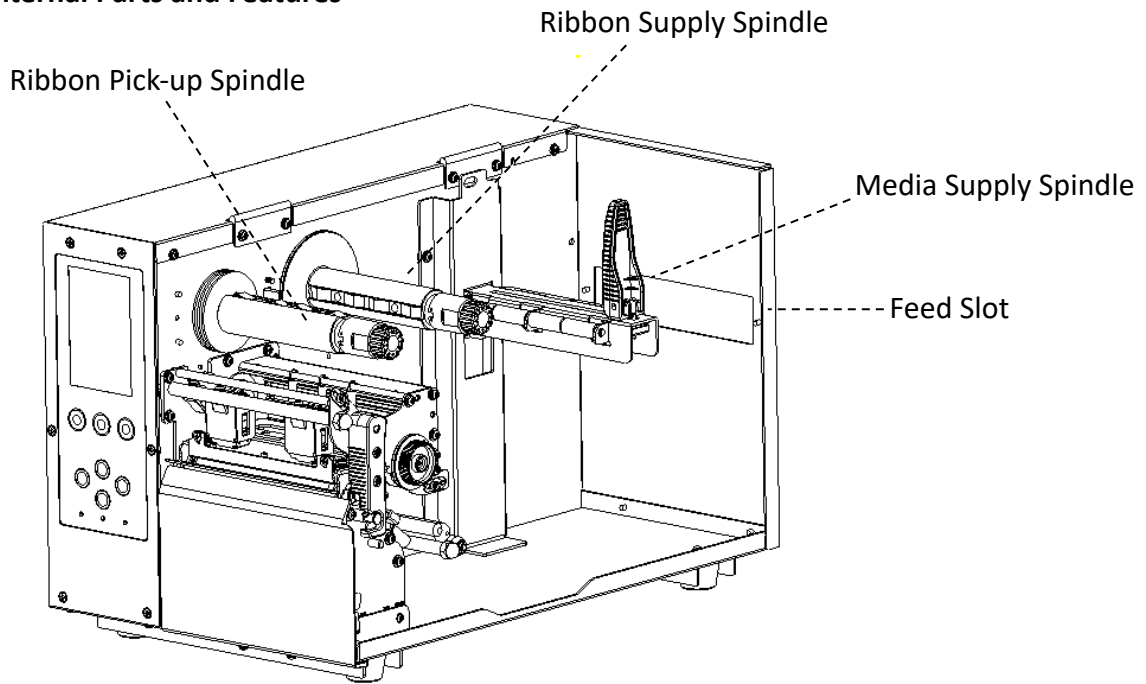

### Rotate Head Latch

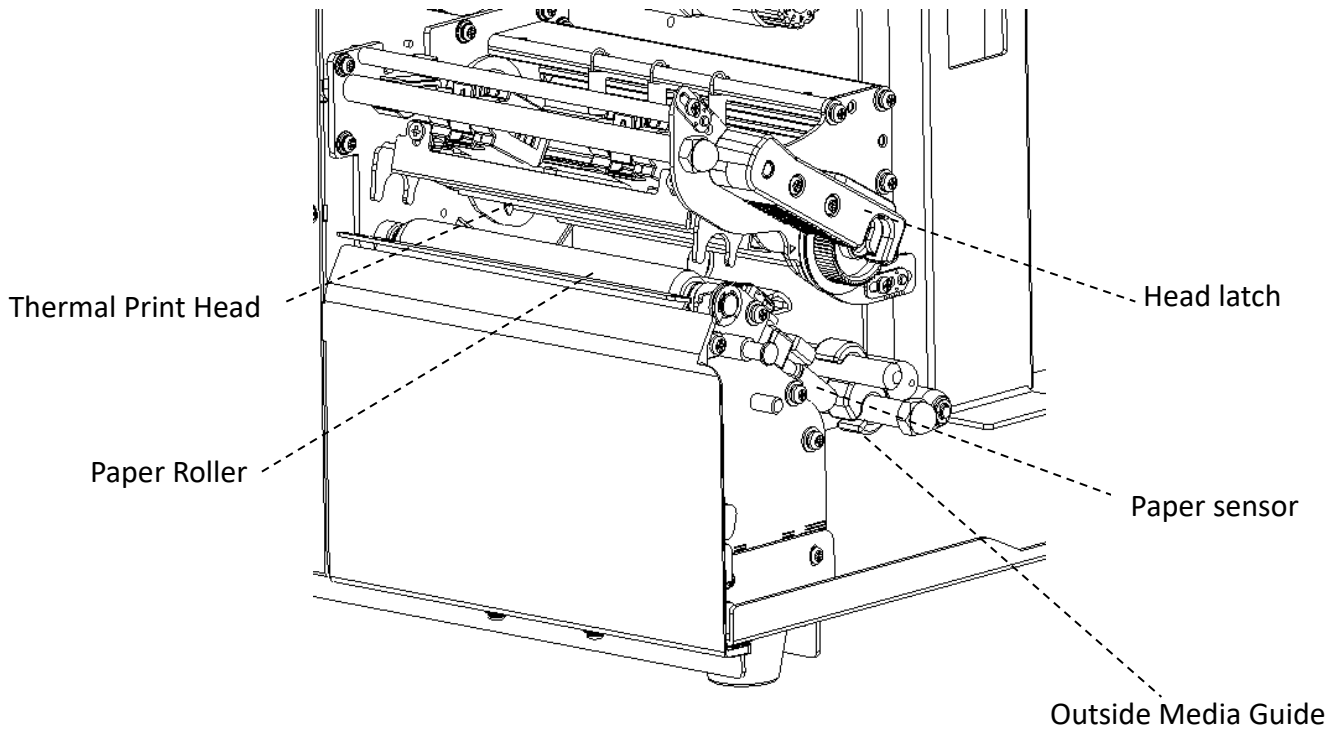

## 1.4 Printer control panel

There are three lights on the front panel - READY, MEDIA and RIBBON. These indicators display operation status of the printer. Three Buttons – FEED, PAUSE, CANCEL can control printer simple function.

### 1.4.1 Status lights

Status lights help you check printer's condition. The following tables show the status lights and the conditions they indicate.

LCD Display	READY	MEDIA	RIBBON	Description
READY	ON	ON	ON	In the ready mode
PRINT HEAD HEAT	ON	Blinking	ON	Print head needs to cool down.
COMMAND ERROR	ON	Blinking	Blinking	A command error was found while checking the command sequence.
EEPROM ERROR	ON	Blinking	Blinking	An EEPROM for back-up cannot be read/written properly.
MEMORY ERROR	ON	Blinking	Blinking	<ul style="list-style-type: none"> <li>· An error has occurred in writing data into USB memory or flash memory.</li> <li>· An erase error has occurred in formatting USB memory or flash memory.</li> <li>· Saving failed because of the insufficient capacity of USB memory or flash memory.</li> <li>· Firmware update has error.</li> </ul>
CANCEL ...	Blinking	ON	ON	Press CANCEL KEY to interrupt and delete a print task

LCD Display	READY	MEDIA	RIBBON	Description
<b>CLEAR FLASH</b>	<b>Blinking</b>	<b>ON</b>	<b>ON</b>	Clear flash memory.
<b>CUTTER FAILED</b>	<b>Blinking</b>	<b>ON</b>	<b>ON</b>	Cutter has failed, or there is paper jam inside the cutter.
<b>MEMORY FULL</b>	<b>Blinking</b>	<b>ON</b>	<b>ON</b>	Printer buffer is full caused by the loaded soft fonts, graphics or forms.
<b>MEMORY INITIALIZED</b>	<b>Blinking</b>	<b>ON</b>	<b>ON</b>	USB Memory is being initialized.
<b>PAUSE</b>	<b>Blinking</b>	<b>ON</b>	<b>ON</b>	Printer is in PAUSE status. Media sensor cannot index label gaps
<b>PRINTHEAD BROKEN</b>	<b>Blinking</b>	<b>ON</b>	<b>ON</b>	Head broken error
<b>PRINT HEAD OPEN</b>	<b>Blinking</b>	<b>ON</b>	<b>ON</b>	Head latch is not closed.
<b>RESET</b>	<b>Blinking</b>	<b>ON</b>	<b>ON</b>	Press CANCEL KEY + POWER ON to reset NVR table.
<b>SERIAL IO ERROR</b>	<b>Blinking</b>	<b>ON</b>	<b>ON</b>	The format or baud rate of the RS232 communication is inconsistent between the printer and host.
<b>SELF TEST ...</b>	<b>Blinking</b>	<b>ON</b>	<b>ON</b>	Press FEED KEY + POWER ON to print the self-test label.
<b>UPGRADING FW.</b>	<b>Blinking</b>	<b>ON</b>	<b>ON</b>	Printer is receiving data
<b>RIBBON OUT</b>	<b>Blinking</b>	<b>ON</b>	<b>Blinking</b>	Ribbon is not installed or end-of-ribbon occurred.
<b>CALIBRATION ..</b>	<b>Blinking</b>	<b>Blinking</b>	<b>ON</b>	Press PAUSE KEY + POWER ON to calibrate media.

LCD Display	READY	MEDIA	RIBBON	Description
<b>MEDIA OUT</b>	<b>Blinking</b>	<b>Blinking</b>	<b>ON</b>	Media is not installed or used up. Printer fails to detect the media gap. The media sensor is out of range during calibration. The label has run out. The last label has been issued normally and the label has run out.
<b>PAPER JAM</b>	<b>Blinking</b>	<b>Blinking</b>	<b>ON</b>	A paper jam occurred during paper feed.

## 1.4.2 Buttons

There are three buttons, each with two basic functions.

Button	Function 1	Function 2
FEED	<ul style="list-style-type: none"> <li>• Feed a label</li> </ul>	
PAUSE	<ul style="list-style-type: none"> <li>• Pause printing</li> </ul>	<ul style="list-style-type: none"> <li>• Press again to resume printing.</li> <li>• Press and hold for 2 seconds to enter the printer setup menu.</li> </ul>
CANCEL	<ul style="list-style-type: none"> <li>• Interrupt and delete a print task</li> </ul>	<ul style="list-style-type: none"> <li>• Force printer to continue after an error is solved.</li> <li>• Press and hold for 2 seconds to reboot the printer.</li> </ul>

## 2 Get started

This chapter describes how to set up your printer.

### 2.1 Attach the power cord

1. Ensure the power switch is set to the OFF position.
2. Place the printer within cable distance of the host and printer (using a USB or serial cable).
3. Keep the power cord isolated from other electrical cables.
4. Plug one end of the AC power cord into the power socket on the printer. The power socket is located on the back of the printer.
5. Plug the other end of the AC power cord into a wall outlet. Make sure the wall outlet and the printer have the same voltage and frequency, otherwise you may damage or explode the printer.

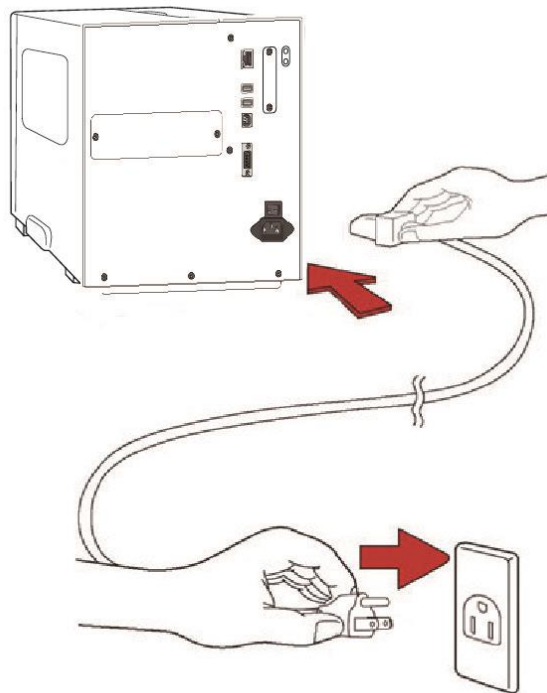

**Warning** Do not plug the AC power cord with wet hands, or operate the printer and the power supply in an area where they may get wet. Serious injury may result from these actions!

## 2.2 Turn on/off your printer

When your printer is connected to a host (a computer), it is good to turn on the printer before turning on the host and turn off the host before turning off the printer.

### 2.2.1 Turn on your printer

1. To turn on your printer, turn on the **Power Switch** as below. The “I” is the **ON** position.

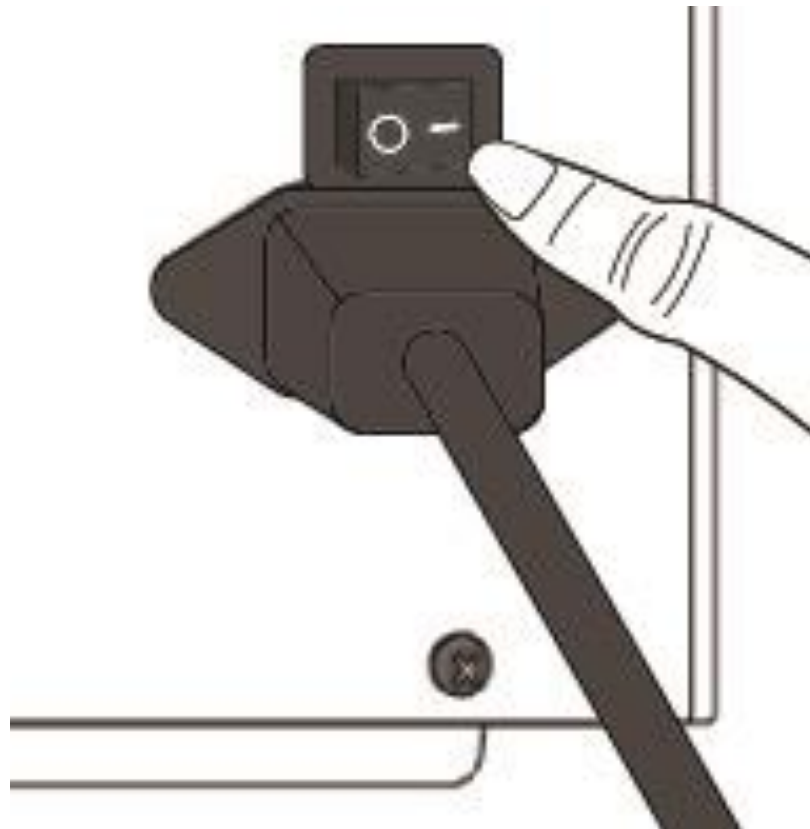

2. READY, MEDIA, and RIBBON LED stay solid blue. Then the READY LED will turn off for a few seconds while the LCD screen displays the firmware version. The LCD will display Ready to Print and the READY LED will return to solid blue.

## 2.2.2 Turn off your printer

1. Make sure READY 、 MEDIA 、 RIBBON stay solid blue before turning off the printer.
2. To turn off your printer, turn off the **Power Switch** as below. The “O” is the **OFF** position.

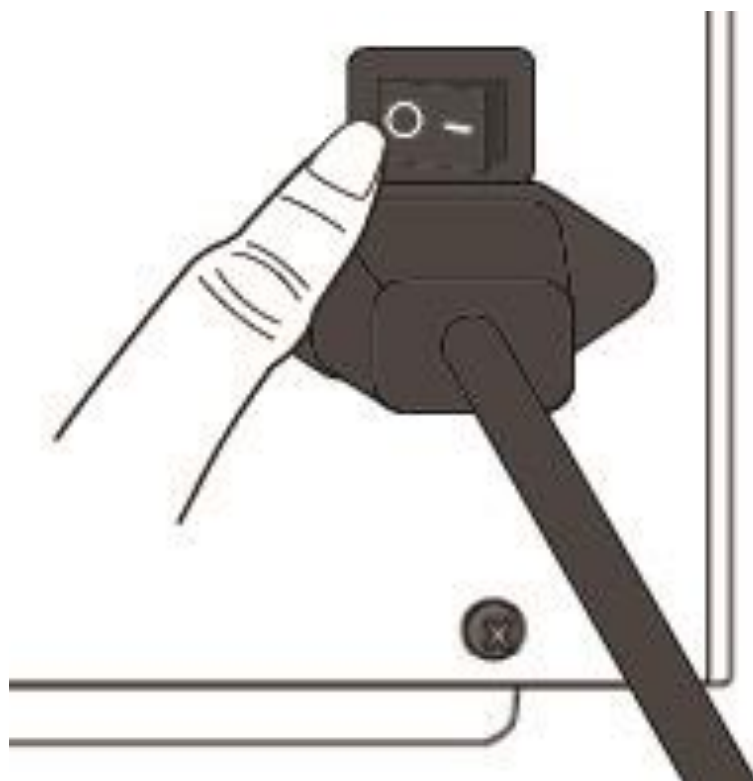

**Caution** Do not turn off the printer during data transfer.



## 2.3 Load media

The XM4 Series printers offer three different loading modes: standard, peel-off, or with a cutter.

- **Standard mode** allows you to collect each label freely.
- **Peel-off mode** peels the liner away from the label as it is printed. After the label is removed, the next label is printed.
- **Cutter mode** automatically cuts the label after it is printed. There are rotary cutter and guillotine cutter types for cutting media.

### Thermal Transfer Media Loading Instructions

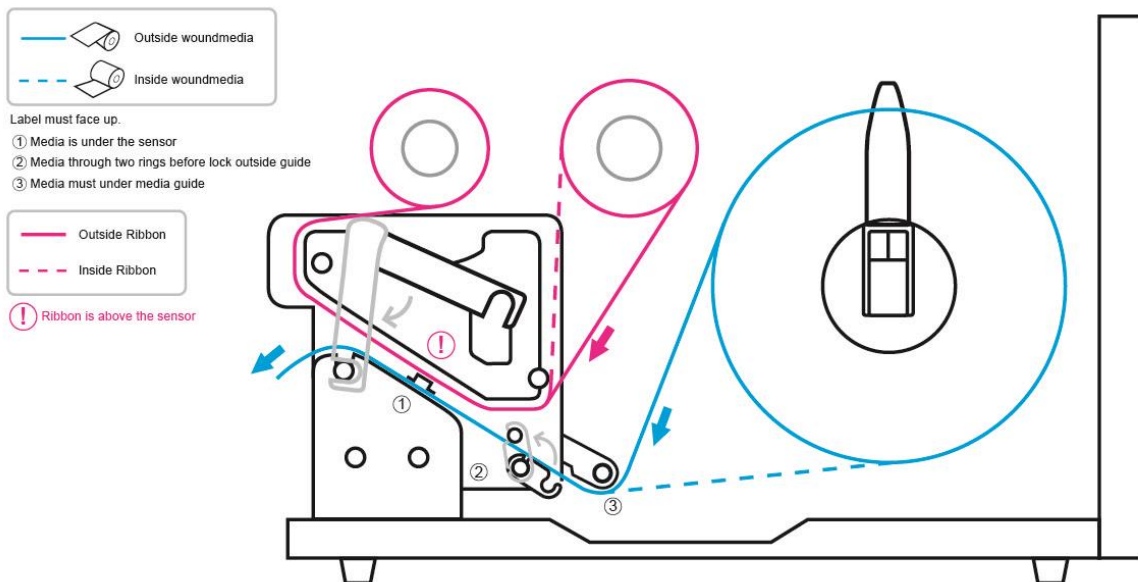

## 2.3.1 Prepare media

The media roll can be loaded into the printer in the same manner for both inside and outside wound media. In case the media roll is dirty during shipping, handling, or storage, remove the outer length of the media. It helps avoid dragging adhesive and dirty media between the printhead and platen roller.

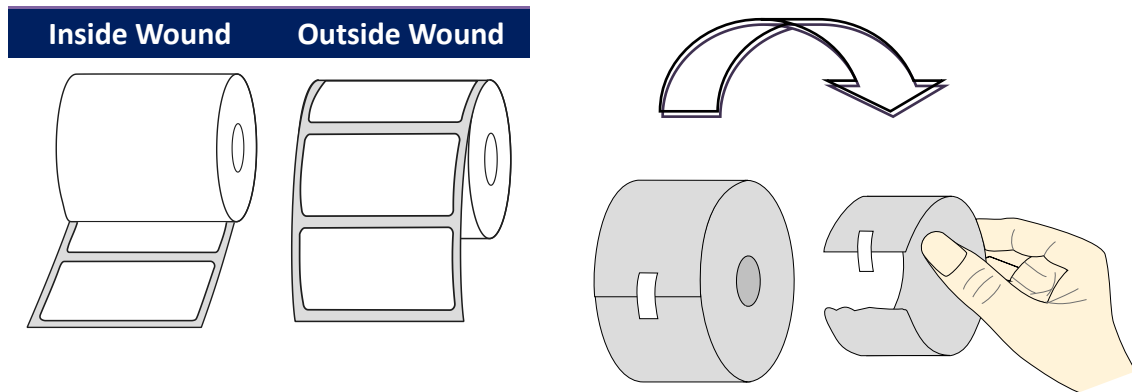

## 2.3.2 Placing media roll

### Load Media In Standard Mode

- 1 Lift the top cover to expose the media compartment.

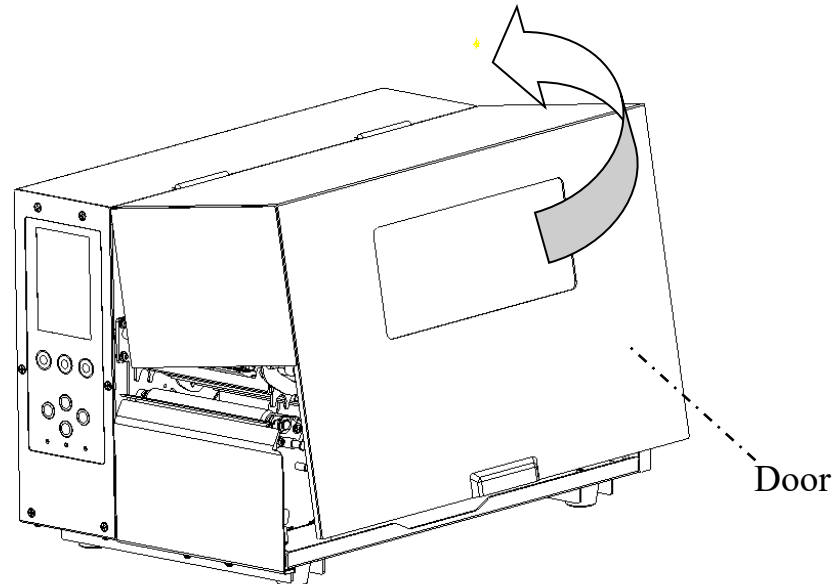

- 2 Insert the media roll into the media supply spindle and slide the media guide inward.

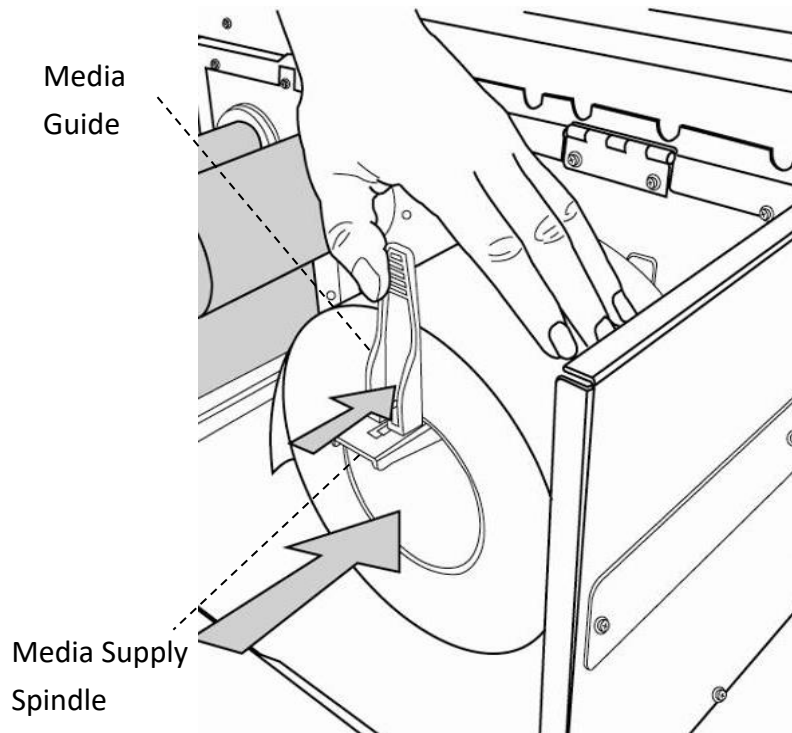

3. Rotate the head latch counterclockwise and open the outside media guide counterclockwise for media loading.

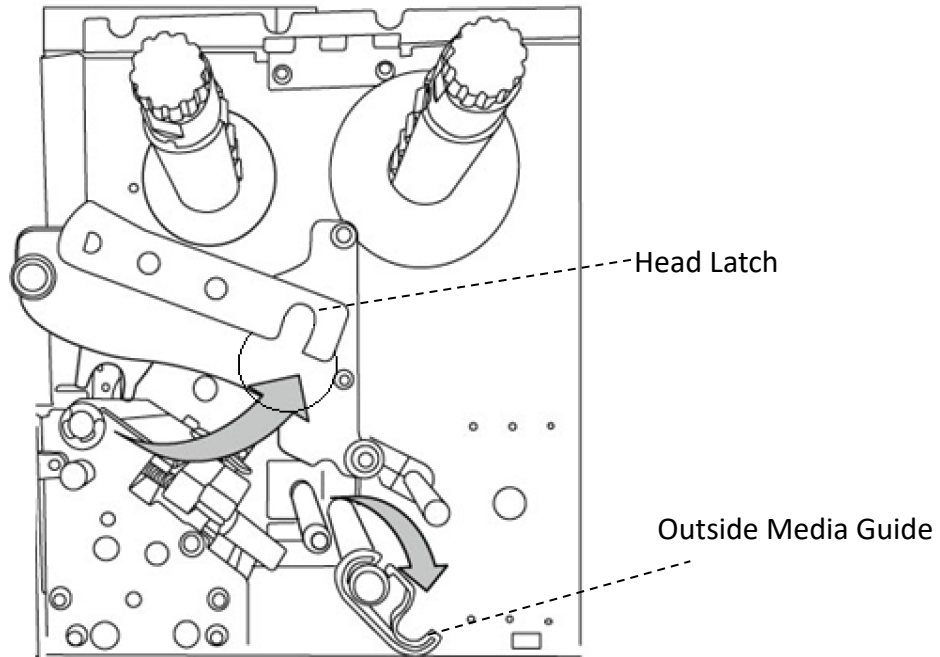

4. The label must face up as the media passes through the printhead module. Thread the media under the 'media guide' and through two rings until it locks in place at the 'Outside Media Guide'. Then, pass it under the paper sensor guide module and over the roller.

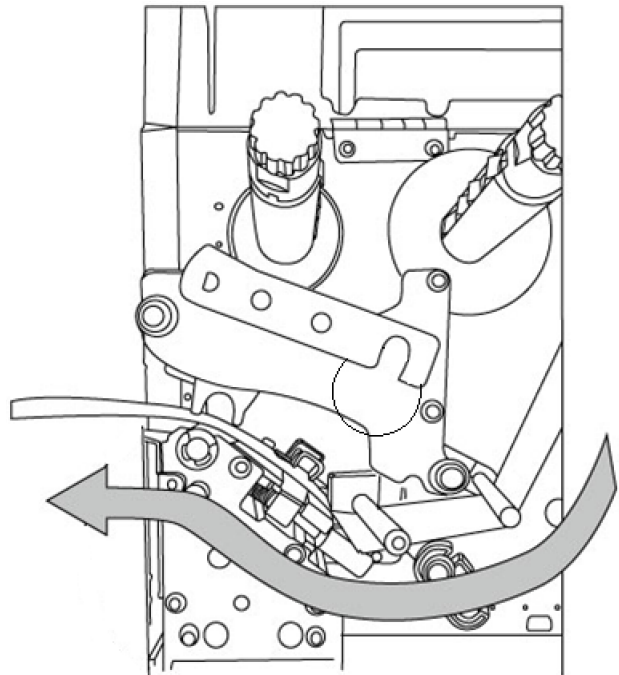

5. Return the outside media guide and hook the head latch.

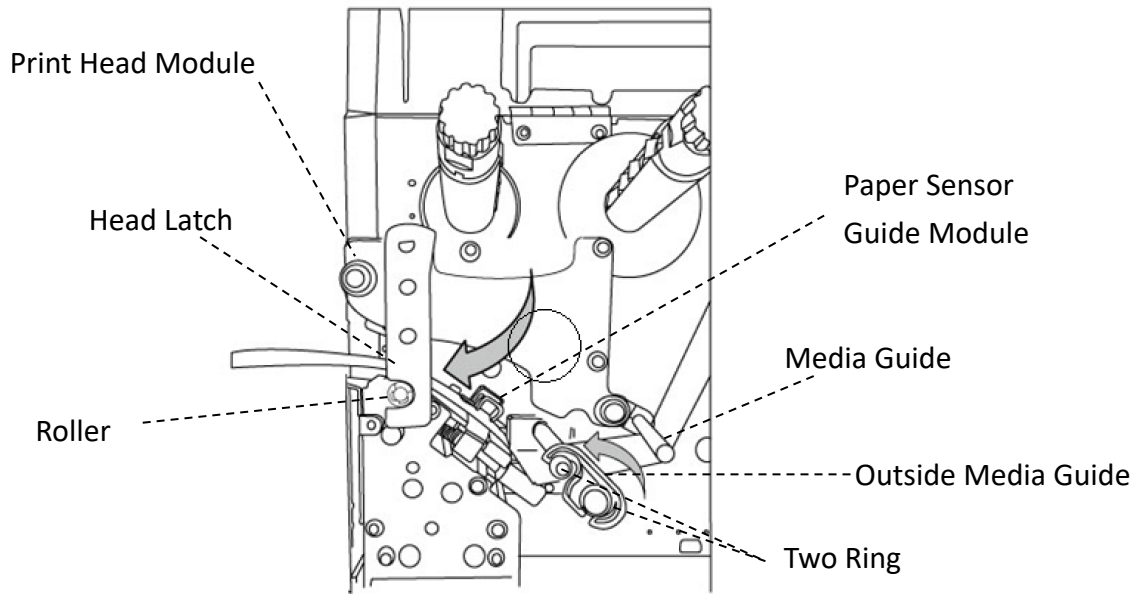

6. Close the top cover.

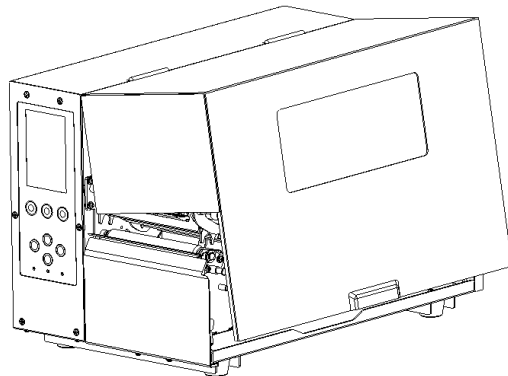

7. Press the FEED button if the printer is already on.

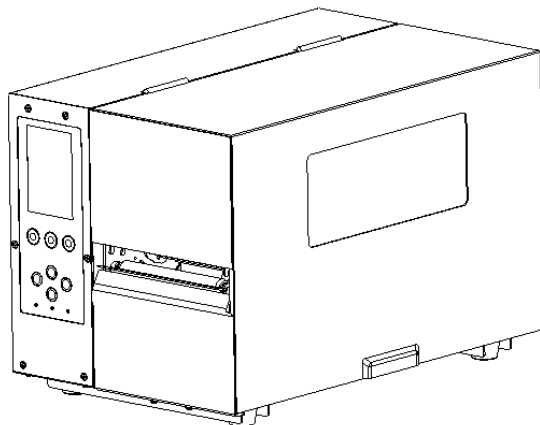

**Note** Make sure the label length of the die-cut media is at least 25 mm (1") or longer for direct thermal printing in tear-off mode with perforation.



**Important** After the media is loaded, please perform media calibration to calibrate the label sensor before printing.

## Load Media in Peel Off Mode

Steps 1 to 3 are the similar to “Standard Mode”.

1. Lift the top cover to expose the media compartment.
2. Load a roll of media into the media supply spindle and slide the media guide inward.
3. Rotate the head latch counterclockwise and open the outside media guide for media loading.
4. Remove enough labels from the leading end of the media roll to expose 6 inches of liner.

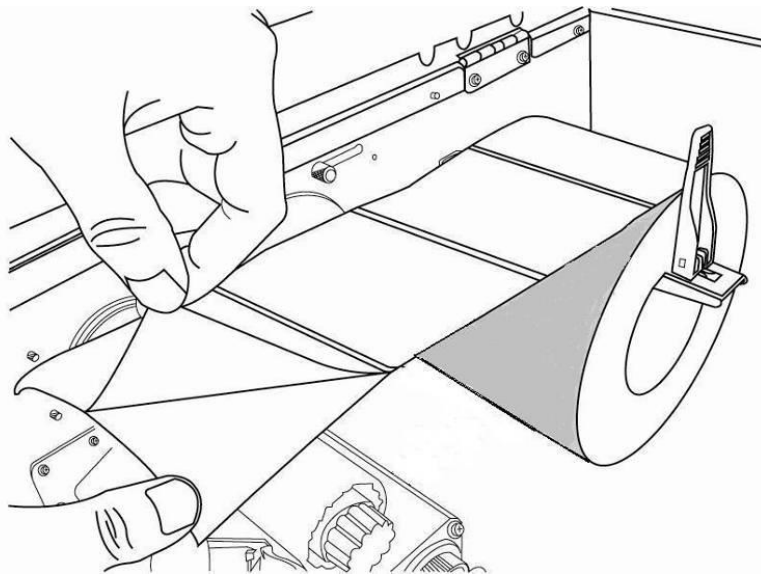

5. Guide the media liner under the printhead module. For more specific media guidance, refer to Step 4 in Standard Mode.

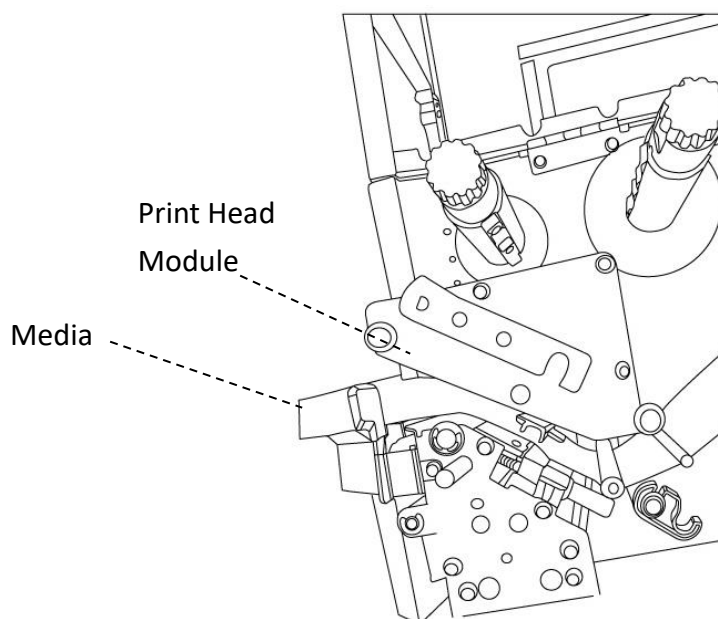

6. Push down the peel-off mechanism release lever and guide the media liner behind the dispenser (peeler) module.

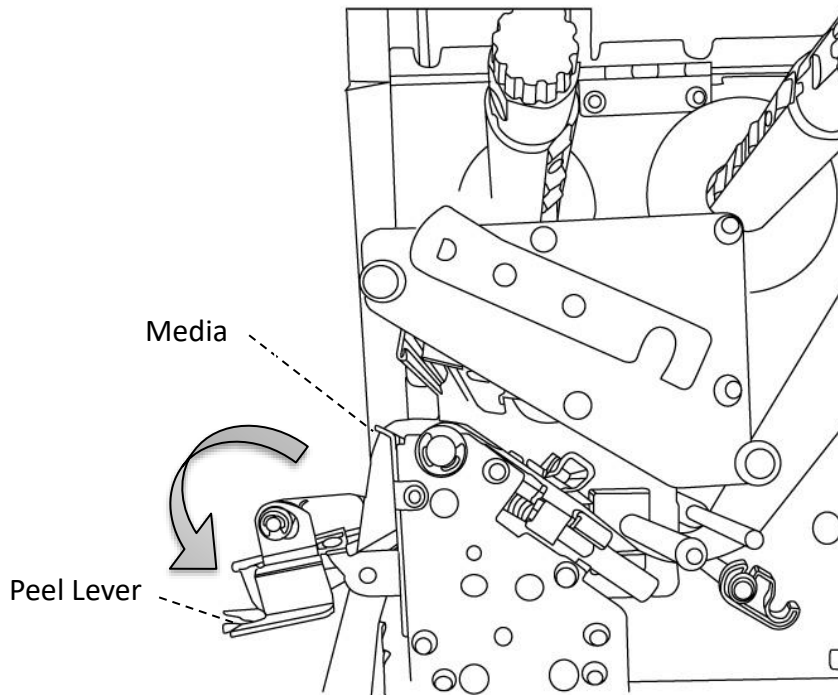

7. Close the dispenser (peeler) module using the peel-off mechanism release lever. Return the outside media guide and hook the head latch.

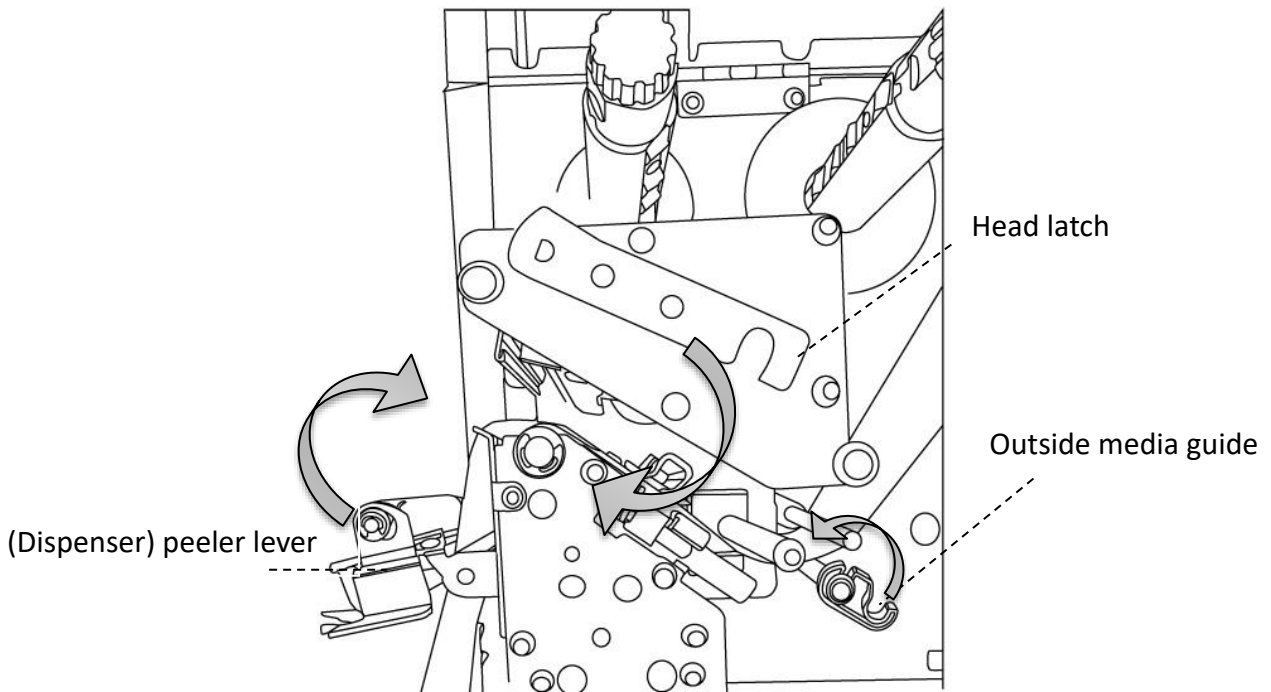

8. Close the top cover and turn on the printer or, press the FEED button if the printer is already on.

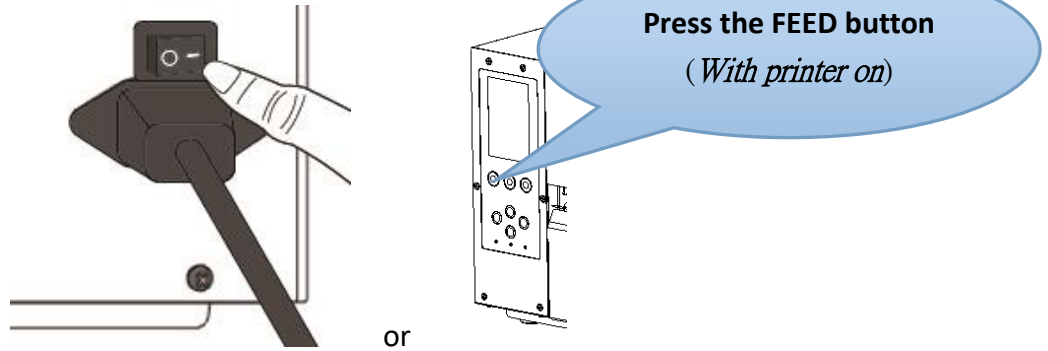

---

***Important***



After the media is loaded, please perform media calibration to calibrate the label sensor before printing.

---



## Load Media in Rotary Cutter Mode

Steps 1 to 3 are the similar to “Standard Mode”.

1. Lift the top cover to expose the media compartment.
2. Load a roll of media into the media supply spindle and slide the media guide inward.
3. Rotate the head latch counterclockwise and turn on the outside media guide.
4. Load the media roll under the print head module and under the paper sensor guide over the roller. For more specific lead media, see Step 4 in Standard Mode.

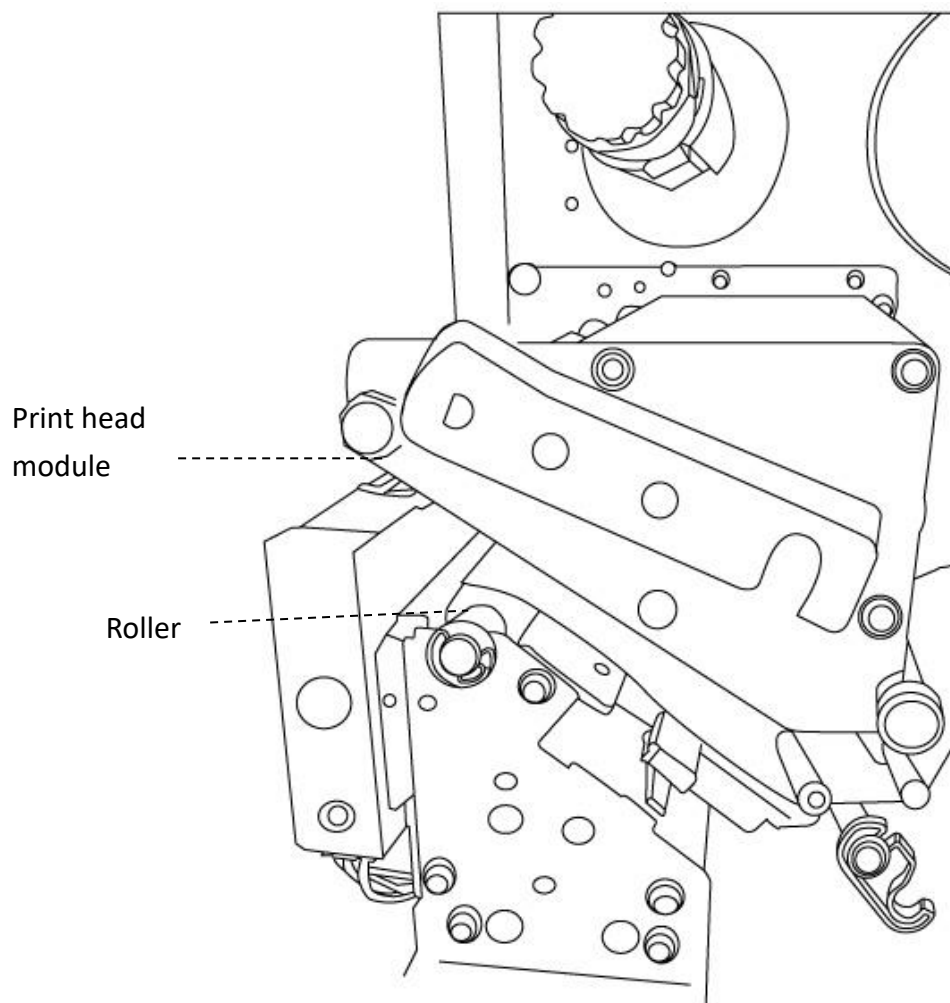

5. Return the outside media guide and hook the head latch.

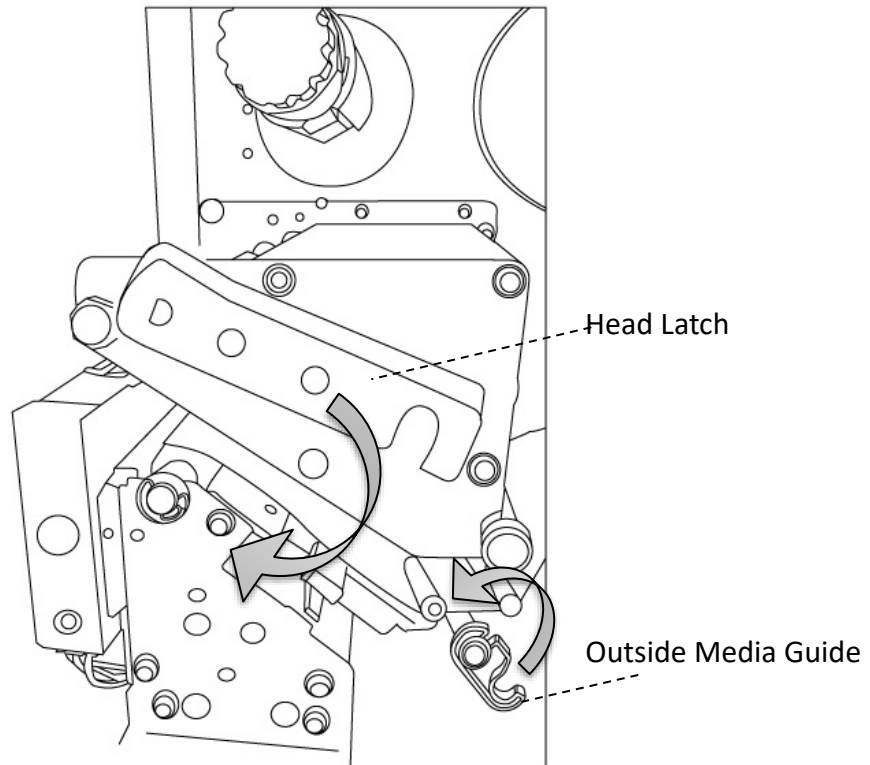

6. Close the top cover and turn on the printer or, press the FEED button if the printer is already on. The printer will then feed the labels through the cutter automatically.

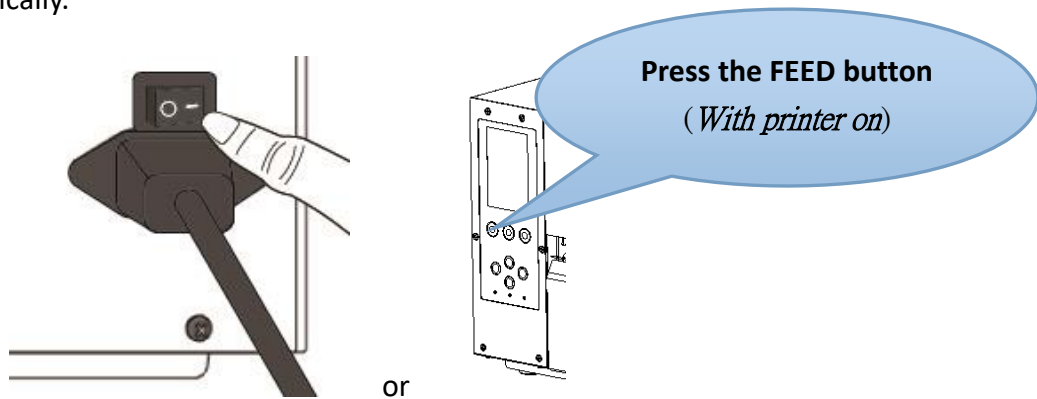

---

**Important**



After the media is loaded, please perform media calibration to calibrate the label sensor before printing.

---

## Load Media in Guillotine Cutter Mode

Steps 1 to 3 are the similar to “Standard Mode”.

1. Lift the top cover to expose the media compartment.
2. Load a roll of media into the media supply spindle and slide the media guide inward.
3. Rotate the head latch counterclockwise and turn on the outside media guide.
4. Load the media roll into the printhead module and under the paper sensor guide. For more specific lead media, see Step 4 in Standard Mode. Unhook the cutter module and pull the down mechanism release lever from the cutter and feed media through the cutter.

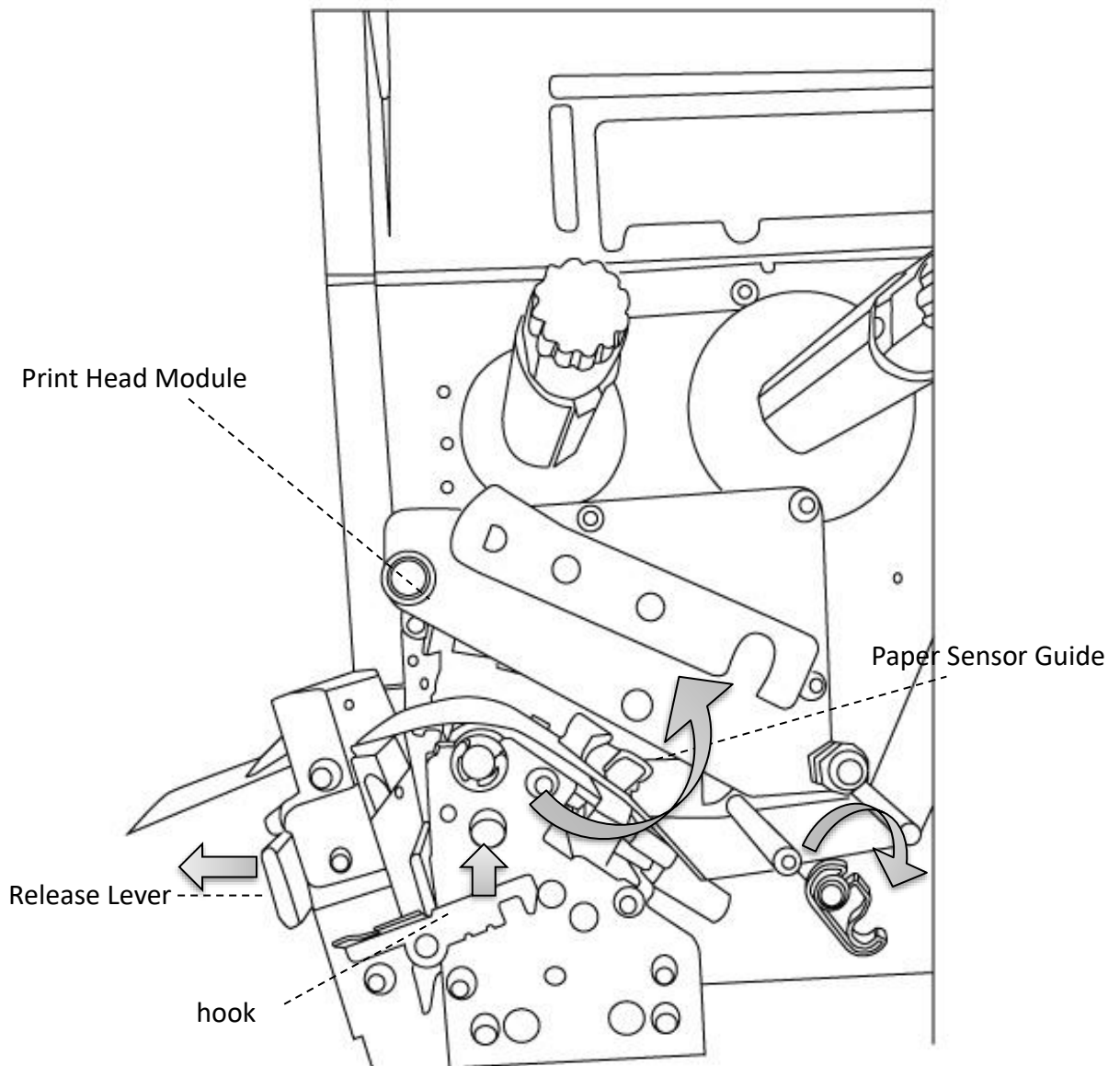

5. Retract the guillotine cutter, retract the outside media guide, and hook the head latch.

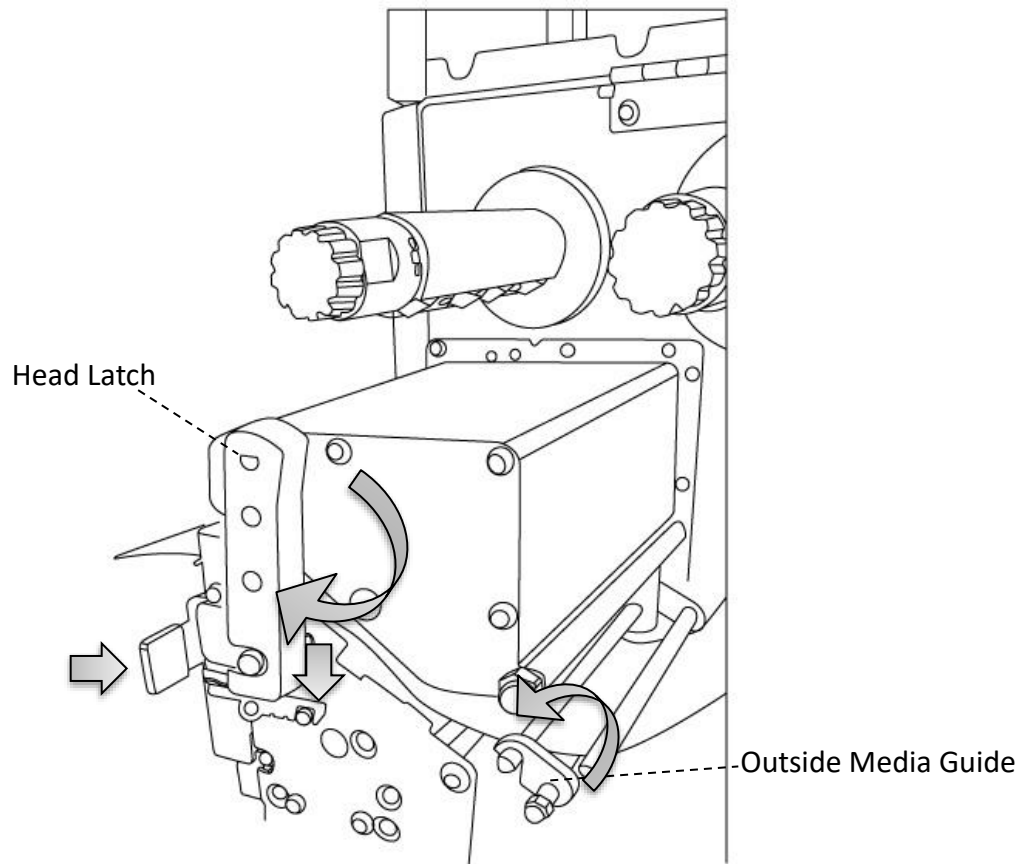

6. Close the top cover and turn on the printer or, press the FEED button if the printer is already on. The printer will then feed the labels through the cutter automatically.

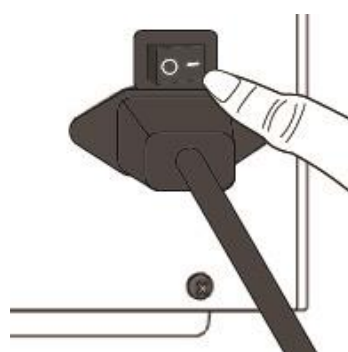

or

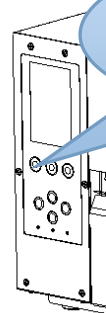

**Press the FEED button**  
(*With printer on*)



***Important***

After the media is loaded, please perform media calibration to calibrate the label sensor before printing.

## 2.3.3 Media types

Your printer supports various media types, including non-continuous media, continuous media, and fanfold media. The following table provides details about them.

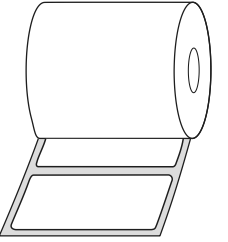
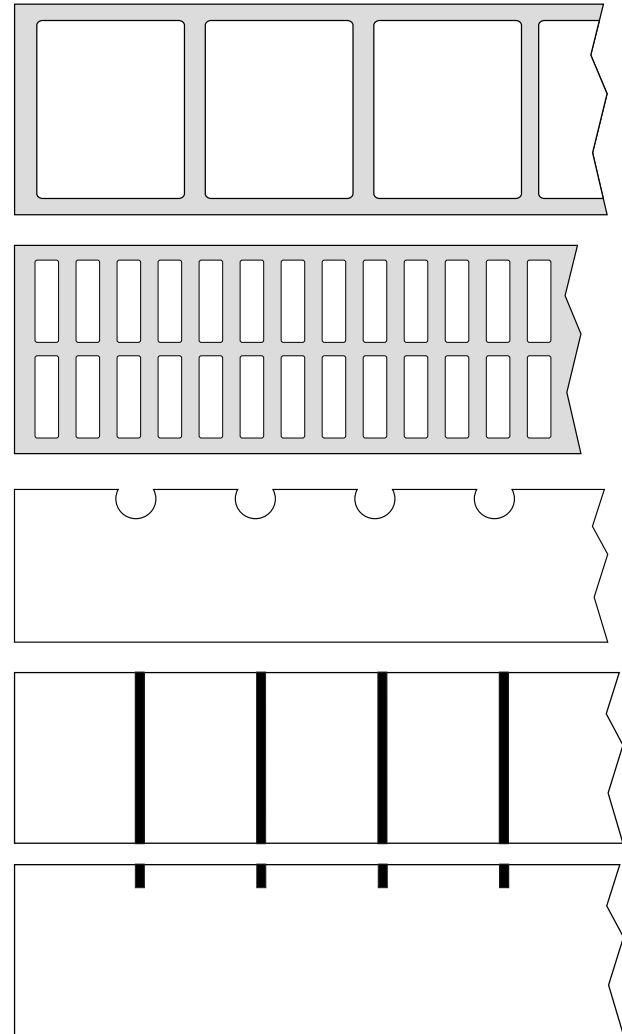
Media Type	Looks Like	Description
<p><b>Non-Continuous Media</b></p>		<p>Non-continuous media is the typical media for bar code printing. Labels and tags are made of various materials, such as paper, fabric or cardstock, and are separated by gaps, holes, notches or black marks. Many labels are self-adhesive with liners, while some are linerless.</p> 

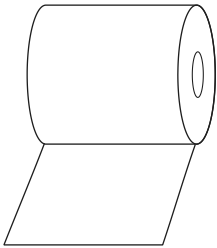
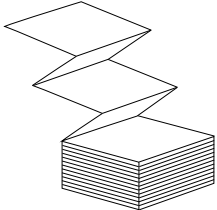
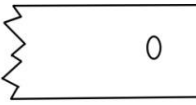
Media Type	Looks Like	Description
<b>Continuous Media</b>		Continuous media does not have gaps, holes, notches or black marks. It allows you to print data anywhere on the media. A cutter may be used for splitting labels. Mostly it is used for direct thermal printing.
<b>Fanfold Media</b>		Fanfold media is in continuous form, but it can be used as non-continuous media, because its labels are separated by folds. Some fanfold media also has black marks or liners.
<b>Tag Media</b>		Tag media is usually made from a heavy paper, with center hole to index. It does not have adhesive or a liner, and it is typically perforated between tags. The media may also have black marks or other separations.

## 2.4 Load Ribbon

The following steps only apply to thermal transfer printing mode.

Direct thermal does not need ribbon to be installed.

XM4 Series printers apply to both Inside wound ribbon and Outside wound ribbon.

Printers can switch automatically.



### Note

- Media and ribbon types should be matched to provide with optimal print results.
- Always use ribbon that is wider than the media to protect the print head from wear.

## 2.4.1 Placing Ribbon Roll

1. Lift the top cover to expose the media compartment.

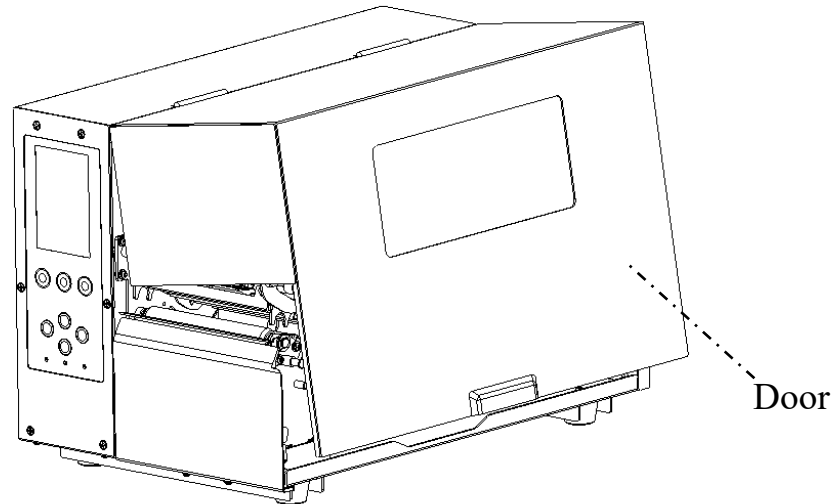

2. Rotate the head latch counterclockwise.

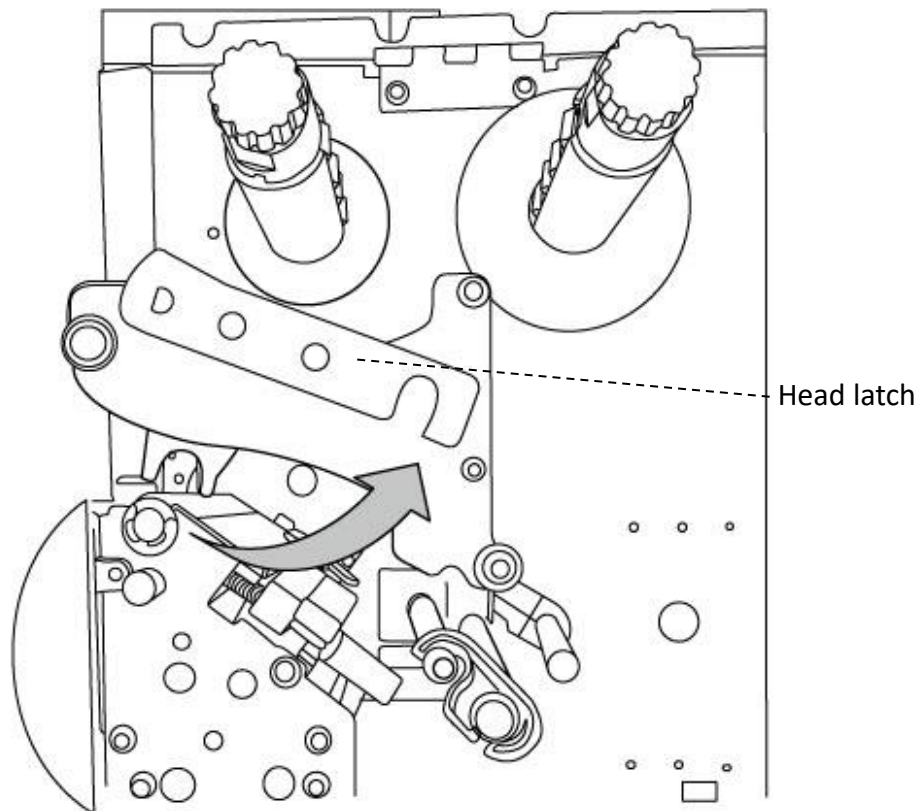



3. Unwrap the ribbon and separate the ribbon roll from the bare core. Load the ribbon roll onto the ribbon supply spindle.

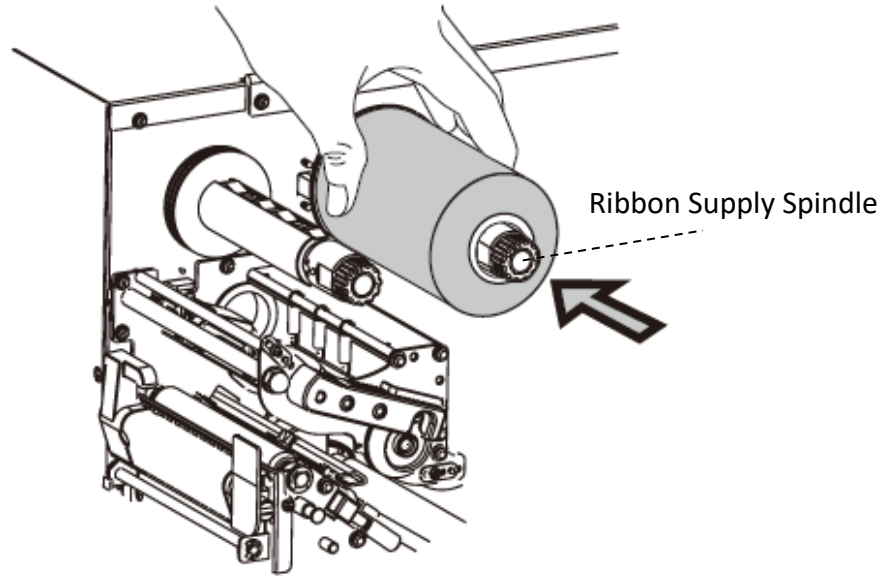

4. Thread the ribbon through the print head module. Place the edge of the ribbon on the bare core and wind a little onto the core. Make sure the coating side of the ribbon is facing down.

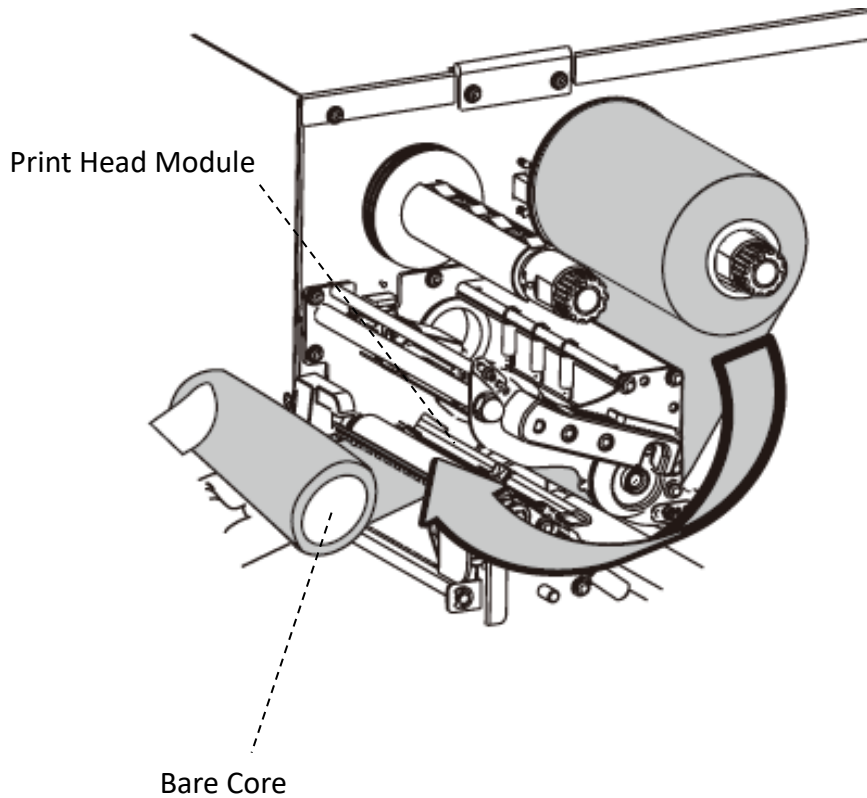

5. Slide the core onto the ribbon pick-up spindle. Rotate the spindle to ensure that the ribbon is wound tightly.

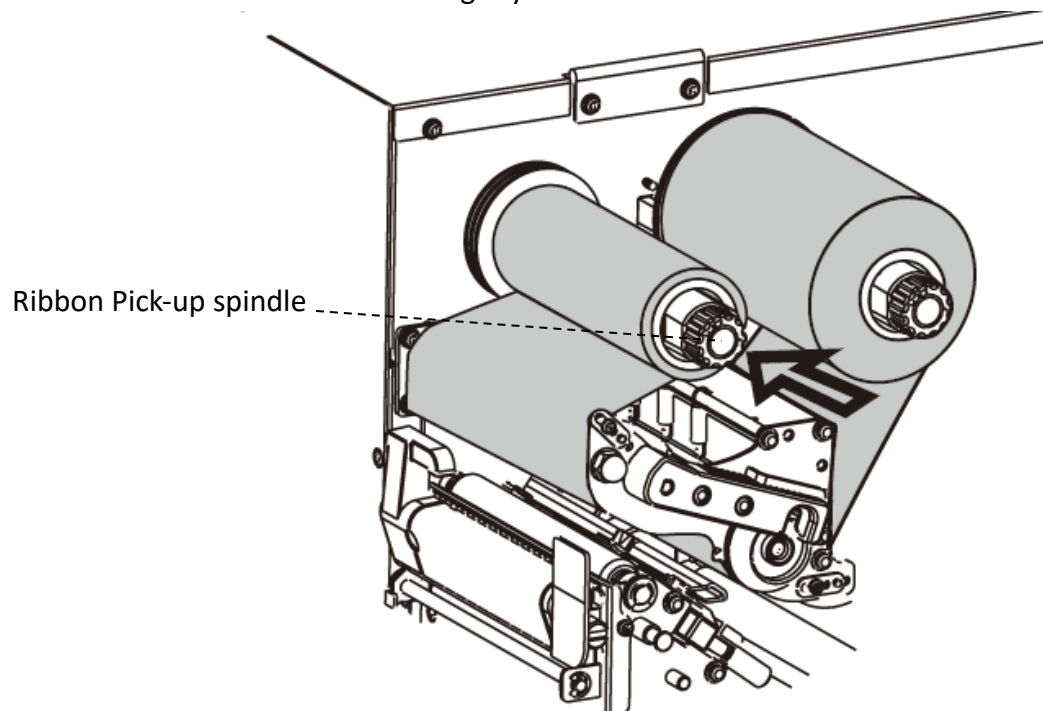

6. Close the top cover and turn on the printer.

## 3 Printer operation

This chapter provides more specific information about printer operation.

### 3.1 Front Panel

Change settings using panel buttons:

Button	Function
Menu key (PAUSE)	Press and hold for 2 seconds to enter menu setting mode.
Back key (FEED)	Return to the top level of the setup page or exit the menu setup mode.
Enter key (Cancel)	Select the next level of menu items or save a parameter in the permanent FLASH memory.
Up / Down / Left / Right	Navigation key, for changing a selected item or value of item setting. Active only in Menu mode.



**Warning** *Do not change settings while printing or sending print data.*

## 3.2 LCD Function Setting Procedure

The following procedure is an example of setting procedure to direct thermal printing mode:

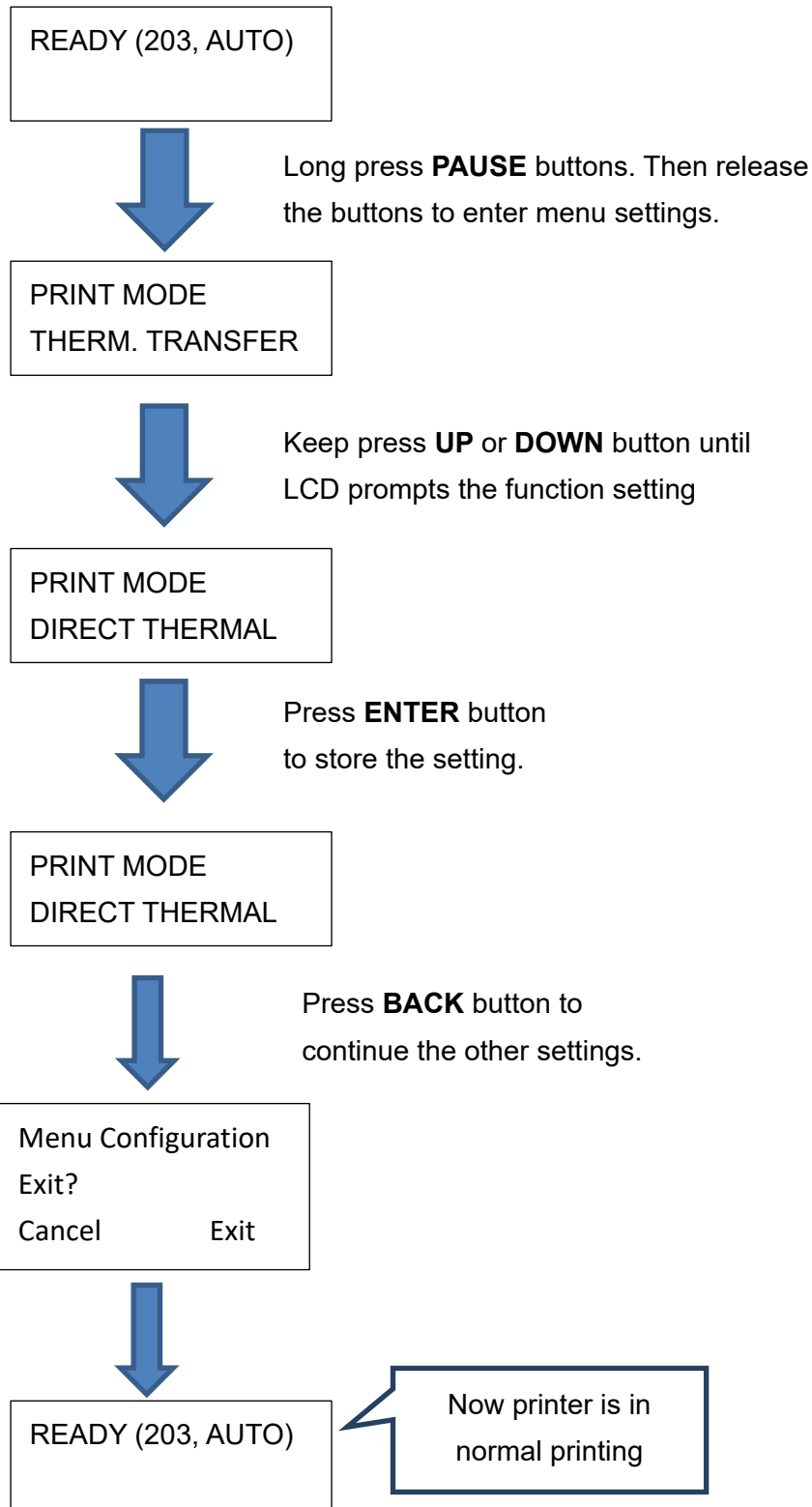

## 3.3 Control / Navigation Buttons

This section of the manual provides information on the control and navigation buttons located on the printer's control panel. The diagram on this page shows the location and function of each button.

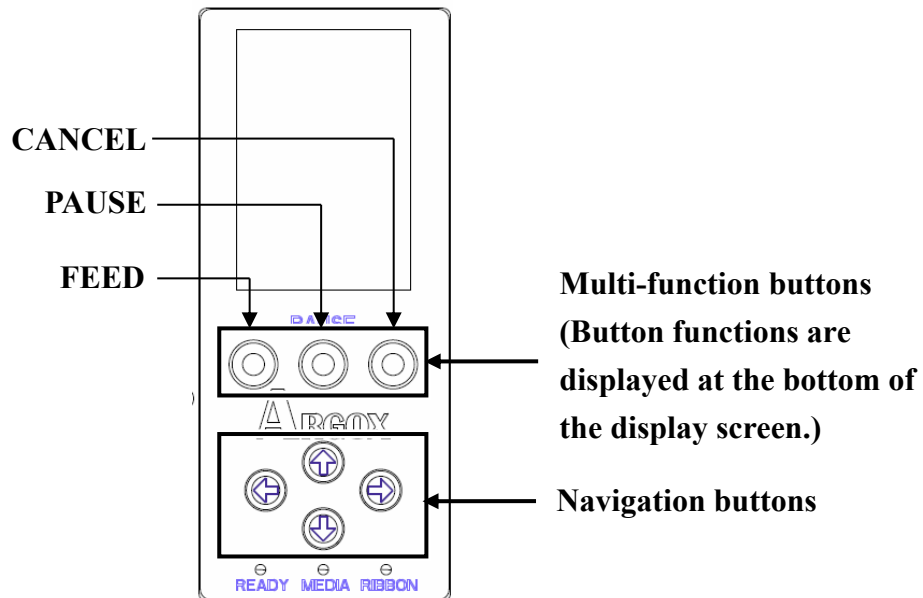

Press and hold the **PAUSE** button over 2 seconds on the control panel to enter the printer setup menu.

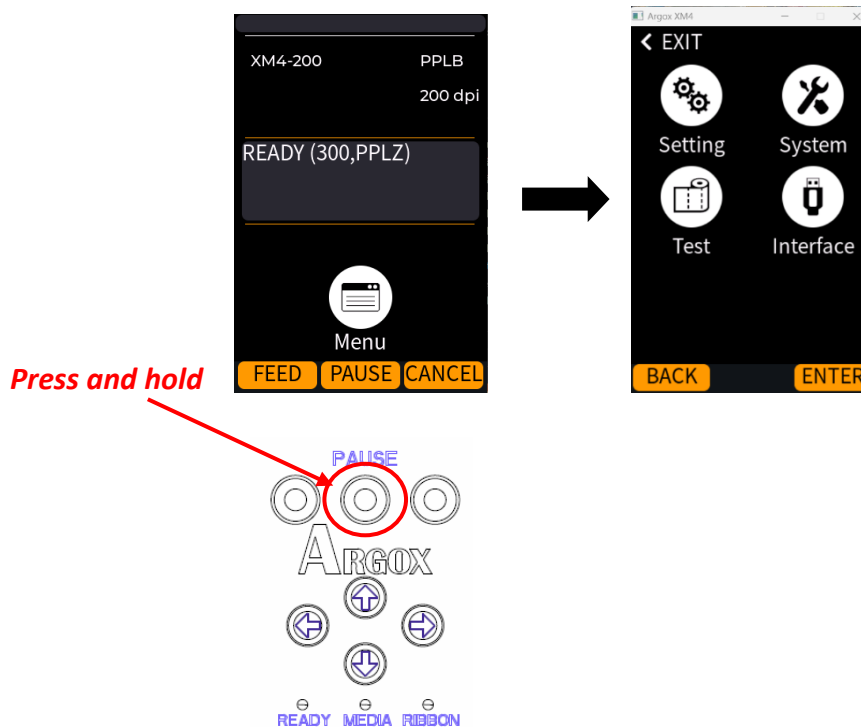

## 3.4 Printer Setup Menu

There are four main setup options in the printer setup menu, **Setting**, **System**, **Test**, and **Interface**. On the printer setup menu screen, press the navigation button on the control panel to navigate to the option to be set, which will appear in orange. After that, press the button below Enter shown on the screen to enter the setup sub-menu.

The following is a summary list of all setting items of each of the main setup options.

### ➤ Settings

Item	No.	Sub Item
Setting		
Print		
	1	PRINT MODE
	2	SPEED
	3	DARKNESS(0-30)
	4	TPH VER OFFSET
	5	BACK FEED
	6	BACK DISTANCE
	7	CUTTER INSTALLED
	8	CUT MODE
	9	CUT PEEL OFFSET
	10	PEELER INSTALLED

Item	No.	Sub Item
Setting		
Advance		
	11	MEDIASENSOR TYPE
	12	CALIBRATION MODE
	13	CONTROL CODE SET
	14	STANDALINE MODE
	15	COUNTING
	16	RECOVER PRINT
	17	WIN.CON.LEN.

### ➤ System

Item	No.	Sub Item
System		
	18	Language
	19	CLEAR FLASH
	20	SETTING PRIORITY
	21	STANDBY
	22	EMULATION
	23	BUZZER
	24	LOAD DEFAULT

➤ **Test**

Item	No.	Sub Item
Test		
	25	Print Self Test
	26	Media Calibration
	27	Cut Action

➤ **Interface**

Item	No.	Sub Item
Interface		
COM RS-232		
	28	BAUD RATE
	29	PARITY(RS232)
	30	LENGTH(RS232)

### 3.4.1 Settings

The following detailed settings of the printer are **Print** and **Advance**.

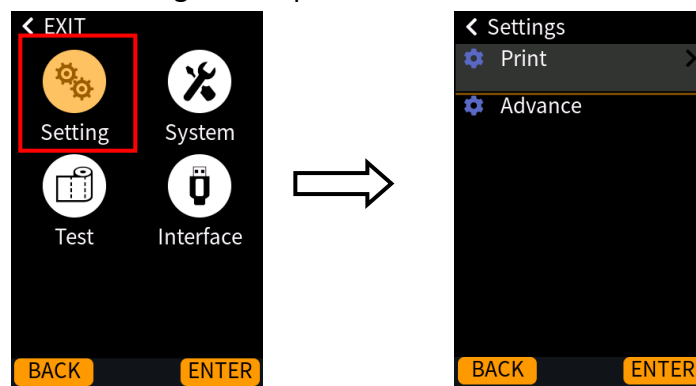

➤ **Print**

Item	No.	Sub Item	Value	Enter key	Select Key	Back Key
Setting				Enter/Right	Up/Down	Back/Left
Print				Enter/Right	Up/Down	Back/Left
	1	PRINT MODE		Enter/Right	Up/Down	Back/Left
			DIRECT THERMAL	Enter/Right	Left/Right	Back
			THERRM. TRANSFER			

**Factory Default: THERRM. TRANSFER**

**Remark: Restart printer after changing the settings.**

Item	No. Sub Item	Value	Enter key	Select Key	Back Key
	2	SPEED	Enter/Right	Up/Down	Back/Left
		2 ~ 12 IPS(XM4-250)	Enter/Right	Left/Right	Back
		2 ~ 12 IPS(XM4-350)			
Factory Default: 6 IPS (XM4-250) / 5 IPS (XM4-350)					
	3	DARKNESS(0-30)	Enter/Right	Up/Down	Back/Left
		0 ~ 30	Enter/Right	Left/Right	Back
Factory Default: 16					
	4	TPH VER OFFSET	Enter/Right	Up/Down	Back/Left
		-9 ~ 9 mm	Enter/Right	Left/Right	Back
Factory Default: 0 mm					
Remark: To adjust the offset of vertical print position					
	5	BACK FEED	Enter/Right	Up/Down	Back/Left
		DISABLE	Enter	Enter	Back
		ENABLE			
Factory Default: ENABLE					
Remark: Available only in PPLA and PPLB printer languages. Once "ENABLE" is selected, the printer enters BACK DISTANCE setting.					
	6	BACK DISTANCE	Enter/Right	Up/Down	Back/Left
		10 ~ 40 mm	Enter/Right	Left/Right	Back
Factory Default: 22 mm					
Remark: Available only when BACK FEED is enabled					
	7	CUTTER INSTALLED	Enter/Right	Up/Down	Back/Left
		NO	Enter/Right	Left/Right	Back
		YES			
Factory Default: NO					
Remark: Restart printer after changing the setting					
	8	CUT MODE	Enter/Right	Up/Down	Back/Left
		NORMAL	Enter/Right	Left/Right	Back
		CUT W/O BACK 1			
		CUT W/O BACK 2			
	9	CUT PEEL OFFSET	Enter/Right	Up/Down	Back/Left
		-15 ~ 15 mm	Enter/Right	Left/Right	Back
Factory Default: 0 mm					
Remark: To adjust cut and peel positions					



Item	No.	Sub Item	Value	Enter key	Select Key	Back Key
	10	PEELER INSTALLED		Enter/Right	Up/Down	Back/Left
			NO	Enter	Enter	Back
			YES			

Factory Default: NO

➤ Advance

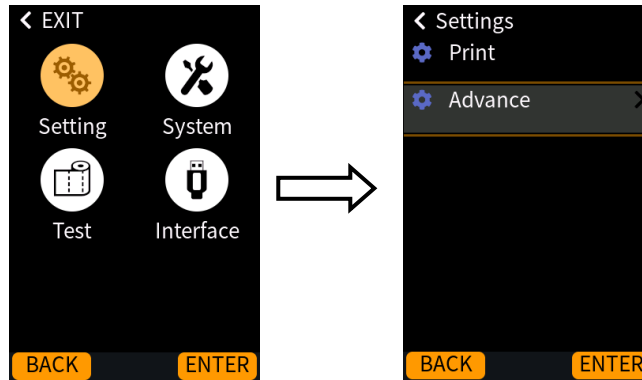

Item	No.	Sub Item	Value	Enter key	Select Key	Back Key
Setting				Enter/Right	Up/Down	Back/Left
Advance				Enter/Right	Up/Down	Back/Left
	11	MEDIASENSOR TYPE		Enter/Right	Up/Down	Back/Left
			REFLECTIVE	Enter/Right	Left/Right	Back
			SEE-THROUGH			

Factory Default: SEE-THROUGH

Remark: To select for different media types. after changing the sensor setting, make sure to calibrate before printing. (Restart printer after changing the settings.)

	12	CALIBRATION MODE		Enter/Right	Up/Down	Back/Left
			INTELLI PRINT			
			SMART PRINT	Enter/Right	Left/Right	Back
			MANUAL PRINT			

Factory Default: INTELLI PRINT

Remark: In INTELLI PRINT mode, just install labels, latch print module, press the FEED button once, and then the printer will feed 1-2 labels to detect next gap / black mark before printing. In SMART PRINT mode, print immediately from the first label according to the label length setting. Make sure to carefully align label bottom edge at the tear-off position before printing. Restart printer after changing the settings.

13	CONTROL CODE SET		Enter/Right	Up/Down	Back/Left
		STANDARD			
		ALTERNATIVE 1	Enter/Right	Left/Right	Back
		ALTERNATIVE 2			
		ALTERNATIVE 3			

**Factory Default: STANDARD**

**Remark: Available in only PPLA printer language. Restart printer after changing the settings.**

14	STANDALONE MODE		Enter/Right	Up/Down	Back/Left
		NO			
		YES			

**Factory Default: NO**

**Remark: Available in only PPLB printer language. Restart printer after changing the setting.**

15	COUNTING		Enter/Right	Up/Down	Back/Left
		DOWN	Enter/Right	Left/Right	Back
		UP			

**Factory Default: DOWN**

16	RECOVER PRINT		Enter/Right	Up/Down	Back/Left
		DISABLE	Enter	Enter	Back
		ENABLE			

**Factory Default: ENABLE**

**Remark: There will be no reprint after recovery from a media out or ribbon out error.**

17	WIN.CON.LEN.		Enter/Right	Up/Down	Back/Left
		0 ~ 254 mm	Enter/Right	Left/Right	Back

**Factory Default: 0 mm**

**Remark: Available only in Windows with bundled printer driver and for continuous media**

### 3.4.2 System

The following detailed settings of the printer are **Language, Clear Flash, Setting Priority, Standby, Emulation, Buzzer, and Load Default.**

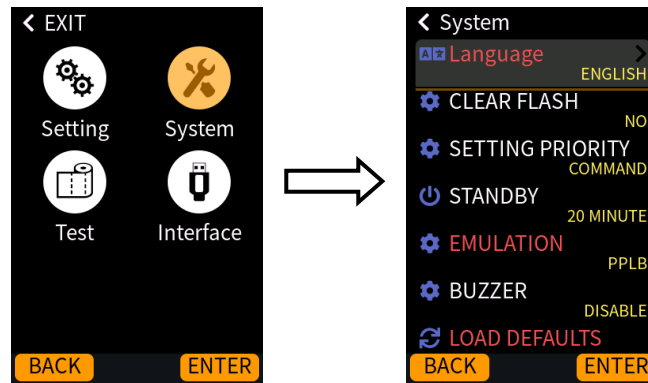

#### ➤ Language

Item	No.	Sub Item	Value	Enter key	Select Key	Back Key
System				Enter/Right	Up/Down	Back/Left
	18	Language		Enter/Right	Up/Down	Back/Left
			English 简体中文 繁體中文	Enter/Right	Left/Right	Back

**Factory Default: English**

**Remark: Restart printer after changing the setting.**

	19	CLEAR FLASH		Enter/Right	Up/Down	Back/Left
			NO YES	Enter	Enter	Back

**Factory Default: NO**

**Remark: When “YES” is selected, all the label forms, soft fonts, and graphics stored will be deleted. Restart printer after changing the setting.**

	20	SETTING PRIORITY		Enter/Right	Up/Down	Back/Left
			COMMAND LCD PANEL	Enter/Right	Left/Right	Back

**Factory Default: COMMAND**

**Remark: Choosing priority of LCD settings. It decides which setting method - command or LCD panel - takes precedence.**

21	STANDBY		Enter/Right	Up/Down	Back/Left
		DISABLE			
		1 MINUTE			
		2 MINUTE			
		5 MINUTE	Enter/Right	Left/Right	Back
		10 MINUTE			
		20 MINUTE			
		30 MINUTE			

**Factory Default: DISABLE**

22	EMULATION		Enter/Right	Up/Down	Back/Left
		AUTO			
		PPLA			
		PPLB	Enter/Right	Left/Right	Back
		PPLZ			

**Factory Default: AUTO**

**Remark: Restart printer after changing the setting.**

23	BUZZER		Enter/Right	Up/Down	Back/Left
		DISABLE			
		ENABLE	Enter	Enter	Back

**Factory Default: ENABLE**

24	LOAD DEFAULT		Enter/Right	Up/Down	Back/Left
		LAST SAVED			
		FACTORY	Enter/Right	Left/Right	Back
		NETWORK			

**Factory Default: LAST SAVED**

**Remark: Restart printer after changing the setting.**

**LAST SAVED: NO.1~15, NO.17, NO.22, NO.24~25 and language will be loaded.**

**FACTORY: NO.1, NO6, NO9, NO11, NO14~15, NO17, NO.27~30 will be loaded.**

**NETWORK: NO.27~30 will be loaded.**

### 3.4.3 Test

The following detailed settings of the printer are **Print Self Test**, **Media Calibration**, and **Cut Action**.

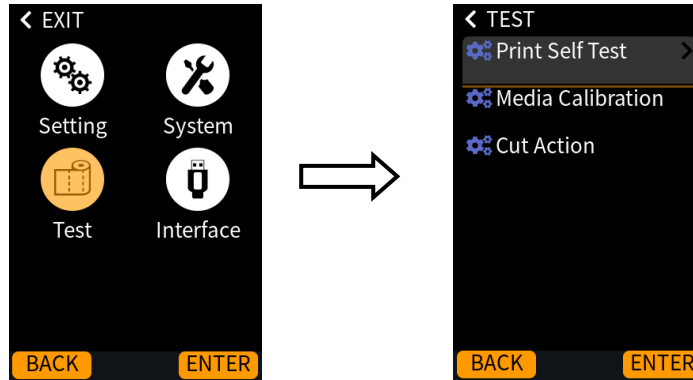

Item	No.	Sub Item	Value	Enter key	Select Key	Back Key
Test				Enter/Right	Up/Down	Back/Left
	25	Print Self Test		Enter		Back
	26	Media Calibration		Enter/Right	Up/Down	Back/Left
			Current Sensor			
			Reflective Sensor	Enter/Right	Left/Right	Back
			Transmissive Sensor			
	27	Cut Action		Enter/Right	Up/Down	Back/Left
			Cut Immediately			
			Cut With Backfeed	Enter/Right	Left/Right	Back
			Reverse Normal			
			Reverse Forcing			

### 3.4.4 Interface

The following detailed settings of the printer are **COM RS-232** and **LAN**.

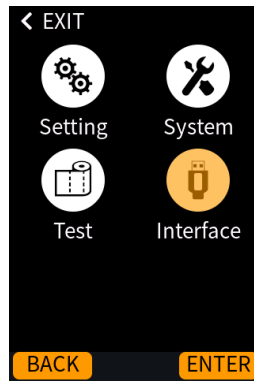

Item	No. Sub Item	Value	Enter key	Select Key	Back Key
Interface			Enter/Right	Up/Down	Back/Left
COM RS-232			Enter/Right	Up/Down	Back/Left
	<b>28</b>	<b>BAUD RATE</b>	Enter/Right	Up/Down	Back/Left
		2400			
		4800			
		9600			
		19200	Enter/Right	Left/Right	Back
		38400			
		57600			
		115200			

**Factory Default: 9600**

**Remark: It should be set to the same value as the host. Restart printer after changing the setting.**

	<b>29</b>	<b>PARITY(RS232)</b>	Enter/Right	Up/Down	Back/Left
		NONE			
		ODD	Enter/Right	Left/Right	Back
		EVEN			

**Factory Default: NONE**

**Remark: It should be set to the same value as the host. Restart printer after changing the setting.**

	<b>30</b>	<b>LENGTH(RS232)</b>	Enter/Right	Up/Down	Back/Left
		8 DATA BITS	Enter/Right	Left/Right	Back
		7 DATA BITS			

**Factory Default: 8 DATA BITS**

**Remark: It should be set to the same value as the host. Restart printer after changing the setting.**

**Remarks:**

➤ **DHCP**

**Range: Disable / Enable**

If printer has been connected to a router, IP address will be assigned automatically by DHCP server after power on. If printer is not connected to a router, with DHCP disabled, settings of IP ADDRESS, SUBNET MASK, and DEFAULT GATEWAY settings will be available on LCD. Every time when DISABLE is changed to be ENABLE, LCD will prompt "ETHERNET CARD UPDATE FINISH...". Then please reboot the printer.

➤ **IP ADDRESS / SUBNET MASK / DEFAULT GATEWAY**

**Range: xxx.xxx.xxx.xxx (0~255)**

**(MAC ADDRESS RANGE: Read only)**

When DHCP is disabled, default IP address is 192.168.1.100. If "\_" sign appears, it means that the DHCP setting is disabled. On the contrary, the DHCP setting is enabled.

1. **FEED/CONFIG.:**

Change contents. (ex. from 000.000.000.000 to 255.255.255.255)

2. **PAUSE/CALIBR.:**

Shift the position of the "\_" character. (ex. from 255.255.255.255 to 255.255.255.255)

3. **CANCEL/RESET:**

Select next function setting. ("\_" sign must at the third digit of each parameter, for example, xxx).

4. **To** change IP ADDRESS or SUBNET MASK, enter DEFAULT GATEWAY setting, press CANCEL button once; LCD will prompt "ETHERNET CARD UPDATE FINISH...".

Then reboot the printer.

## 3.4 Printing Media Calibration & Configuration

Before calibration, be sure media and ribbon (for thermal transfer printing) have been loaded correctly. The label sensor needs to locate properly to index labels' gaps/ notches/ holes. After the media is loaded, please perform media calibration to calibrate the label sensor in advance.

1. Turn off the printer
2. Press and hold the **PAUSE** button and turn on the power.

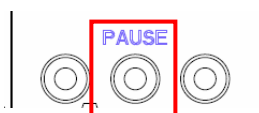

3. When "CALIBRATION ..." is displayed on the LCD, and both READY and MEDIA indicators blink, release the **PAUSE** button.
4. The printer feeds 1 or 2 blank labels.
5. When "READY" is displayed, the READY and MEDIA indicators stop blinking but remain illuminated.

## 3.5 Printing a Configuration Report

Perform a self-test and print a configuration report to check the printer's print quality and internal settings. Follow the steps below:

1. Turn off the printer.
2. Load media and ribbon.
3. Press and hold the **FEED** button while turning on the power.

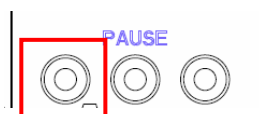

4. When "SELF-TEST ..." is displayed on the LCD, release the **FEED** button.
5. The printer will now print a configuration report, as shown in the example on the next page. All characters will be printed in 2 columns: the right shows characters received from your system, and the left are the corresponding hexadecimal values of the characters. It allows users or engineers to verify and debug the program.



After printing the self-test page, you can view the printer's configuration settings. The self-test page provides valuable information about the printer's current setup, allowing you to verify and ensure that the printer is functioning correctly and set up to meet your specific needs. The printed settings typically include details as follows:

**1. XM4-200-VXX.XX    XXXXXXXX    PPLX**

The firmware version and its build date.

**2. Standard RAM**

Total SDRAM size.

**3. Available RAM**

RAM is able to be used.

**4. Flash Type**

The flash memory type and size.

**5. Available Flash**

Flash is able to be used.

**6. No of DL soft fonts (FLASH)**

The number of fonts is downloaded in Flash.

**7. No of DL soft fonts (RAM)**

The number of fonts is downloaded in RAM.

**8. No of DL soft fonts (HOST)**

The number of fonts is downloaded in USB HOST.

**9. H. Position Adjust**

Move the print position horizontally.

**10. Sensor Type**

The media sensor type such as reflective sensor.

**11. RTC Time**

The date and time of the real-time clock (RTC). The default format is month/day/year (hour:minute:second). If your printer has a built-in RTC, the RTC time shows here.

**12. Max Label Height**

The max label length you can print at a time. For 200 dpi models, it is 100 inches; for 300 dpi models, it is 50 inches.

**13. Print Width**

The print width in dots.

#### **14. Lab Len (Top to Top)**

For non-continuous media, it is the length between the tops of two labels.

#### **15. Speed**

The speed of printing. The unit is inch per second (ips).

#### **16. Darkness**

The current darkness.

#### **17. Print Method**

It is either thermal transfer (TT) or direct thermal (DT) printing. TT requires ribbons and DT doesn't.

#### **18. Print Length**

The total print length.

#### **19. Cut Count**

It counts the times the cutter cuts.

#### **20. RS232 Protocol**

It lists RS-232C settings in the following order: baud rate, data length, parity check, stop bit and flow control.

#### **21. Code page**

The character set table.

#### **22. Media**

The media type in use.

#### **23. Calibration mode**

There are intelli mode or smart mode.

Intelli mode: Just install labels, latch print module, press FEED button once, and then the printer will feed 1-2 labels to detect next gap / black mark before printing. The printer will feed 1-2 labels automatically before printing, if FEED button is not pressed.

Smart mode: Print from the first label immediately according to label length setting. Make sure to carefully align label bottom edge at the tear-off position before printing.

#### **24. Backfeed Enabled/Disabled**

Enable or disable backfeed during the printing process. When it is enabled, the printer moves the paper forward in a predefined length 1 second after printing, and pulls the paper back in a predefined length once the printing begins again. When it is disabled, the printer won't move the paper at all.

#### **25. Cutter Enabled/Disabled**

Enable or disable the cutter during the printing process.

#### **26. Peeler Enabled/Disabled**

Enable or disable the dispenser (peeler) during the printing process.

#### **27. Cutter/Peeler Offset**

Move the cutting line or the peeling position forward or backward. The value in the angle brackets is the offset unit.

#### **28. IP Address**

The static IP address of the printer. The default value is "192.168.1.1".

#### **29. Subnet Mask**

The manually specified subnet mask of the printer. The default value is "255.255.255.0."

#### **30. Gateway**

The manually specified gateway of the printer. The default value is "0.0.0.0."

#### **31. MAC Address**

The unique address assigned to the printer that connects to the internet.

#### **32. DHCP**

When DHCP is enabled, it assigns an IP address to the printer automatically.

#### **33. DHCP Client ID**

It is an arbitrary value sent to the DHCP server to reserve an IP address for the printer.

#### **34. DHCP Host Name**

The name of a DHCP client.

#### **35. SNMP**

When it is enabled, the host gets or sets parameters registered as SNMP entities.

#### **36. Socket Communication**

When it is enabled, the host communicates with the printer via the socket.

### **37. Socket Port**

The socket number of the printer.

### **38. IPv6 Mode**

It determines how you get the IPv6 address of your printer. There are three modes: MANUAL, DHCPv6 or AUTO.

### **39. IPv6 Type**

It is the IPv6 address type of your printer. There are four types: NONE, NORMAL, EUI and ANY.

### **40. IPv6 Address**

The static IPv6 address of your printer.

### **41. Link Local**

The IPv6 address that used in a network segment. It is allocated automatically.

### **42. Product SN**

The serial number of product.

### **43. USB SN**

The Serial number of USB host.

### **44. CG Enable**

Printer is able to use True Type font.

### **45. TPH and Cutter Offset**

For developers to debug.

### **46. Reflective Sensor Gap Calibration**

For developers to debug.

### **47. See-Through Sensor Gap Calibration**

For developers to debug.

### **48. Reflective Sensor Profile**

For developers to debug.

### **49. See-Through Sensor Profile**

For developers to debug.

### **50. Ribbon Sensor Profile**

For developers to debug.

### **51. Reflective Sensor Offset**

For developers to debug.

## 52. See-Through Sensor Offset

For developers to debug.

Note:

The patterns displayed in items 45 to 52 are as shown in the schematic below:

```
ot(0,0)<0.1dot,0.01mm>  
rm(0,0)<1+ 0-,0.01mm>  
sm(0,0)<1+ 0-,0.01mm>  
rv(241,136,104)<0.01v><P>  
sv(265,158,106)<0.01v><P>  
bv(329,6,322)<0.01v><P>  
rso(0)<0.01mm>  
sso(0)<0.01mm>  
ragc(202)<0.01v><P> 1v(3)  
sagc(156)<0.01v><P> 1v(4)  
TPL: 0
```

## 53. Font Image

You can use them as the reference to check your label font.

Note:

The patterns displayed in items 45 to 52 are as shown in the schematic below:

```
This is internal font 1. 0123456789 ABCabcXyz  
This is internal font 2. 0123456789 ABCabcXyz  
This is internal font 3. 0123456789 ABCabcXyz  
This is internal font 4. 0123456789 ABCXYZ  
THIS IS INTERNAL FONT
```

## 54. TPH Test Pattern

You can use them to check broken pins on the printhead.

Note:

The patterns displayed in items 45 to 52 are as shown in the schematic below:

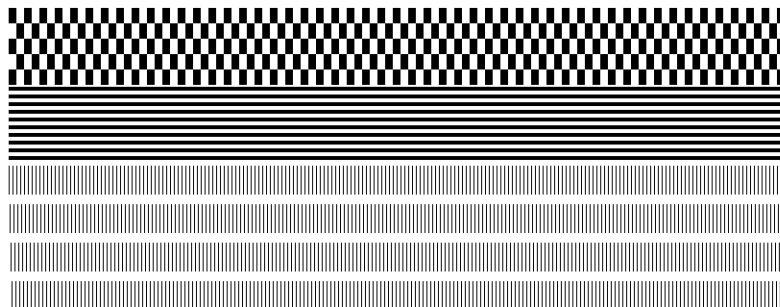

If your printer has a Wi-Fi module, your PPLB configuration label will contain the following entries:

```
WLAN FW VERSION: 1.00 _____ 1
                   DATE: 2015.05.26 _____ 2
WLAN IP ADDRESS: 0.0.0.0 _____ 3
WLAN SUBNET MASK: 0.0.0.0 _____ 4
WLAN GATEWAY: 0.0.0.0 _____ 5
WLAN MAC ADDRESS: 00-80-92-4F-77-35 _____ 6
WLAN DHCP: AUTO _____ 7
WLAN DHCP HOSTNAME: 00-80-92-4F-77-3 _____ 8
                   : 5
WLAN SOCKET PORT: 9100 _____ 9
WLAN SSID: WIRELESS PRINTER _____ 10
WLAN MODE: Infrastructure _____ 11
WLAN COUNTRY CODE: USA _____ 12
WLAN CHANNEL: AUTO _____ 13
WLAN NETWORK AUTHENTICATION: Open _____ 14
WLAN WEP: OFF _____ 15
```

### 1. FW Version

WLAN board firmware version.

### 2. Date

WLAN board firmware version date.

### 3. IP Address

The IP address of your printer. When DHCP is enabled, it shows the automatically assigned IP address; when DHCP is disabled, it shows the manually specified IP address.

### 4. Subnet mask

The netmask of your printer. When DHCP is enabled, it shows the automatically assigned netmask; when DHCP is disabled, it shows the manually specified netmask.

### 5. Gateway

The gateway of your printer. When DHCP is enabled, it shows the automatically assigned gateway; when DHCP is disabled, it shows the manually specified gateway.

### 6. Mac address

The unique address assigned to your printer that connects to the internet.

### 7. DHCP

When DHCP is enabled, it assigns an IP address to your printer automatically.

### 8. DHCP Hostname

The name of a DHCP client.

### 9. Socket Port

The socket number of the printer.

**10. SSID**

Short for service set identifier. It is the name of a wireless local area network.

**11. Mode**

There are ad-hoc and infrastructure mode. Refer to Print Tool Network type description from Technical manual.

**12. Country Code**

The country or region.

**13. Channel**

The Wi-Fi channel.

**14. Network Authentication**

There are six mode. Refer to Printer Tool Network authentication description from Technical manual.

**15. WEP**

Refer to Printer Tool Wep description from Technical manual.

## 3.6 Resetting to Factory Defaults

Be cautioned that this will reset all printer settings back to defaults; if possible, print the configuration label in advance before reset. All settings stored in FLASH memory are retained even after turning off the printer.

To reset the printer to factory default settings:

1. Turn off the printer.
2. Press and hold the **CANCEL** button and turn on the printer.

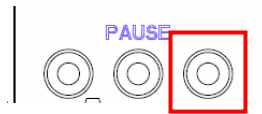

3. When “RESET ...” is displayed on the LCD and the READY indicator blinks, release the **CANCEL** button.
4. When “READY” is displayed on the LCD, the READY indicator stops blinking but remains illuminated.
5. The following information is now back to defaults:
  - Label parameters
  - Heat (Darkness)
  - Speed
  - Others for specific emulation



**Note:**

Print length meter which indicates label length already printed cannot be reset.



## 3.7 Media sensing

The printer offers two types of media sensors: transmissive sensor and reflective one. They are used for detecting specific media types. Both sensor types are installed together as a movable module.

### 3.7.1 Transmissive sensor

The transmissive sensor is used for detecting gaps across the entire width of the label.

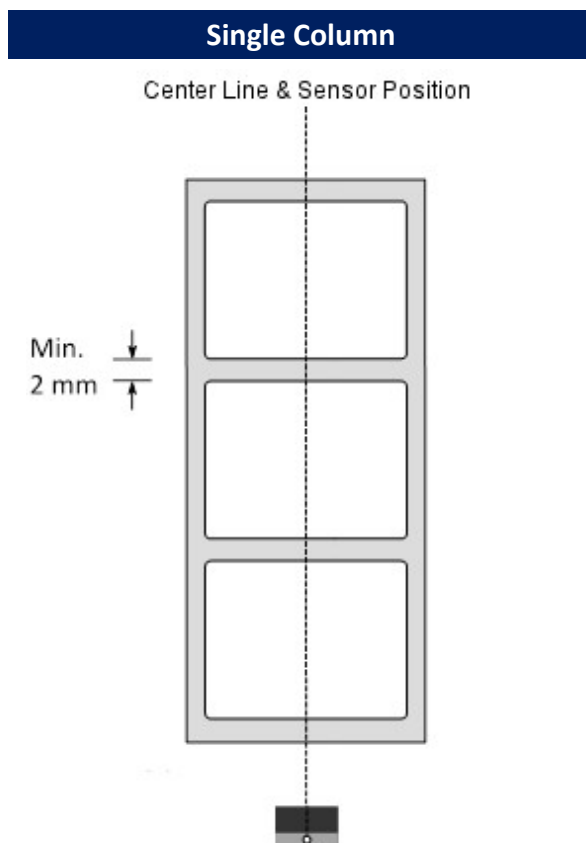

### 3.7.2 Reflective sensor

The reflective sensor detects gaps, notches and black marks.

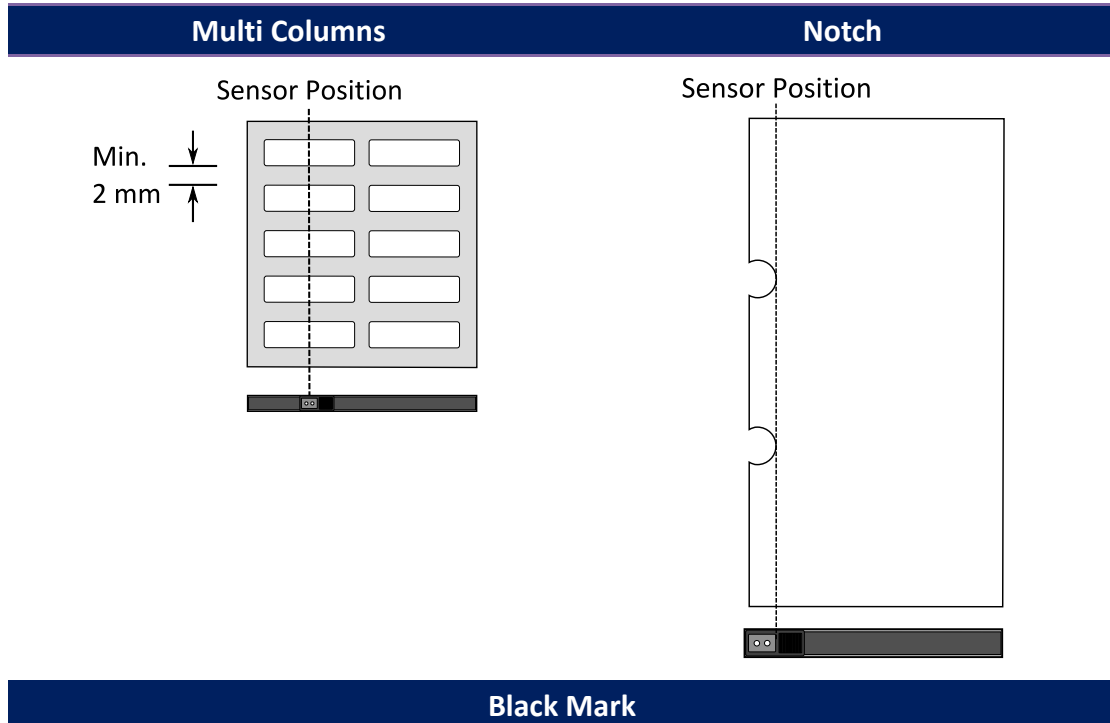

Flip the media so the black-mark side is facing down to align with the sensor.

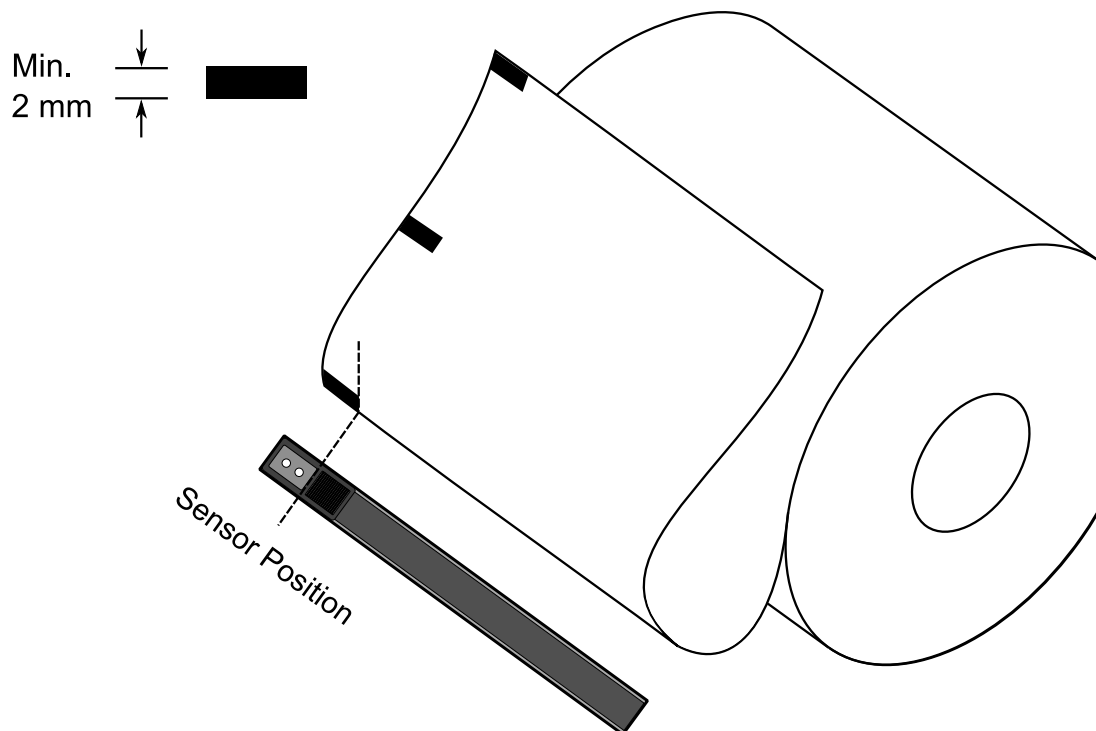

### 3.7.3 Adjust Position of Label Sensor

Function of the label sensor is to detect the gap, notch, or holes of labels, to help the printer for accurate print positions and label length. For labels with gaps, label sensor can be positioned wherever media locates. If labels with notches or holes are in use, pull in or out Paper Sensor Position Lever, to horizontally adjust position of label sensor.

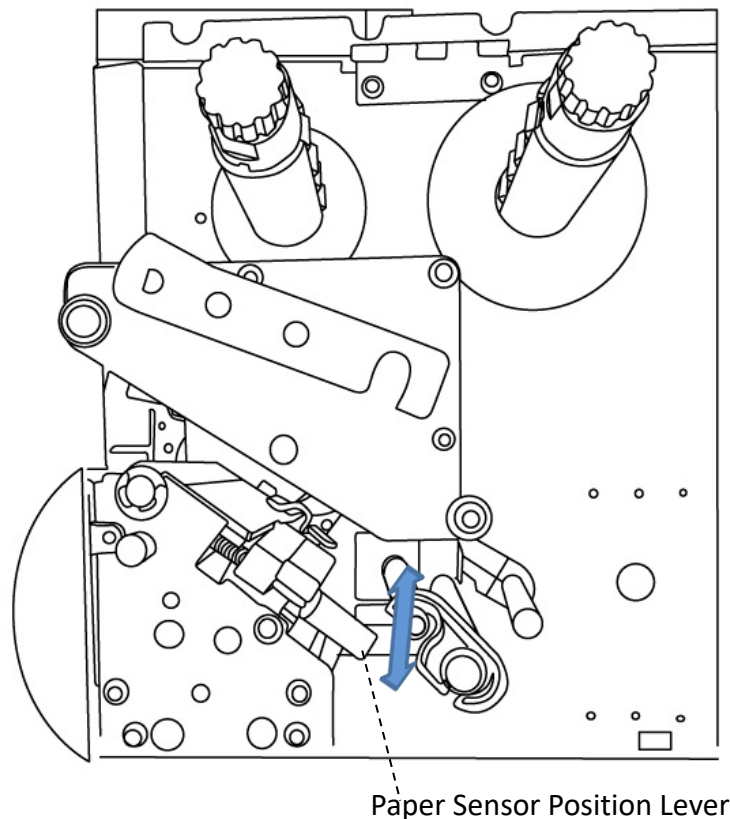

- Make sure the Media sensor position mark locates right on notch or hole of labels. Check below.

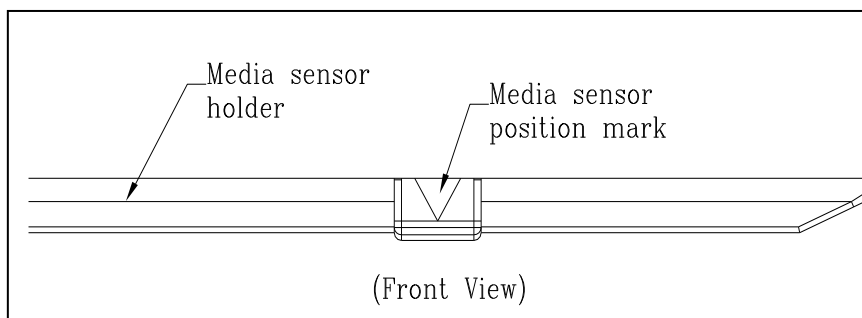

## 3.8 Communications

### 3.8.1 Interfaces and Requirements

This printer comes with USB type A and type B interfaces, a nine-pin Electronics Industries Association (EIA) RS-232 serial data interface, and a GPIO interface(optional).

#### ■ USB Interface Requirements

The Universal Serial Bus (USB) interface is compatible with your existing PC hardware. The USB's "plug and play" design makes installation easy. Multiple printers can share a single USB port/hub. The different usage of type A and B as below.

USB type A	USB flash drive, USB keyboard, or USB scanner
USB type B	To connect the printer to a PC for initial setup and configuration

#### ■ Serial (RS-232) Port

The required cable must have a nine-pin "D" type male connector on one end, which is plugged into serial port located on the back of the printer. The other end of the cable connects to a serial port on the host computer. For technical and pin-out information, please refer to RS-232C in this manual.

#### ■ General-purpose input/output (GPIO)

The pins depend on the application and the signal is user selectable. The function is diversity. For general-purpose I/O, signals programmed as inputs can cause CPU to interrupt. For more information, contact your local dealer.

## ■ Ethernet Module Status Indicators

The indicators with two different colors help users understand the status of Ethernet:

LED Status	Description	
<b>Both Off</b>	No Ethernet link was detected.	
<b>Blinking</b>	The printer waits for the printer to be ready. It will take about a few seconds to be ready.	
<b>Orange (Yellow)</b>	Duplex/COL LED	On: Full duplex Off: Half duplex Blinking: Collision occurs
<b>Green</b>	Link/Activity LED	On: link up Off: link down Blinking: activity

## 3.9 Driver installation

The printer driver is compatible with Windows Vista/7/8/10, Linux, macOS, and Raspberry Pi. You can use it to print to any popular software application, including Argox Bartender UL label editing software or MS Word, etc., on these operating systems.

Drivers can be downloaded from Argox website: <https://www.argo.com/>.

### 3.9.1 Installing a Plug and Play printer driver (for USB only)



**Note:**

We strongly recommend that you use the Seagull Driver Wizard instead of the Microsoft Windows Add Printer Wizard when installing and updating your Drivers by Seagull.

(Even though the "Add Printer Wizard" is from Microsoft, it too easily performs a number of tasks incorrectly when updating existing drivers. It also badly handles the situation where a printer driver is already in use by a Windows application.)

1. Turn off the printer. Plug the power cable into the power socket on the wall, and then connect the other end of the cable to printer's power socket. Connect the USB cable to the USB port on the printer and on the PC.
2. Turn on the printer. If the printer supports Plug-and-Play, and you have successfully connected it using a USB cable, then the Windows Add Hardware Wizard will automatically detect the printer and display a dialog that allows you to install a driver. Click Cancel and do not install the driver using this wizard.

3. Run the driver from Argox website. On the prompt, Windows Printer Driver, select "I accept..." and click "Next".

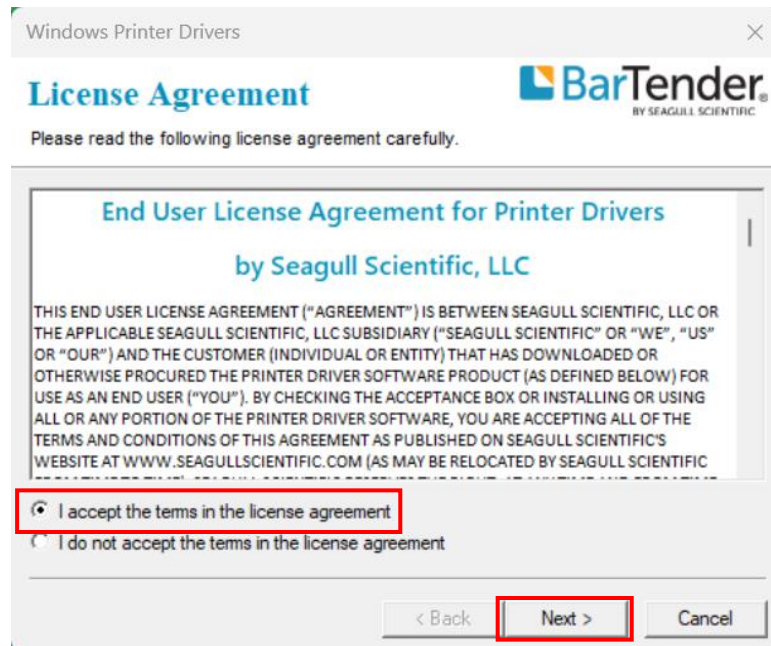

4. Assign the directory to keep Seagull driver and click "Next".

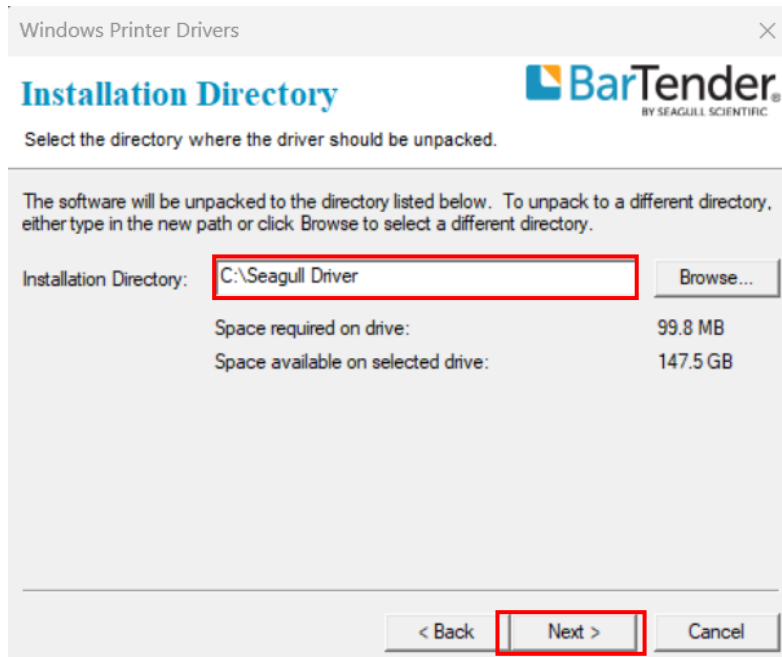

5. Click "Finish".

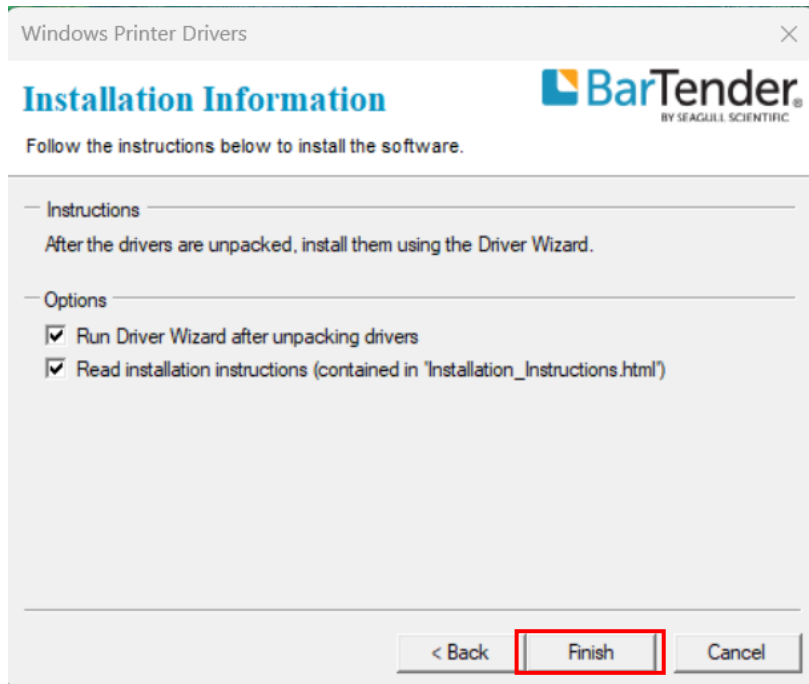

6. Select Install printer drivers and click "Next".

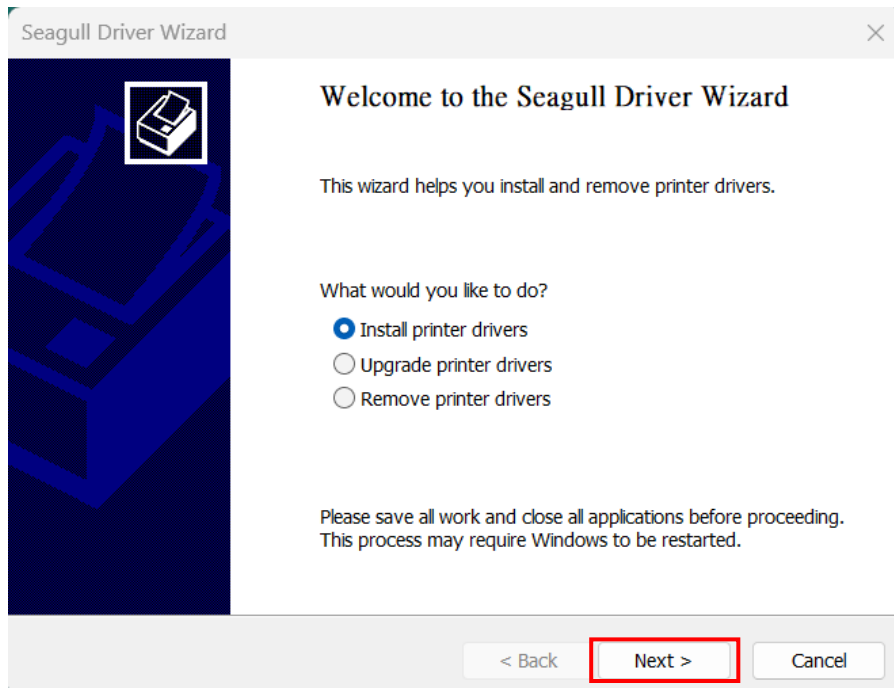



7. On the Seagull Driver Wizard prompt, select the first radio button to “Install a driver for a Plug and Play printer”. Then, click “Next.”

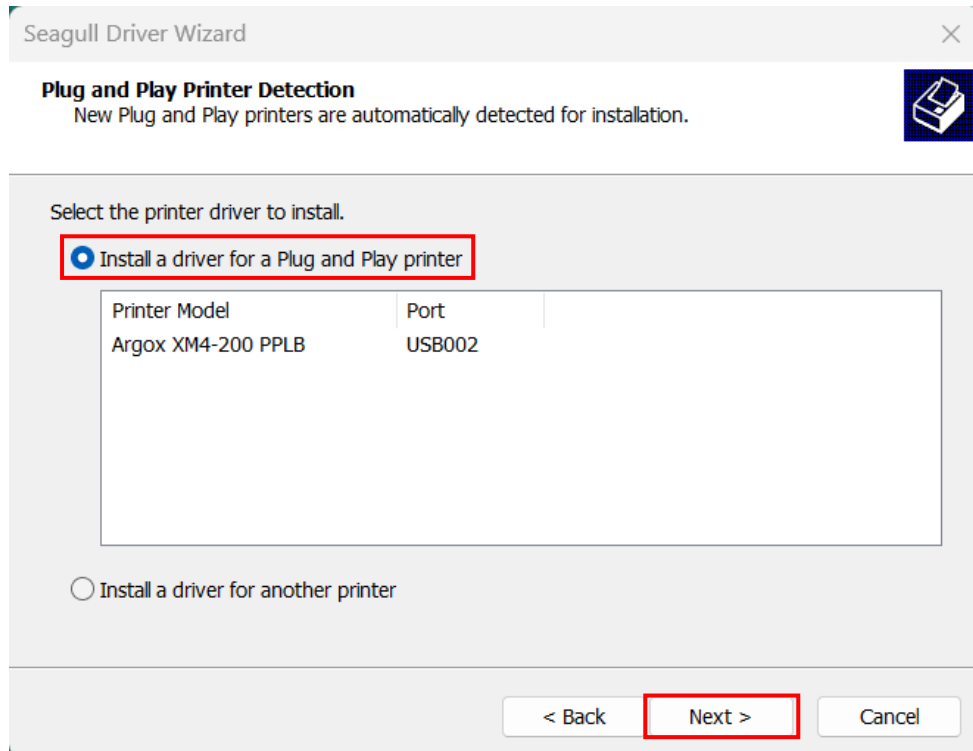

8. Enter the printer’s name (i.e. Argox XM4-200 PPLB) and select "do not share this printer", and click "Next".

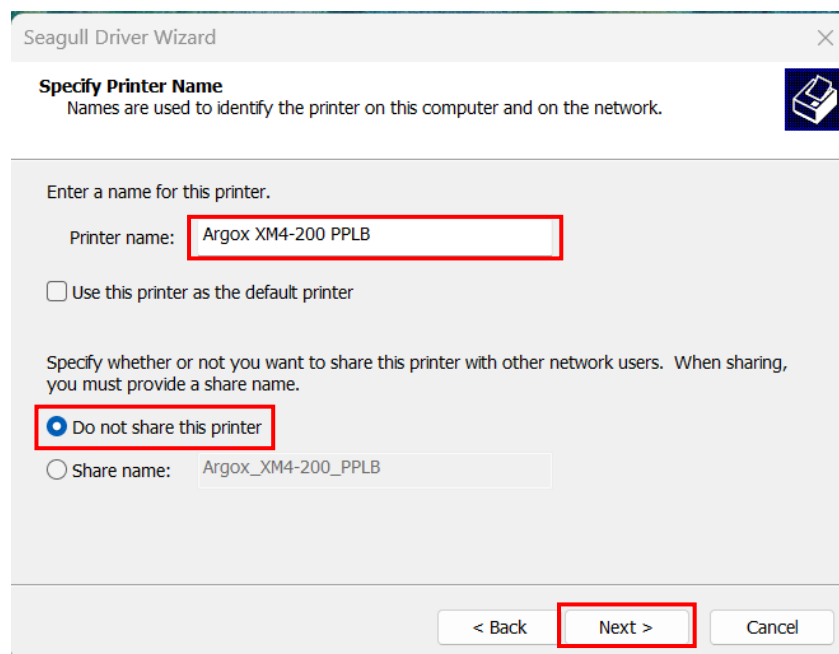

9. Check all the data on the showing screen; if it is correct, click "Finish".

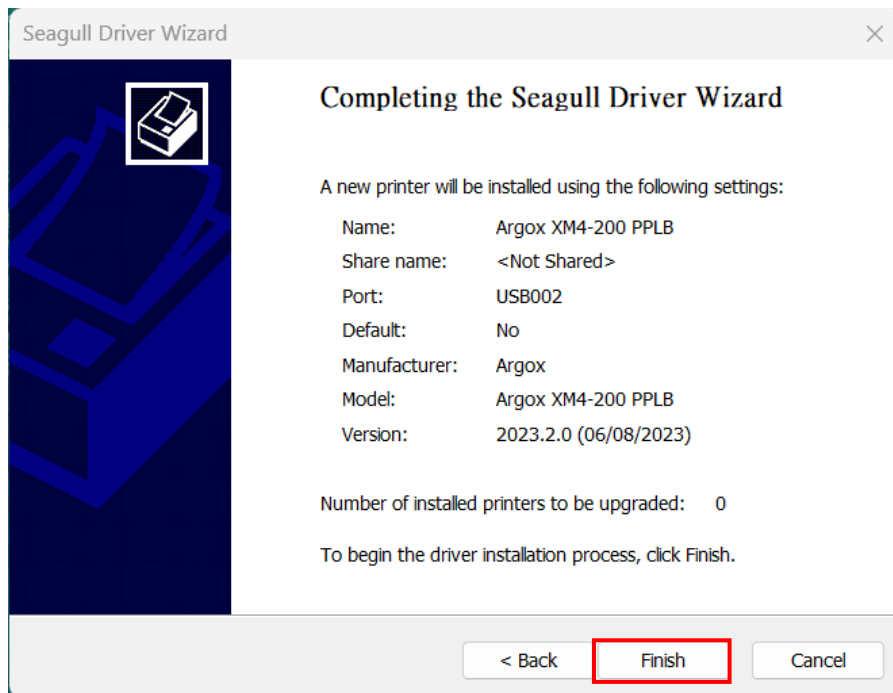

10. Then the related files have been copied to your system, click "Finish".
11. After driver installation is complete, click "Close". The driver should now be installed.

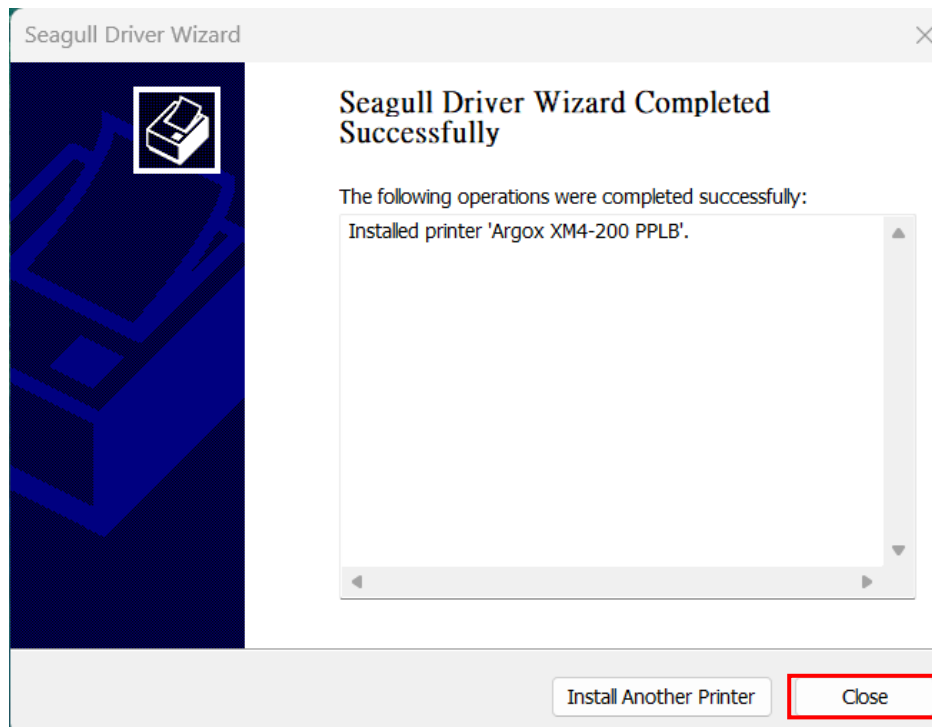

## 3.9.2 Installing a Printer Driver (for other interfaces except USB)

1. Turn off the printer. Plug the power cable into the power socket on the wall, and then connect the other end of the cable to the printer's power socket. Connect the serial cable, or Ethernet cable to the proper port on the printer and your computer.
2. Run the driver from the Argox website. On the prompt, Windows Printer Driver, select "I accept..." and click "Next."

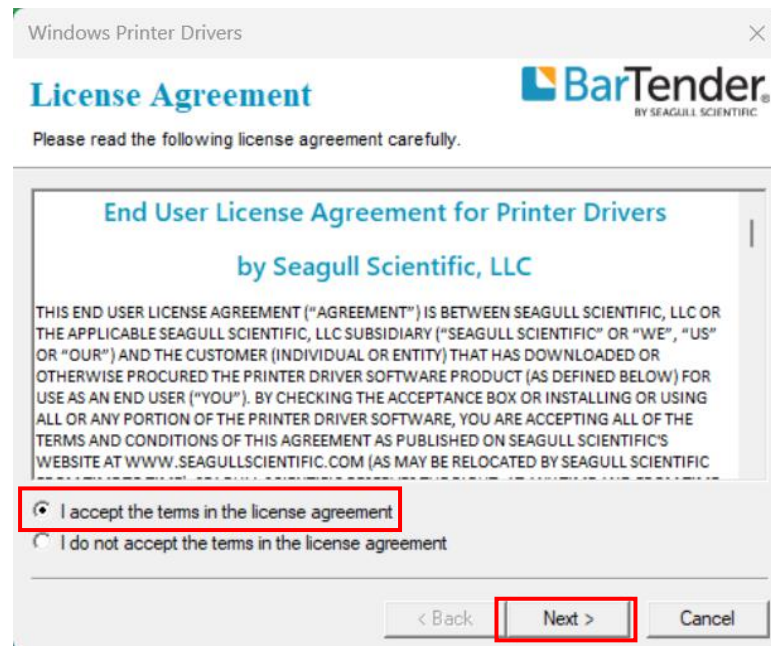

3. Assign the directory to keep Seagull driver and click "Next".

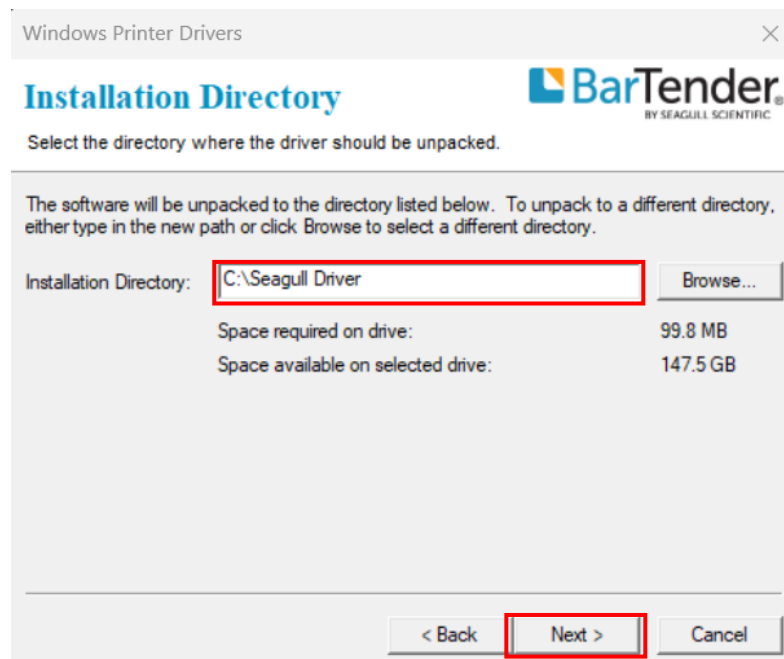

4. Click "Finish".

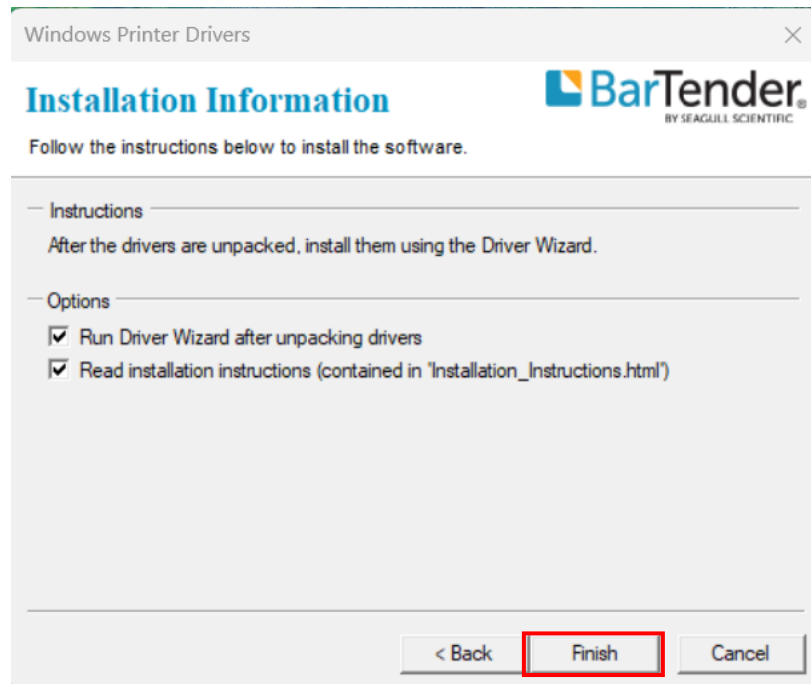

5. Select Install printer drivers and click "Next".

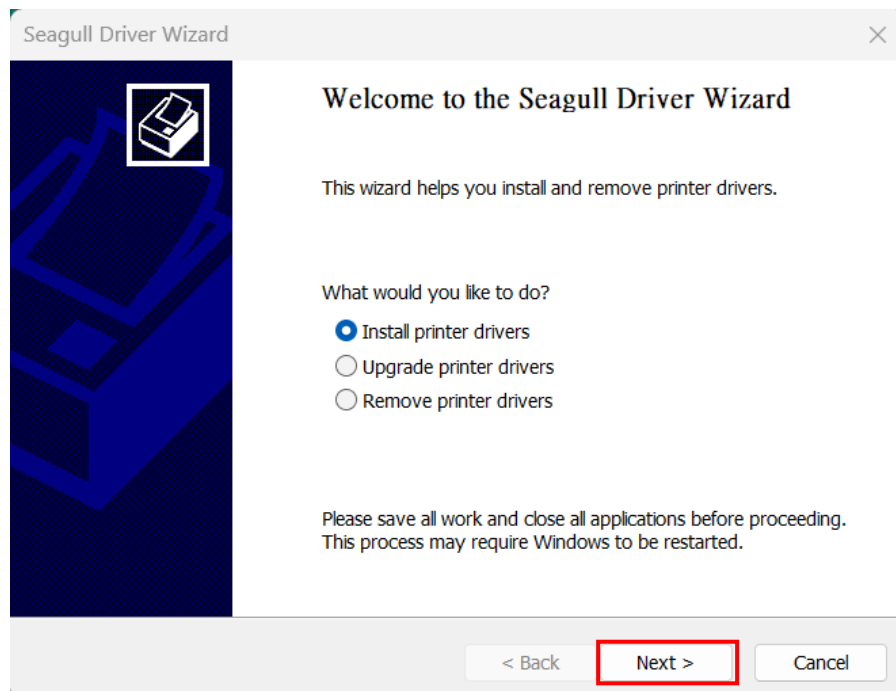

6. Make sure the printer is connected to a PC, select “Other”, and click “Next”.

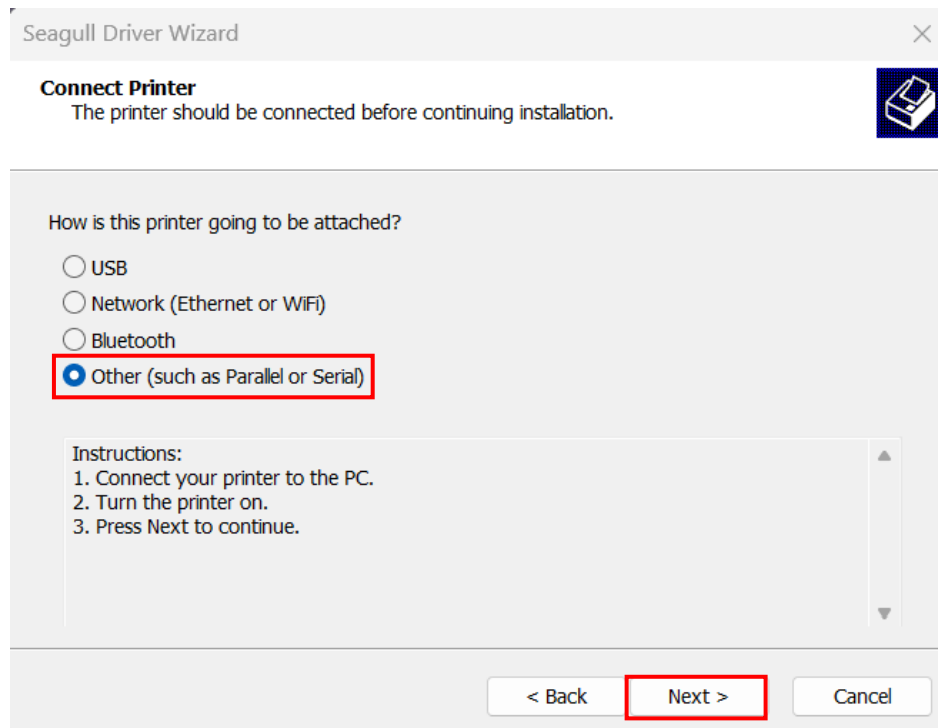

7. Select a model and emulation - the following examples are based on the model: XM4-200 PPLB.

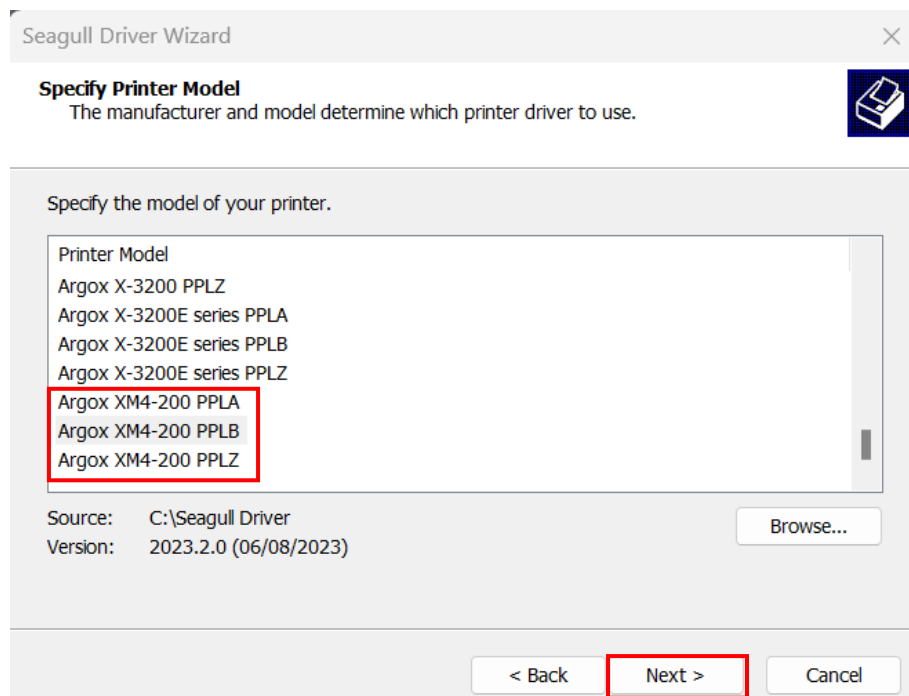

8. Select the port of the printer and click "Next".

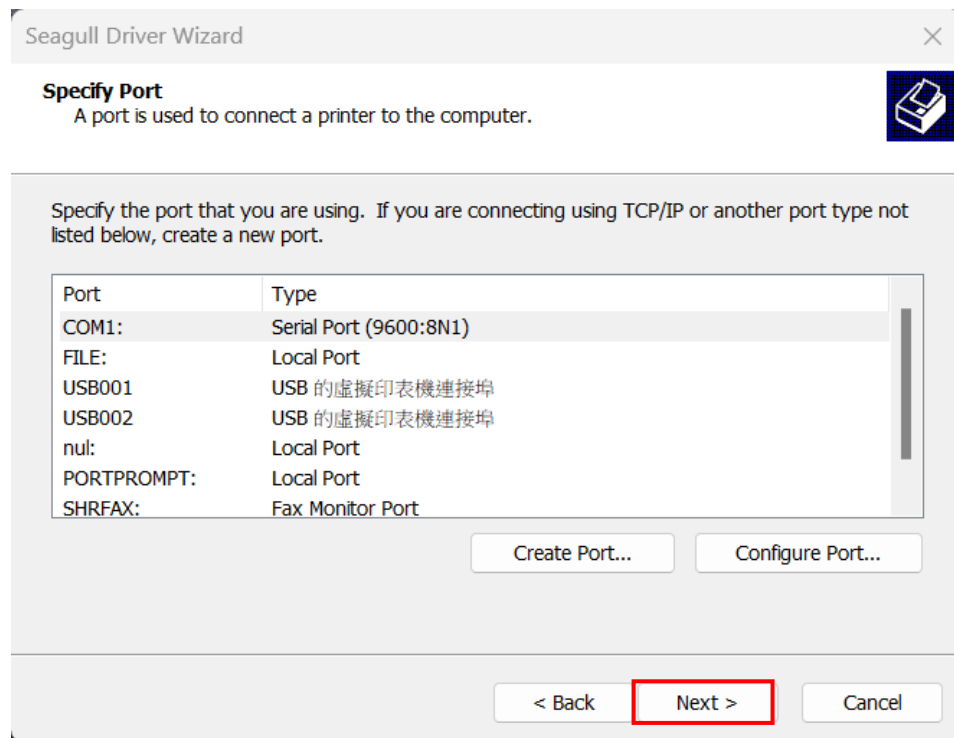

9. Enter the printer's name (i.e. Argox XM4-200 PPLB) and select "do not share this printer", and click "Next".

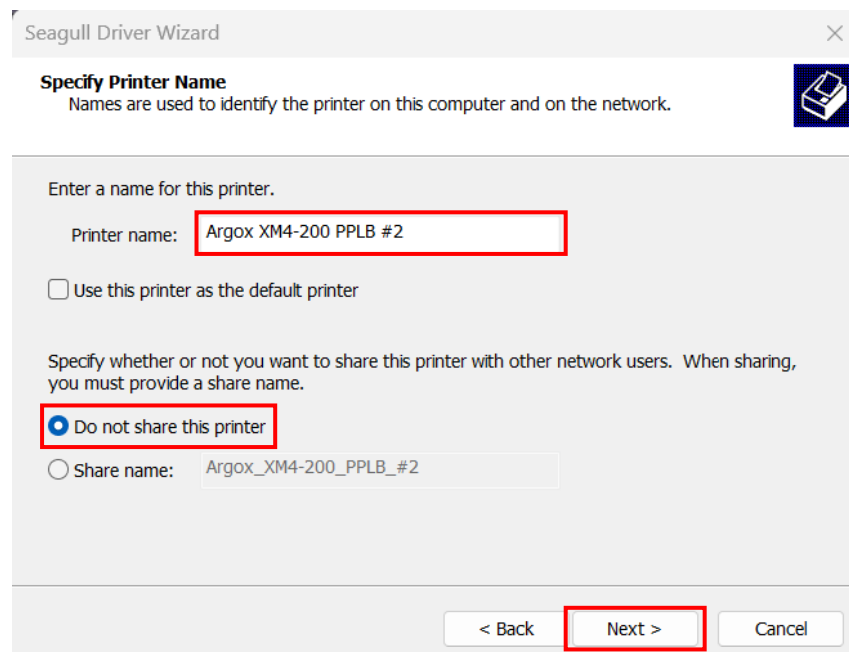

10. Check all the data on the showing screen, if it is correct, click "Finish".

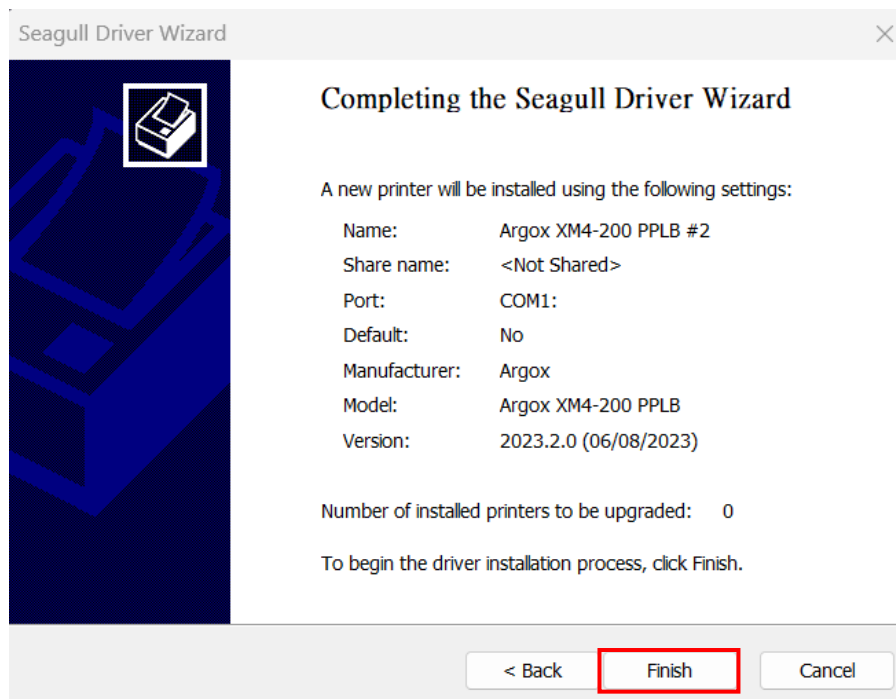

11. After the related files have been copied to your system, click "Finish".

12. After driver installation is complete, click "Close". The driver should now be installed.

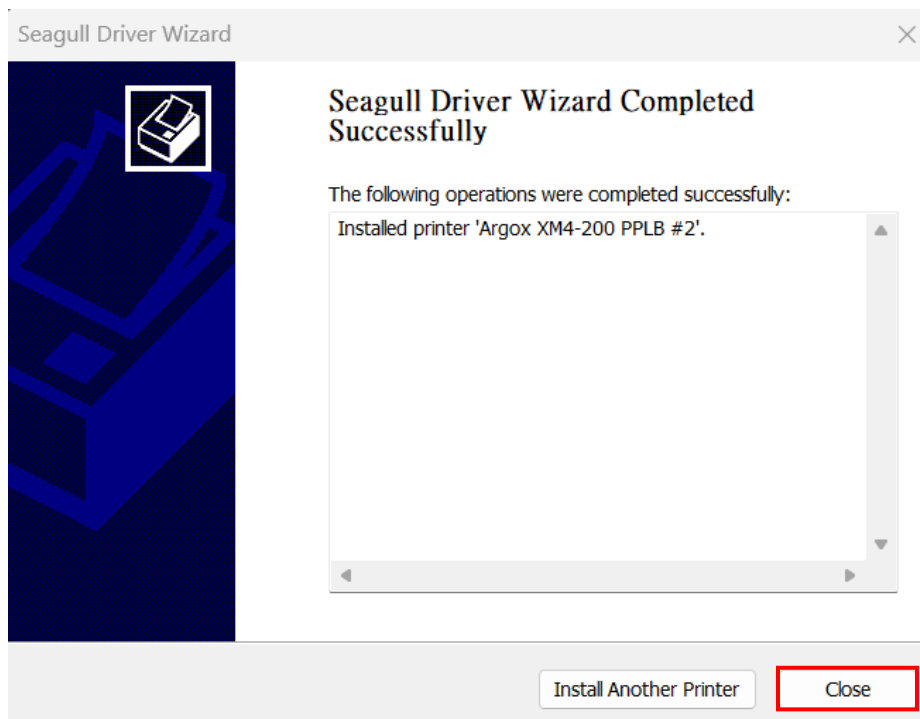

## 4 Configuration on Web Setting Tool

Before doing settings for your printer, be sure that you have a LAN cable. The cable is connected to the LAN connector of your printer. The LAN connector is an 8-PIN RJ45 type modular connector. Please use the LAN cable of CAT 5 of a proper length to connect the LAN connector on the printer to a LAN hub as appropriate.

The default static IP address of the printer is 0.0.0.0 and the default listen port is 9100. For the first time, to configure your printer through the web setting tool, you must still follow the step-by-step instructions below.

### 4.1 Attaching the power cord

1. Make sure the printer power switch is set to the **OFF** position.
2. Insert the power supply's connector into the printer power jack.
3. Insert the AC power cord into the power supply.

**Important: Use only the power supply listed in the user instructions.**

4. Plug the other end of the AC power cord into the wall socket.



**Do not plug the AC power cord with wet hands or operate the printer and the power supply in an area where they may get wet.**  
**Serious injury may result from these actions!**

### 4.2 Connecting the printer to a LAN hub

Use a LAN cable of CAT 5 of a proper length to connect the LAN connector on the printer to a LAN hub to which your desktop or laptop PC as a host terminal is also connected.



## 4.3 Getting the IP address of the printer

You can have the printer run a self test to print a configuration label, which helps you get the IP address of your printer connected to the LAN hub.

1. Turn off the printer.
2. Press and hold the **FEED** button, and turn on the printer.
3. Both status lights glow solid amber for a few seconds. Next, they turn to green shortly, and then turn to other colors. When LED 2 turns to green and LED 1 turns to amber, release the **FEED** button.
4. Press the **FEED** button to print a configuration label.
5. Get the IP address of the printer from the printed configuration label.

## 4.4 Logging in to the web setting tool

The Web Setting Tool is a build-in setting tool in firmware for ARGOX serial printers. User can connect to the supported ARGOX serial printers with browsers to get or set the printer settings, update firmware, download font, etc.

After obtaining the IP address of the LAN printer from the printed configuration label, you can connect to the printer with the supported browsers by input the IP address of the printer, *for example, 192.168.6.185*, in the URL field and connect to it.

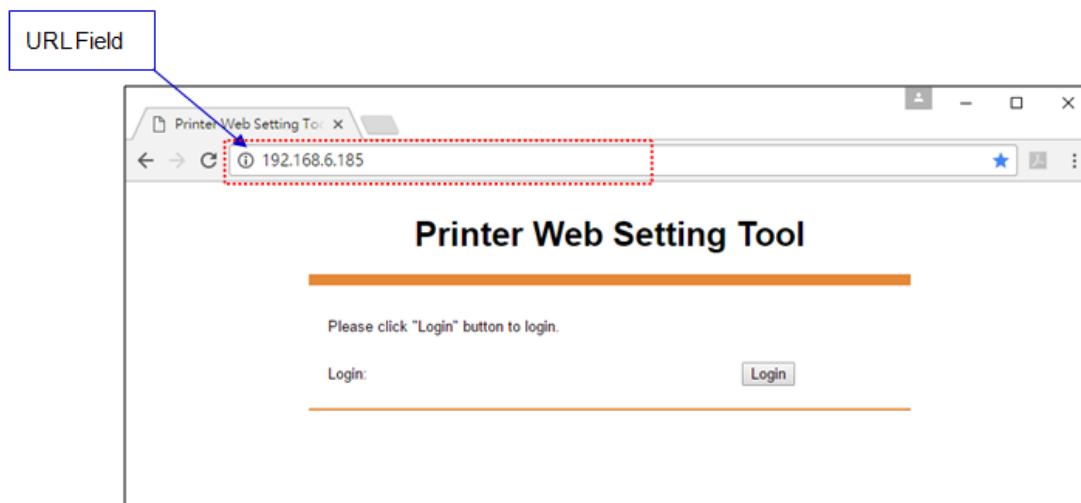

When the connection is successful, the Login page will be displayed. Input the user name and password to log in to the web setting tool. The default user name and the default password are given below:

Default user name: admin

Default password: admin

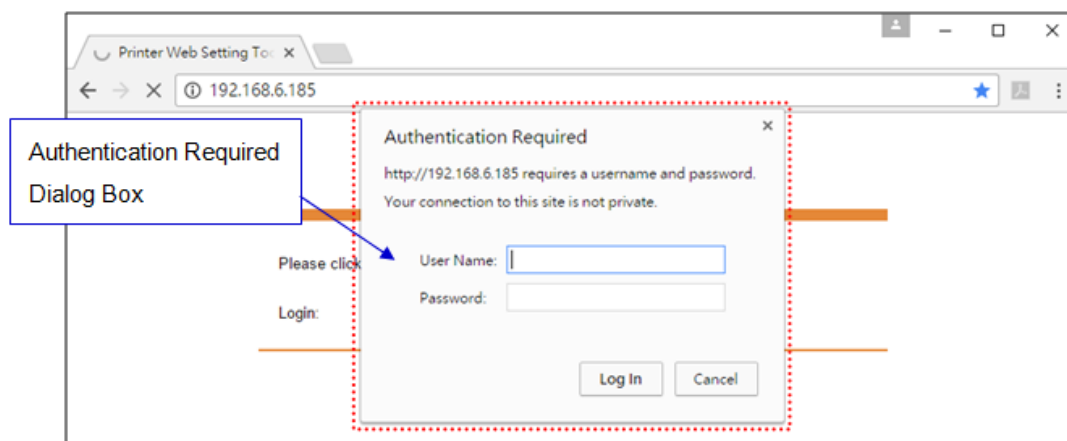

The default password can be changed in the "Device Setting \ Change Login Password" webpage.

This web setting tool can be used to manage multiple label printers in the same local area network segment under the Windows operating system as long as there is no conflicting IP address in the network. You can also check each of the MAC addresses listed in this tool against the MAC address label you can find on each of the printers.

The label printer that is connected through TCP/IP in the way like a directly connected local printer can be used with a random PC connected in the same local area network segment. So, through the tool, all commands applicable to the LAN mode can work on the printer in the same way, as the printer must be configured upon the TCP/IP communication protocol with the IP address of the printer.

When doing settings through a tablet PC or Smart Phone for the printer working in infra mode, please set the same network segment of the host terminal to that of the printer, for example, 192.168.6.XXX (1~254). The Wi-Fi mode for the printer is infra mode that can be searched by the wireless device manager of the host terminal.

## 5 Maintenance

Vertical streaks in the printout usually indicate a dirty or faulty print head. (Refer to the following examples.) Clean the print head. If the problem persists, replace the print head.

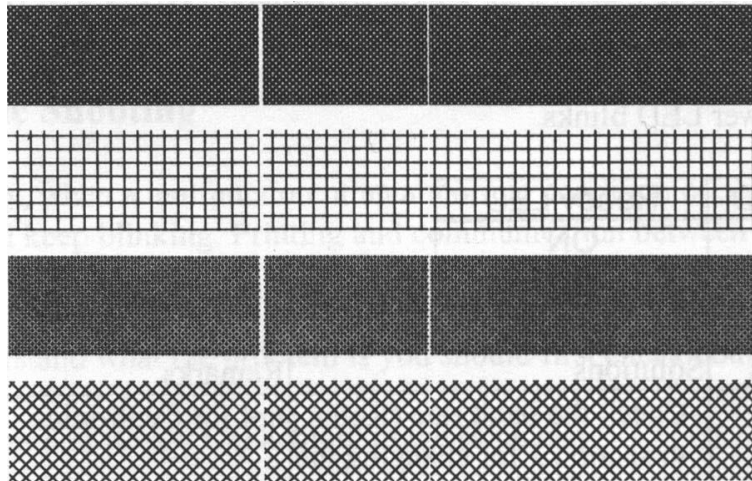

For unstable ribbon roll rotation, check the label path and make sure the head latch is securely closed.

Poor printout quality:

- The ribbon may not match the media in use.
- Adjust the Darkness (heat temperature).
- Slow down the print speed.
- Refer to the following and clean the related spare parts.

## 5.1 Cleaning

To maintain print quality and prolong the printer's life, you need to perform some routine maintenance. Daily maintenance should be done for high volume printing, and weekly for low volume printing.



**Warning** Always turn off the printer before cleaning.

### 5.1.1 Printhead

It is essential to keep printhead clean if you want the best print quality. We strongly recommend that you clean the printhead when you load a new media roll. If the printer is operated in critical environment, or the print quality declines, you need to clean the printhead more frequently.

Keep in mind these things before you clean:

- Keep the water away in case of corrosion on heating elements.
- If you just finish printing, wait until the printhead cools down.
- Do not touch the printhead with bare hands or hard objects.

Cleaning steps:

1. Moisten a soft cloth or a cotton swab with ethyl alcohol.
2. Gently wipe the printhead in one direction. That is, wipe it only from left to right or vice versa. Do not wipe back-and-forth, in case dust or dirt attaches to the printhead again.



**Note** Printhead warranty becomes void if printhead's serial number is removed, altered, defected, or made illegible, under every circumstance.

## 5.1.2 Platen Roller

The platen roller is also important for print quality. Dirty platen roller may damage the printhead. Clean the platen roller right away if the adhesive, dirt or dust accumulates on it.

1. Moisten a soft cloth with absolute ethyl alcohol.
2. Gently wipe the platen roller to remove the dust and adhesive.

## 5.2 Printer Adjustments

### 5.2.1 Printer Head Pressure Adjustment



**Note** The printer head pressure adjustment is available to XM4 series model which is with the serial number of 21C58061 or former. You can also contact your local service center or printer supplier for technical support.

Printing quality can be fine adjusted based on which area on the label the printing quality discrepancy is located. There are two ways to enhancement pressure. Spring pressure pad can be quickly adjusted in three levels can for pressure numerous. A dial is provided to allow the operator to slightly adjust the pressure.

**TPH Pressure Adjustable  
(3 Levels)**

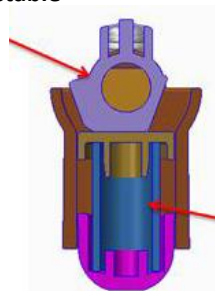

TPH Spring

Spring pressure pad

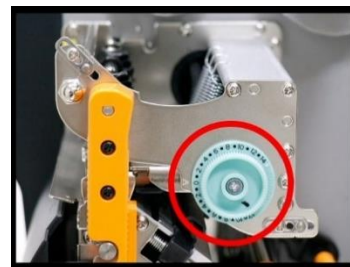

Scale dial

### Adjust Spring pressure pad

**Step.1** Please use either tool to switch the pressure level.

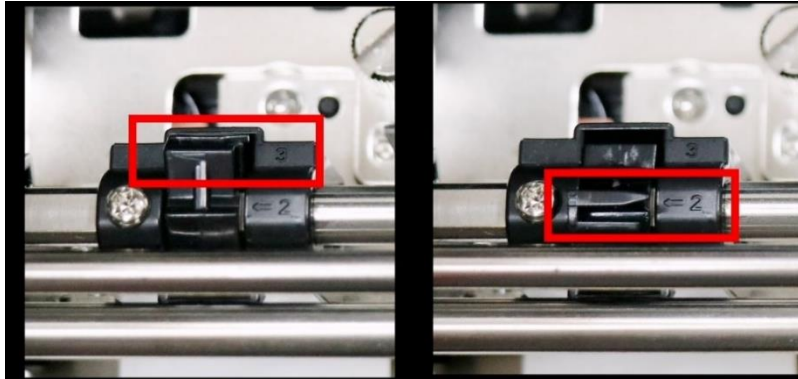

**Step.2** Move the pad in one of the 3 positions. Among Position 1, Position 2 and Position 3, Position 3 is the thickest. If you want more pressure, move pad to position 3.

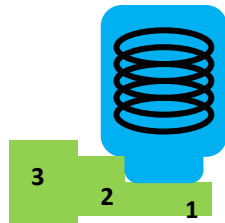

Switch to position 1 (- pressure)

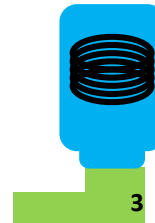

Switch to position 3 (+ pressure)

### Adjust printer head rack

**Step.1** Turn the dial in clockwise or counterclockwise direction.

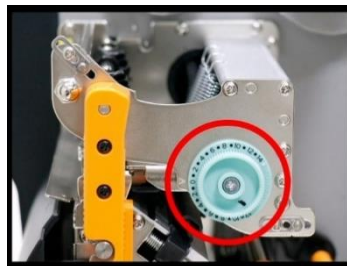

**Step.2** Turn printer head rack clockwise to increase pressure or counterclockwise to decrease pressure.

### Clockwise (+ pressure)

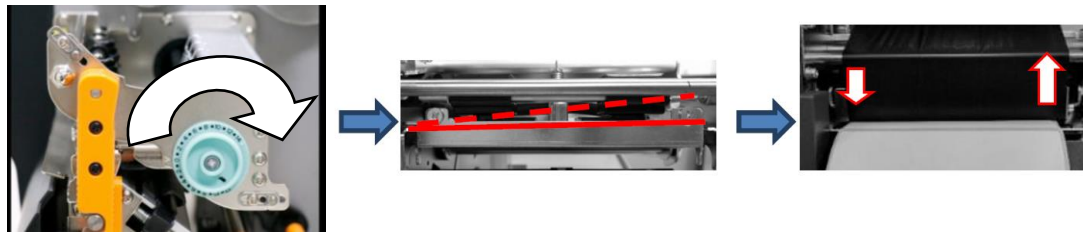

### Counter-clockwise (- pressure)

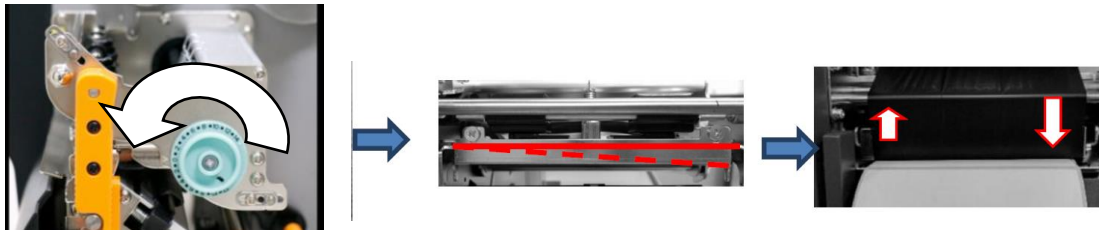

Repeat the same process until the printing quality is well balanced on both ends of the label. Once the desired quality has been reached, please make note on the new setting of **Adjust Spring pressure pad, printer head rack position** and the type number of ribbon used in this printing task for future reference.



**Note** To print small labels, such as 1-2 inch labels, please adjust the pressure range of the print head.

## 5.2.2 Ribbon Tension Adjustment

Both ribbon supply spindle and ribbon pickup spindle are equipped with control knobs to adjust ribbon tension. The control knobs can rotate to both directions.

If the ribbon is wrinkled at ribbon supply, rotate clockwise control knob of ribbon supply, to increase ribbon tension at ribbon supply and further improve ribbon wrinkle.

- Rotate control knob clockwise to increase ribbon tension.

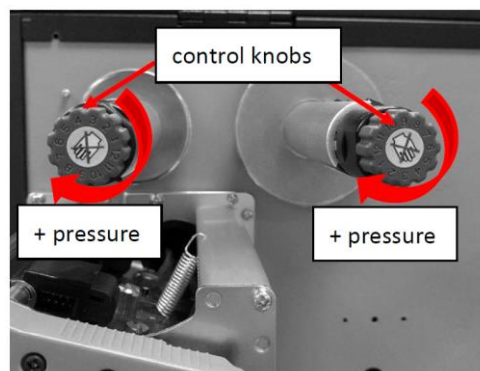

Too much tension at ribbon supply may result in ribbon not moving smoothly. Once it happens, rotate counterclockwise control knob of ribbon supply, to reduce ribbon tension to balance the tension.

- Rotate control knob counterclockwise to reduce ribbon tension.

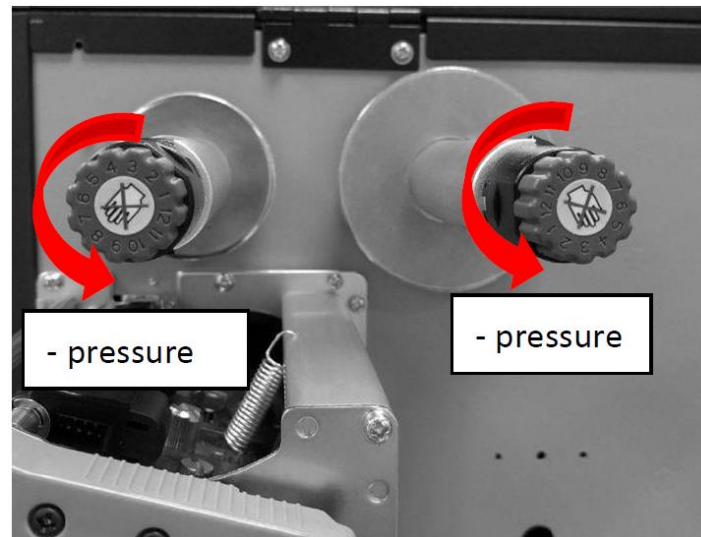

**[Remark]:**

The ribbon shaft has its user-friendly feature to allow users to adjust the tension of ribbon shaft by rotating the knob. User can reset to factory default tension by adjusting the ribbon shaft while the black line was aligned to the marked arrows. The default setting when shipped from Argox factory is shown as Figure 2 – the two arrows are in line with the black line.



---

**Note** If the ribbon is wrinkled at ribbon pickup, rotate counterclockwise control knob of ribbon pickup, to decrease ribbon tension at ribbon pickup and further improve ribbon wrinkle. If the tension is too little at ribbon pickup, ribbon will not move smoothly, and needs control knob to rotate clockwise to increase tension.

---



## 5.2.3 Printing Wrinkle Adjustment

During printing, ribbon may wrinkle and cause abnormal printing quality. The following describes how to solve ribbon wrinkle accordingly.



Once the printouts as above appear, the possible cause may be the unequal positions of Ribbon Bracket, which needs to be adjusted properly to make its heights equally the same at both sides. Steps to adjust are as below:

1. Loosen the screws at both sides and rotate counter-clockwise:

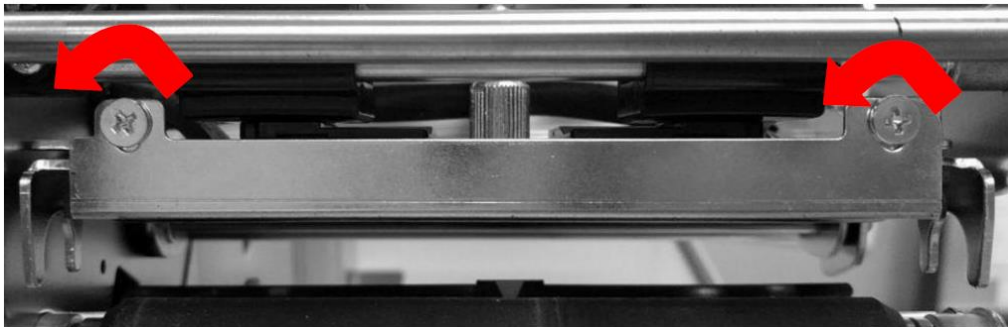

2. Make sure the Ribbon Bracket is at its **lowest** position first; then tighten up the screws by rotating clockwise.

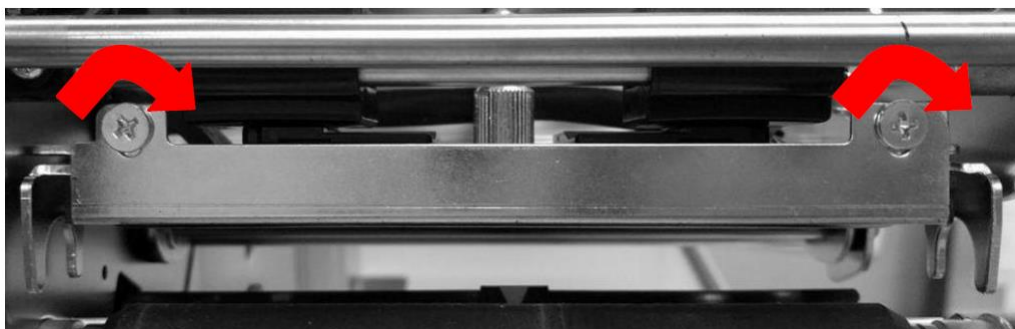

3. Alternatively, please reduce the occurrence of ribbon wrinkles through the ribbon wrinkle adjustment mechanism on both ends.

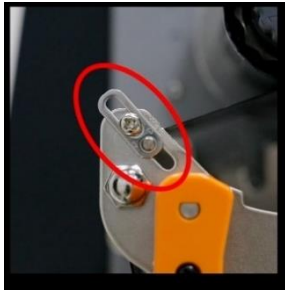

For Ribbon Rewind



For Ribbon Supply

4. Also alternatively, if you need to print smaller media, you can use the latch for the TPH of the printer to secure the small-sized media to prevent printing wrinkles during printing. You can loosen and remove the screw on the right side, move the right cam to the left, and then lock it back using the screw you just removed.



5. Print a test page to check print quality. If the quality is improved, stop the adjustment; if not, continue with next step.
6. If the test print appears as below, remain the screw at the right of Ribbon Bracket fixed, then loose the screw at the left, and gradually fine-tune upward, until the print quality gets improved.



If the test print appears as Figure B, remain the screw at the left of Ribbon Bracket fixed, and then loose the screw at the right, and gradually fine-tune upward, until the print quality gets improved.



## 5.2.4 Small-size Media Offset Adjustment

To print on small media sizes, place the media against the media guide, as shown in the red circle below, to prevent the media from snaking or shifting.

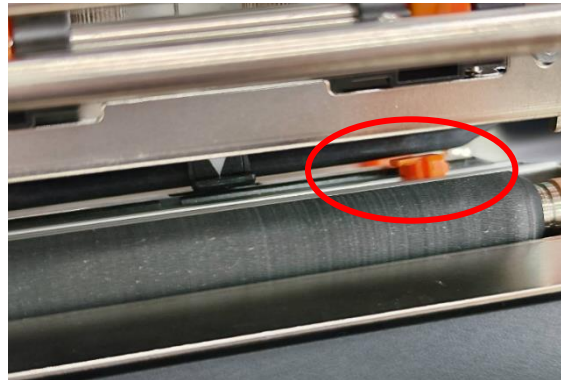

## 5.3 RTC Timer Battery Replacement

RTC stands for Real Time Clock. It is a battery-powered clock that keeps track of the current date and time. If your printer has a built-in RTC timer, you'll find the RTC timer battery on the main circuit board. The RTC timer battery keeps the RTC timer running even when the printer is turned off. When the battery is low or dead, you will need to replace it with a new one.

To replace the RTC timer battery:

1. Turn off the printer and open the left side panel of the printer.
2. Locate the battery next to the main board (attached to the casing).
3. Disconnect the old button battery's power connector from the BT1 slot on the main board, and then remove the button battery from the casing.
4. Attach one side of the new button battery (with tape) to the casing near the main board, and then insert the battery's power connector into the BT1 slot on the main board.
5. Turn on the printer.

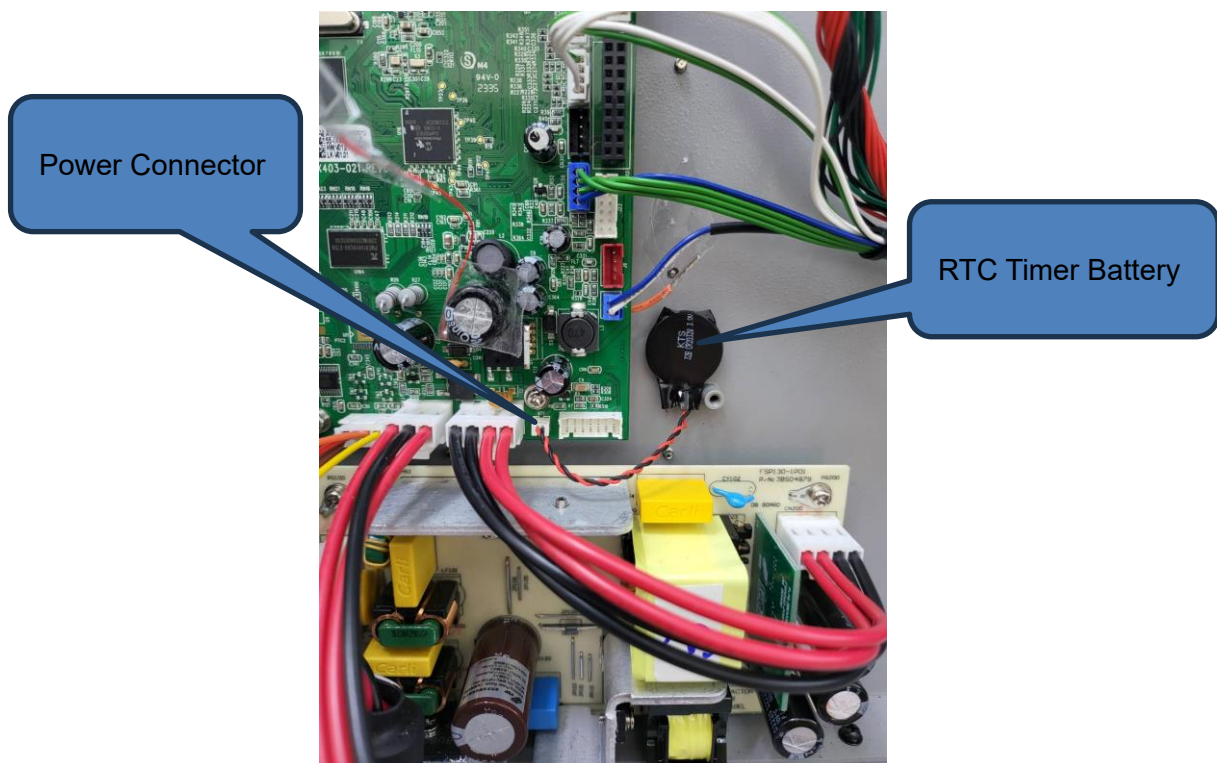

### **CAUTION:**

Risk of explosion if battery is replaced by an incorrect type. Dispose of used batteries according to the instructions.

# 6 Troubleshooting

This chapter provides the information about printer problems and solutions.

## 6.1 Printer issues

### **The printer won't turn on.**

- Did you attach the AC power cord?
- Check the power connection from the wall socket to the printer. Test the power cord and the socket with other electrical devices.
- Disconnect the printer from the wall socket and connect it again.

### **The printer turns itself off.**

- Turn on the printer again.
- If the printer keeps turning itself off, check the socket and make sure it has enough power for the printer.

### **The printer does not feed the media out.**

- The media is not loaded correctly. See Section 2.3, Loading Media, to reload the media.
- If there is a paper jam, clear it.

## 6.2 Media issues

### **The media is out.**

- Load a new media roll.

### **The paper is jammed.**

- Open the printer and clear the jammed paper.
- Make sure the paper is held properly by the **Media Guides**.

### **The printing position is not correct.**

- Did you use the correct media type for printing?
- The media is not loaded correctly. See Section 2.3, Loading Media, to reload the media.
- The media sensor needs to be calibrated. See Section 3.2, Printing Media Calibration & Configuration, to calibrate the sensor.
- The media sensor is dirty. Clean the media sensor.

### **Nothing is printed.**

- The media is not loaded correctly. See Section 2.3, Loading Media, to reload the media.
- The print data might not be sent successfully. Make sure the interface is set correctly in the printer driver and send the print data again.
- Make sure the media and ribbon are both matched.

### **The print quality is poor.**

- The printhead is dirty. Clean the printhead.
- The platen roller is dirty. Clean the platen roller.
- Adjust the print darkness or lower the print speed.
- The media is incompatible for the printer. Use appropriate media roll instead.

## 6.3 Ribbon issues

### **The ribbon is out.**

- Load a new ribbon roll.

### **The ribbon is broken.**

- Check the print darkness and adjust it if it is too high, and take the following steps to fix the broken ribbon:
  1. Unload the ribbon supply roll and take-up roll from the printer.
  2. Pull the ribbon from the supply roll so it overlaps the broken end of the take-up roll.
  3. Tape the overlapped parts together.
  4. Reload both rolls into the printer.

### **The ribbon is “printed out” with the media.**

- The ribbon is not loaded correctly. See Section 2.4, Loading Ribbon, to reload the ribbon.
- The printhead temperature is too high. Reload the ribbon and print a configuration label to check the settings (See Section 3.2, Printing Media Calibration & Configuration). If the print darkness is very high, adjust it in printer preference, or reset your printer (see Section 3.3, Resetting to Factory Default Setting).

### **The ribbon is wrinkled.**

1. Make sure the ribbon is loaded correctly.  
Rotate Thumb Wheel of Ribbon spindles to straighten the ribbon.

## 6.4 Other issues

### **There are broken lines in the printed label.**

- The printhead is dirty. Clean the printhead.

### **The printhead temperature is extremely high.**

- The printhead temperature is controlled by the printer. If it is extremely high, the printer will stop printing automatically, until the printhead is cool down. After that, the printer will resume printing automatically, if there is any unfinished print job.

### **The printhead is broken.**

- Contact your local dealer for assistance.



# 7 Specifications

This chapter provides specifications for the printer.

## 7.1 Printer

Printing Method	Direct Thermal/Thermal Transfer
Printing Resolution	203 dpi (8 dots/mm)
Printing Speed	Max. 12ips (304.8mm/s)
Printing Length	200" (2540mm)
Printing Width	Max 4.09" (104mm)
Memory	128MB DRAM, 128MB Flash
CPU Type	32 bit RISC microprocessor
Sensors	Reflective sensor *1, Transmissive sensor *1
LCD	3.5" Color LCD
Operation Interface	LED indicator x 3, Button x 7
Comm. Interface	Ethernet, USB device, RS-232, USB host
Fonts	Internal character sets standard 5 alpha-numeric fonts from 0.049"H ~ 0.23" H (1.25mm ~ 6.0mm) All fonts expandable up to 24x24 4 direction 0 ~ 270 rotation Soft fonts downloadable (up to 72 points)
Graphics	PPLA: PCX, BMP, IMG, HEX,GDI; PPLB: PCX, BMP, Binary raster, GDI; PPLZ: GRF, Hex, GDI
Emulation	PPLA / PPLB / PPLZ
Software	BarTender, ArgoxBar Pro, Printer Tool, Font Utility
Optional Items	Peeler, Guillotine cutter, Rotary cutter, Internal rewinder, External label rewinder, External media stacker, GPIO module WiFi Module
Agency Listing	CE, CB, FCC, cULus, CCC, BSMI, RoHS



**Note** Print quality and speed is based on 15% print coverage.

## 7.2 Media & Ribbon

Properties	Description
<b>Media Size</b>	Max. width: 4.4" (112mm) Min. width: 1" (25.4 mm) Thickness: 0.0025" ~ 0.01" (0.0635mm ~ 0.254mm) 8.26" (210mm) OD on a 3" (76mm) ID core 7" (177.8mm) OD on a 1.5" (38mm) ID core Min. width 2.3" (58mm) for partial cutter options Min. length 1" (25.4mm) for cutter options
<b>Media Type</b>	Roll-feed, die-cut, continuous, fan-fold, black mark, tags, ticket in thermal paper or plain paper
<b>Ribbon Size</b>	Width: 1" ~ 4" (25.4 mm ~ 101.6 mm) Length: max 450m Wax, 450m Semi-Resin Max OD 3.2" (81.3 mm) Core size ID 1" (25.4 mm)
<b>Ribbon Type</b>	Wax, Semi-wax and Semi-resin, Full resin (both inside-rolled and outside-rolled ribbons are applicable.)

## 7.3 Electrical and operating environment

Properties	Description
<b>Power Supply</b>	Voltage: AC 100 V ~ 240 V $\pm$ 10 % (full range) Frequency: 50 Hz - 60 Hz $\pm$ 5 %
<b>Temperature</b>	Operation: 40°F ~ 104°F (4°C ~ 40°C) Storage: -4°F ~ 122°F (-20°C ~ 50°C)
<b>Humidity</b>	Operation: 25 %RH ~ 85 %RH (non-condensing) Storage: 10 %RH ~ 90 %RH (non-condensing)

## 7.4 Physical dimension

Dimension	Size and Weight
Size	W 250mm x H 260mm x L 390 mm
Weight	13 kg (28.66lbs)



**Note** The specifications may be changed at any time without prior notice. For more information about the new specifications, visit Argox website or contact your dealer.

## 7.5 Fonts, Barcodes, and Graphics Specification

The specifications of fonts, bar codes and graphics depends on the printer emulation. The emulations PPLA, PPLB, and PPL Z are printer programming languages, through which the host can communicate with your printer.

### Printer Programming Language PPLA

Programming Language	PPLA
Internal fonts	9 fonts with different point size 6 fonts with ASD smooth font. Courier font with different symbol sets.
Symbol sets (Code pages)	Courier font symbol set: Roman-8, ECMA-94, PC, PC-A, PC-B, Legal, and PC437 (Greek), Russian.
Soft fonts	Downloadable soft fonts by Print Tool
Font size	1x1 to 24x24 times
Character rotation	0, 90, 180, 270 degree, 4 direction rotation
Graphics	PCX, BMP, IMG, GDI and HEX format files
1D Barcodes	Code 39, UPC-A, UPC-E, Code 128 subset A/B/C, EAN-13, EAN-8, HBIC, Codabar, Plessey, UPC2, UPC5, Code 93, Postnet, UCC/EAN-128, UCC/EAN-128 K-MART, UCC/EAN-128 Random weight, Telepen, FIM, Interleaved 2 of 5 (Standard/with modulo 10 checksum/ with human readable check digit/ with modulo 10 checksum & shipping bearer bars), GS1 Data bar (RSS)

Programming Language	PPLA
2D Barcodes	MaxiCode, PDF417, Data Matrix (ECC 200 only), QR code, Composite Codes, Aztec

## Printer Programming Language PPLB

Programming Language	PPLB
Internal fonts	5 fonts with different point size
Symbol sets (Code pages)	8 bits code page : 437, 850, 852, 860, 863, 865, 857, 861, 862, 855, 866, 737, 851, 869, 1252, 1250, 1251, 1253, 1254, 1255 7 bits code page: USA, BRITISH, GERMAN, FRENCH, DANISH, ITALIAN, SPANISH, SWEDISH, and SWISS
Soft fonts	Downloadable soft fonts by Print Tool
Font size	1x1 to 24x24 times
Character rotation	0, 90, 180, 270 degree, 4 direction rotation
Graphics	PCX, Binary Raster, BMP, and GDI
1D Barcodes	Code 39, UPC-A, UPC-E, Matrix 2 of 5, UPC-Interleaved 2 of 5, Code 39 with check sum digit, Code 93, EAN-13, EAN-8 (Standard, 2/5 digit add-on), Codabar, Postnet, Code 128 subset A/B/C, Code 128 UCC (shipping container code), Code 128 auto, UCC/EAN code 128 (GS1-128), Interleave 2 of 5, Interleaved 2 of 5 with check sum, Interleaved 2 of 5 with human readable check digit, German Postcode, Matrix 2 of 5, UPC Interleaved 2 of 5, EAN-13 2/5 digit add-on, UPCA 2/5 digit add-on, UPCE 2/5 digit add-on, GS1 Data bar (RSS)
2D Barcodes	MaxiCode, PDF417, Data Matrix (ECC 200 only), QR code, Composite Codes, Aztec

## Printer Programming Language PPLZ

Programming Language	PPLZ
Internal fonts	8 (A~H) fonts with different point size.
	8 AGFA fonts: 7 (P~V) fonts with fixed different point size (not scalable)
	1 (O) font with scaling point size.
Symbol sets (Code pages)	USA1, USA2, UK, HOLLAND, DENMARK/NORWAY, SWEDEN/FINLAND, GERMAN, FRANCE1, FRANCE2, ITALY, SPAIN, MISC, JAPAN, IBM850, Multibyte Asian Encodings, UTF-8, UTF-16 Big-Endian, UTF-16 Little-Endian, Code page 1250, 1251, 1252, 1253, 1254
Soft fonts	Downloadable soft fonts by Print Tool
Font size	1x1 to 10x10
Character rotation	0, 90, 180, 270 degree, 4 direction rotation
Graphics	GRF, Hex, and GDI
1D Barcodes	Code39, UPC-A, UPC-E, Postnet, Code128 subset A/B/C, Interleave 2 of 5, Interleaved 2 of 5 with check sum, Interleaved 2 of 5 with human readable check digit, Code 93, Code 39 with check sum digit, MSI, EAN-8, Codabar, Code 11, EAN-13, Plessey, GS1 Data bar (RSS), Industrial 2 of 5, Standard 2 of 5, Logmars
2D Barcodes	MaxiCode, PDF417, Data Matrix (ECC 200 only), QR code, Composite Codes, Aztec

## 7.6 Interfaces

This section provides information about IO port specifications for the printer.

### 7.6.1 USB

There are two common USB connectors. Typically, type A is found on hosts and hubs; type B is found on devices. The figure below shows their pinouts.

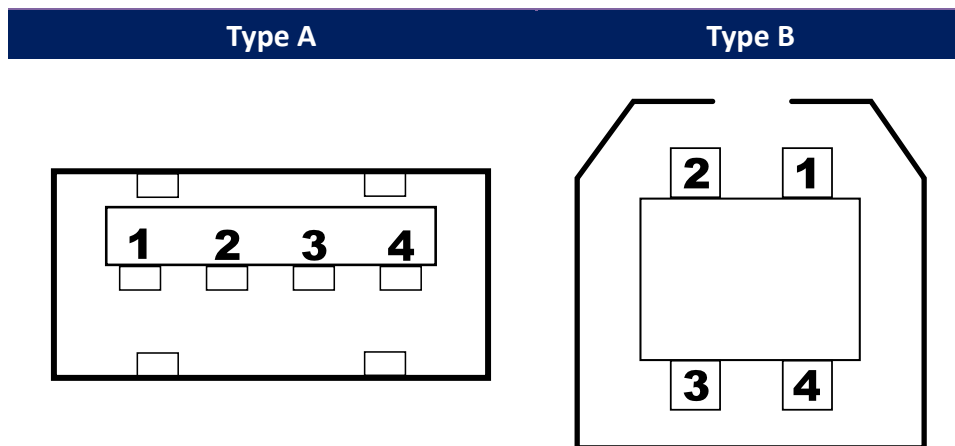

Pin	Signal	Description
1	VBUS	+5V
2	D-	Differential data signaling pair -
3	D+	Differential data signaling pair +
4	Ground	Ground

## 7.6.2 RS-232C

The RS-232C on the printer is DB9 female. It transmits data bit by bit in asynchronous start-stop mode. The figure below shows its pinout.

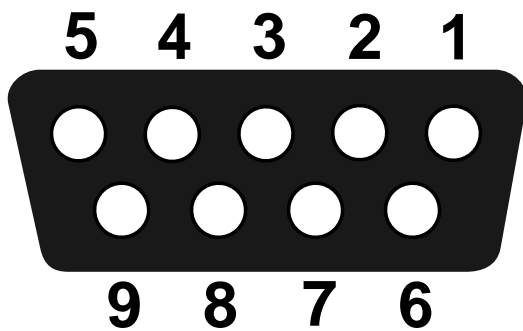

Pin	Signal	Description
1	NA	No Function
2	TxD	Transmit
3	RxD	Receive
4	NA	No Function
5	GND	Ground
6	NA	No Function
7	CTS	Clear to Send
8	RTS	Request to Send
9	NC	No Connection

Host (DB9)			Printer (DB9)		
Signal	Description	Pin	Pin	Description	Signal
CD	Carrier Detect	1	1	No Function	NC
RxD	Receive	2	2	Transmit	TxD
TxD	Transmit	3	3	Receive	RxD
DTR	Data Terminal Ready	4	4	No Function	NC
GND	Ground	5	5	Ground	GND
DSR	Data Set Ready	6	6	No Function	NC
RTS	Request to Send	7	7	Clear to Send	CTS
CTS	Clear to Send	8	8	Request to Send	RTS
CI		9	9	No Function	NC

## 7.6.3 GPIO

The input and output definitions are shown below.

DB15 Pin No.	Direction (Power/In/Out)	Name	Port No.
1	P	GND	X
2	P	5V	X
3	Input	Start Print	CS4 bit0
4	Input	Feed	CS4 bit1
5	Input	Pause	CS4 bit2
6	Input	Reprint	CS4 bit3
7	P	24V	X
8	P	GND	X
9	NC	NC	X
10	Output	Serv_Req	PC18
11	Output	End_Print	PB21
12	Output	Meida Out	PC17
13	Output	Ribbon Out	PC18
14	Output	Data Ready	PC16
15	Output	OPT_Fault	PA25

Initialize:

- (1) During initialize process, please set all of output port to high for status clear, it mean all of outputs are active low.
- (2) The active level may need to be customized.
- (3) The input normal state (idle) is high level, so all of the inputs are also active low.



## 7.6.4 Ethernet

The Ethernet uses RJ-45 cable, which is 8P8C (8-Position 8-Contact). The figure below shows its pinout.

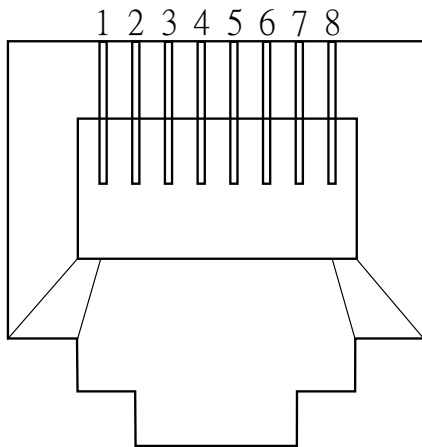

Pin	Signal
1	Transmit+
2	Transmit-
3	Receive+
4	Reserved
5	Reserved
6	Receive-
7	Reserved
8	Reserved