

CW-C6000 Series

CW-C6500 Series

User's Guide

Before use

Basic Operation

Maintenance

Troubleshooting

Specifications

Appendix

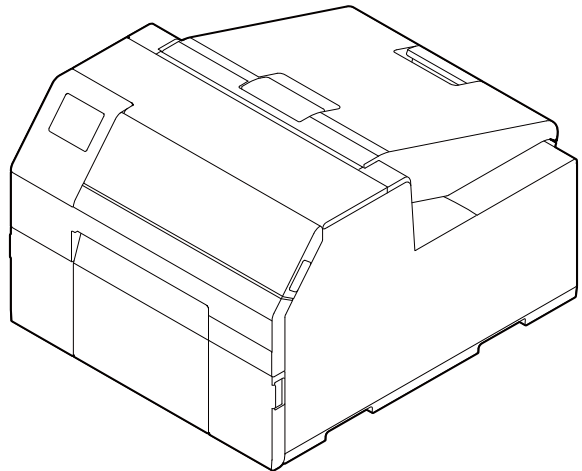
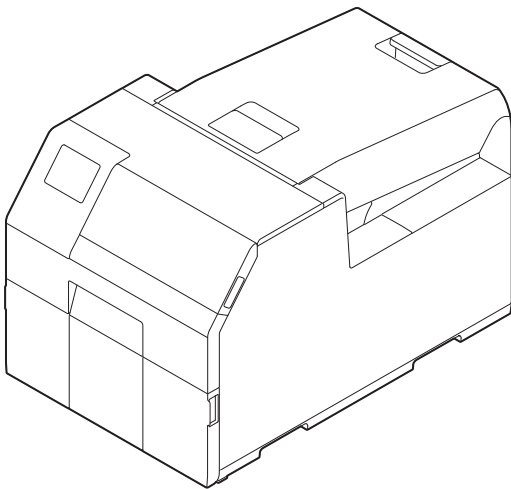

 ["Loading and Replacing Paper" on page 41](#)

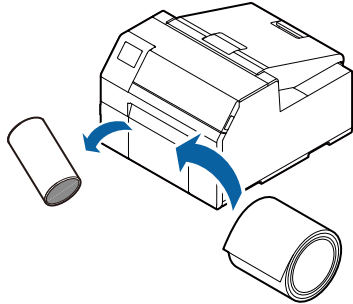

 ["Replacing the Ink Cartridges" on page 31](#)

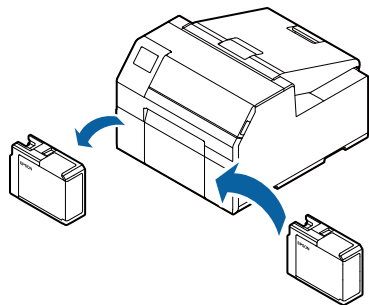

 ["Troubleshooting" on page 66](#)



Before use 4

■ Manuals for This Product.....	4
Downloading the Latest Version.....	4
Symbols Used in This Guide.....	5
■ About Models of this Product.....	6
Auto Cutter Model.....	6
Peeler Model.....	6
Gloss Black Ink/Matte Black Ink.....	7
■ Software Introduction.....	7
■ Product and Driver Versions.....	8
How to Check the Product Version.....	8
How to Check the Printer Driver Version.....	8
■ Screens in This Manual.....	9
■ Product Illustrations.....	9
■ Safety Precautions.....	10
Cautions on Installation.....	10
Cautions on Handling.....	10
Cautions on Power Supply.....	12
Cautions on Ink Cartridges.....	13
Cautions on the Maintenance Box.....	15
Caution Label.....	15
■ Paper That Can Be Used.....	17
Paper Shapes.....	17
Forms of Paper.....	17
List of Paper That Can Be Used.....	18
Paper That Cannot Be Used.....	19
■ Part Names and Functions.....	20
Front.....	20
Rear.....	21
Inside.....	22
Spindle and Flange.....	23
Operation Panel.....	24

Basic Operation 26

■ Turning On/Off.....	26
Turning the Power On.....	26
Turning the Power Off.....	26
■ Opening the Paper Cover.....	27
Opening the Cover using the Lever in the Front.....	27
Opening the Cover using the Lever in the Back.....	27
■ Checking the Printer Status.....	28
Checking the Paper Information.....	28
Checking the Status of Consumables.....	29
Printing Nozzle Check Patterns.....	29
Printing Status Sheet.....	30

Checking Network Connection and Settings.....	30
■ Replacing the Ink Cartridges.....	31
Checking Amount of Ink Remaining	31
How to Replace the Ink Cartridges	32
■ Replacing the Maintenance Box	33
Checking the Amount of Empty Space in the Maintenance Box	33
How to Replace the Maintenance Box.....	34
■ Printer Driver Settings	35
■ Loading and Replacing Paper.....	41
How to Load Paper (Auto Cutter Model - Supply from Inside)	42
How to Load Paper (Auto Cutter Model - Supply from Outside).....	45
How to Load Paper (Peeler Model - Supply from Inside)	48
How to Remove Paper (For the Auto Cutter Model)	52
How to Remove Paper (For the Peeler Model)	53
How to Eject Paper at Paper End (For the Auto Cutter Model).....	54
How to Eject Paper at Paper End (For the Peeler Model)	55

Maintenance..... 56

■ Cleaning the Exterior	57
■ Cleaning the Auto Cutter (Auto Cutter Model Only)	58
■ Cleaning the Peeler (Peeler Model Only).....	59
■ Cleaning the Edge Guides.....	60
■ Cleaning the Platen	61
■ Cleaning the Paper Feed Roller	62
■ Cleaning the Paper Pressure Roller.....	63
■ Cleaning the Print Head.....	64
Using the Operation Panel.....	65
Using the Printer Driver.....	65
Using the WebConfig.....	65

Troubleshooting 66

■ Paper is jammed	66
For the Auto Cutter Model	67
For the Peeler Model	69

■ Problems with Print Quality	71
Horizontal White Banding	71
Vertical White Spots (Auto Cutter Model)	71
White or Black Banding.....	71
Printed Colors Are Wrong	72
Print Position Shifts	72
Paper is Smeared or Smudged with Ink.....	72
Paper is Fed and Ejected, and an Error Occurs	72
■ Printing is Impossible or Becomes Suddenly Impossible	73
Print Data is Sent, But Does Not Print (Peeler Model)	73
■ Printing from a computer is impossible or becomes suddenly impossible	73
Checking Whether the Printer Driver Is Installed	73
The printer does not turn on	73
Print Job is Canceled on PC but "Printing" Message on Printer Does Not Disappear	73
■ A Message is Displayed on the Operation Panel	74

Specifications 78

■ Specification.....	78
Electrical Specifications	80
Overall Dimensions	80
■ Environmental Specifications	81
■ Paper Specifications	82
■ Ink Cartridge	83
■ Maintenance Box.....	84

Appendix 85

■ Consumables and Options	85
Ink Cartridge	85
Maintenance Box	86
Roll Paper Holder	87
■ Restriction of Use	88
■ Notes.....	88
■ Trademarks	88

Before use

This chapter describes information you should know before using the product.

Manuals for This Product

Paper manual



Start Here

Guides you through basic setup steps from unpacking to loading paper.

Manual viewable with PC



User's Guide (This Manual)

Describes details about the functions and operating procedures of the product, maintenance information, and troubleshooting.

Manual viewable with PC



CW-C6000 Series/CW-C6500 Series Technical Reference Guide

Provides information necessary for installing the product, performing daily tasks, and developing a system using the product. Download this document from the following URL.
<<https://www.epson-biz.com/>>

Manual viewable with PC



Online Video Manual

Provides videos that show you operating procedures and troubleshooting information. Access the videos from the following URL.
<https://support.epson.net/p_doc/790/>
The contents of videos are subject to change without notice.

Downloading the Latest Version

The latest versions of the printer driver, utilities, and manuals can be downloaded from the following URL.



<<https://www.epson-biz.com/>>

Symbols Used in This Guide



The following symbols are used in this guide to indicate important information.

Symbols for Safety

The symbols shown below are used in this manual in order to ensure safety and proper use of this product and to prevent danger to you and other persons, and property damage. Be sure that you completely understand their meanings before reading this manual.

 WARNING	Handling the product improperly by ignoring this symbol can lead to death or serious injury.
 CAUTION	Handling the product improperly by ignoring this symbol can lead to injury and property damage.

Symbols for General Information

 IMPORTANT	Indicates information with which you must comply when using the product. Mishandling due to ignoring this information may cause the product to fail or malfunction.
 NOTE	Indicates supplementary explanations and information you should know.
	Indicates a reference page containing related information.

About Models of this Product

Auto Cutter Model

Features: Equipped with an auto cutter. The paper can be cut either according to the application settings, or with the help of the Cut button on the operation panel.

Model number:

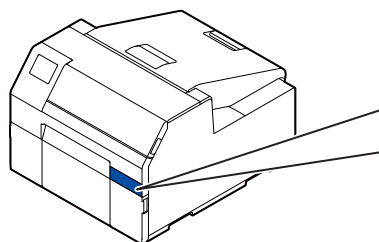

CW-C6000 Series (4-inch model)

ColorWorks C6000Au, ColorWorks C6000Ae,
ColorWorks C6010A, ColorWorks C6020A,
ColorWorks C6030A, ColorWorks C6040A,
ColorWorks C6050A

CW-C6500 Series (8-inch model)

ColorWorks C6500Au, ColorWorks C6500Ae,
ColorWorks C6510A, ColorWorks C6520A,
ColorWorks C6530A, ColorWorks C6540A,
ColorWorks C6550A

Peeler Model

Features: Equipped with a peeler mechanism. By passing a backing paper through the peeler, labels are printed being peeled from the backing paper.

Model number:

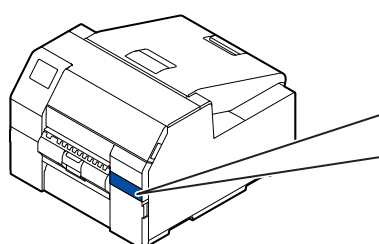

CW-C6000 Series (4-inch model)

ColorWorks C6000Pu, ColorWorks C6000Pe,
ColorWorks C6010P, ColorWorks C6020P,
ColorWorks C6030P, ColorWorks C6040P,
ColorWorks C6050P

CW-C6500 Series (8-inch model)

ColorWorks C6500Pu, ColorWorks C6500Pe,
ColorWorks C6510P, ColorWorks C6520P,
ColorWorks C6530P, ColorWorks C6540P,
ColorWorks C6550P

Gloss Black Ink/Matte Black Ink

You can select either gloss black (BK) and matte black (MK) for the type of black ink you want to use. The printer prompts you to select it when you turn on the printer for the first time.

Supported paper types vary by the black ink type. See ["Paper Specifications" on page 82](#).



IMPORTANT

You cannot change the black ink type once you select the black ink type and let the printer charge the ink.

Software Introduction

The following introduces the software that can be used with the product.

Name	Overview
Printer driver	Driver to print from Windows applications. The utility (CW-C6000 Series/CW-C6500 Series PrinterSetting) for configuring the printer settings can be started from the driver. For details on how to use the driver, refer to Help or the video.
EpsonNet Config	Tool to acquire or set network settings, such as TCP/IP of the product.
Color Tone Matching Assistant	Assists you to adjust colors of illustrations or letters. You can check how a specific color used in illustrations or letters will look on printouts.

Product and Driver Versions

Use a combination of the latest versions of the product firmware, printer driver, and utility.

In particular, if the firmware version is one of the following versions, download the latest version of the firmware and update the printer using the latest one.

TS05JC, TS06JC, TS26JC, TS19K2, TS25K3, TS21K5

To get the latest version of software, see ["Downloading the Latest Version" on page 4](#).

How to Check the Product Version

You can check the version of your product firmware by printing the status sheet. Check the results of status sheet printing. ([↶ "Printing Status Sheet" on page 30](#))

You can also check the version on the operation panel.

[Menu] - [Printer Status/Print] - [Firmware Version]

How to Check the Printer Driver Version

You can check the version in the printer driver screen.

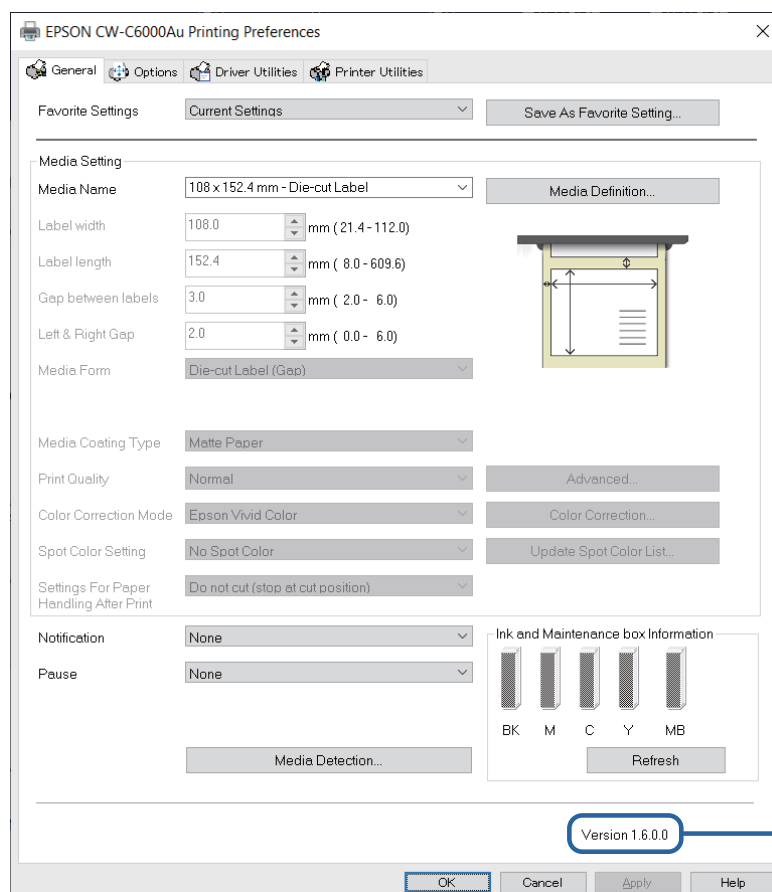

Printer driver
version

Screens in This Manual

The screens in this manual and the screens actually displayed in Windows may differ depending on the product used and operating system. Unless otherwise specified, the screens in this manual are those when using Windows 10.



Product Illustrations

The product illustrations used throughout this manual may slightly differ from the product you are using. Unless otherwise stated, illustrations of CW-C6500 Series are used.

Safety Precautions



To ensure safe use of the product, be sure to read this manual and the other instruction manuals supplied with the product before use. Store this manual in a safe place so that you can resolve any unclear points regarding the product at any time.

Cautions on Installation



 WARNING	<p>Do not block the air vents of the product. (👉 "Rear" on page 21) Doing so can result in heat accumulated in the product causing a fire. Do not cover the product with a cloth or install it in a poorly-ventilated location. Furthermore, ensure there is the installation space specified in the manual.</p>
 CAUTION	<p>Do not install/store the product in an unstable location or in a location subject to vibration from other devices. Equipment may fall or collapse, causing breakage and possible injury.</p> <p>Do not install the product in a location exposed to oily smoke or dust, or in a humid location. Doing so may cause electric shock or fire.</p> <p>When lifting the product, perform the work with the correct posture. Lifting the product with an inappropriate posture may cause injury.</p> <p>This is a heavy product. Therefore, make sure it is not carried by a single person. Ensure that two or more people carry this product during unpacking or shifting. See below for details on the mass of this product. (👉 "Specifications" on page 78)</p> <p>Do not install this product at a location exposed to strong light such as direct sun rays. Doing so may cause the detector to malfunction and the printer may not print properly.</p>

Cautions on Handling



 WARNING	<p>Do not use the product in a location with volatile substances such as alcohol or paint thinner present, or near fire. Doing so may cause electric shock or fire.</p> <p>Shut down the product immediately if it produces smoke, a strange odor, or unusual noise. Doing so may cause electric shock or fire. If an abnormality occurs, immediately turn off the power and remove the plug from the outlet, and then contact qualified service personnel for advice.</p>
---	---

 WARNING	<p>Shut down the product immediately if a foreign object or water or other liquid gets inside the product. Doing so may cause electric shock or fire. Immediately turn off the power and remove the plug from the outlet, and then contact qualified service personnel for advice.</p>
	<p>Do not disassemble the areas other than those mentioned in this manual.</p>
	<p>Never repair the product yourself as doing so is dangerous.</p>
	<p>Do not use the product in a location where inflammable gas, explosive gas, etc. is present in the atmosphere. Furthermore, do not use aerosol sprayers containing flammable gas inside or around the product. Doing so may cause fire.</p>
	<p>Do not connect cables in ways other than those mentioned in this manual. Doing so may cause fire. It may also damage the other connected devices.</p>
	<p>Do not touch the areas inside the product other than those mentioned in this manual. Doing so may cause electric shock or burns.</p>
	<p>Do not insert metal or flammable materials, or allow them to fall into the product. Doing so may cause electric shock or fire.</p>
	<p>If the screen of the printer is damaged, handle the liquid crystal inside it very carefully. Should any of the following situations arise, take emergency measures.</p> <ul style="list-style-type: none"> * When any part gets onto your skin, wipe off the deposit, and wash the area properly with soap and water. * When any part gets into your eyes, flush them with clean water for at least 15 minutes, and thereafter, consult with a doctor. * When a part gets into your mouth, immediately consult with a doctor.
 CAUTION	<p>Do not allow anyone to stand or place heavy objects on top of the product. In particular, be careful in the case of a household with children. Equipment may fall or collapse, causing breakage and possible injury.</p>
	<p>Install the cables and optional products in the proper direction according to the proper procedures. Doing so may cause fire or injury. Follow the instructions in this manual to install them properly.</p>
	<p>Before moving the product, shut down and unplug the product, and make sure that all the cables are disconnected. Failure to do so may damage a cable, causing electric shock or fire.</p>
	<p>Do not store or transport the product while it is tilted, standing, or upside down. Doing so may cause the ink to leak.</p>
	<p>Do not remove the paper cover when using the product. Doing so may result in normal operation and printing becoming no longer possible.</p>

Cautions on Power Supply

 WARNING	<p>Do not allow dust or other foreign material to adhere to the power plug. Doing so may cause electric shock or fire.</p>
	<p>Do not use a power cord other than that supplied with the product. In addition, do not use the supplied power cord with another device. Doing so may cause electric shock or fire.</p>
	<p>Do not use a damaged power cord. Doing so may cause electric shock or fire. Contact qualified service personnel for advice if the power cord is damaged. Furthermore, observe the following points so as not to damage the power cord.</p> <ul style="list-style-type: none"> * Do not modify the power cord. * Do not place heavy objects on the power cord. * Do not forcibly bend, twist, or pull the power cord. * Do not lay the power cord near a heating appliance.
	<p>Do not insert or remove the power plug with a wet hand. Doing so may cause electric shock.</p>
	<p>Do not connect many power cords to one outlet. Doing so may cause fire. Supply power directly from a power outlet.</p>
	<p>Regularly disconnect the power plug from the outlet and clean the base of the prongs and between the prongs. Leaving the power plug connected to the outlet for a long period of time may cause dust to accumulate on the base of the power plug prongs, resulting in a short and fire.</p>
	<p>Hold the plug and do not pull the cord when disconnecting the power plug from the outlet. Pulling the cord may damage the cord or deform the plug, causing electric shock or fire.</p>
 CAUTION	<p>To ensure safety, unplug the product before leaving it unused for an extended period.</p>

Cautions on Ink Cartridges

 CAUTION	<p>The ink cartridges that can be used differ depending on the model number of the product. Use ink cartridges suitable for the model number of your printer. ( "Ink Cartridge" on page 85)</p>
	<p>Do not touch the IC chip on an ink cartridge. Doing so may result in normal operation and printing becoming no longer possible.</p>
	<p>The product uses ink cartridges equipped with IC chips to manage the amount of ink used and other information so ink cartridges are usable even if they are removed and reinstalled. However, if an ink cartridge with not much ink remaining is removed and reinstalled, it may not be usable. Some ink is consumed each time cartridges are installed because the product automatically checks their reliability.</p>
	<p>When replacing the black ink cartridge, make sure to replace with a cartridge of the same type of black ink. The printer does not work if you install a cartridge of different type of black ink.</p>
	<p>Install all ink cartridges. Printing is not possible if even only one ink cartridge is missing.</p>
	<p>Since ink cartridges are designed to stop the operation before ink runs out completely to maintain the quality of the print head, some ink remains in the used ink cartridges.</p>
	<p>All the ink colors are consumed also for the maintenance operations when an ink cartridge is replaced and for print head cleaning.</p>
	<p>Do not turn off the power or open the ink cartridge cover during ink charging (while the  (power) LED lamp is flashing). Opening the cover may cause the ink to be recharged, resulting in more ink being consumed. Also, it may result in normal printing becoming no longer possible.</p>
	<p>Even for monochrome printing, all the ink colors are used in an operation designed to maintain the printing and print head quality.</p>
	<p>Do not disassemble an ink cartridge. Doing so may cause ink to get into eyes or onto skin.</p>
<p>Do not disassemble or modify an ink cartridge. Doing so may cause printing malfunction.</p>	
<p>Use of old ink cartridges may result in reduced print quality. Use ink cartridges up within six months after opening the packages. The usage period for ink cartridges is printed on the packaging of the individual ink cartridges.</p>	

**CAUTION****If ink contacts your skin, eyes, or mouth, take the following actions.**

- * When ink gets onto your skin, immediately wash the area with soap and water.
- * When ink gets into your eyes, immediately flush them with water. Leaving the ink as is may result in bloodshot eyes or mild inflammation. If something is wrong, immediately consult with a doctor.
- * When ink gets into your mouth, immediately spit it out and consult with a doctor.

There may be some ink around the ink supply port on a removed ink cartridge. Take care so that it does not stain the desk or other surface.

Do not open an ink cartridge package until you are ready to install the ink cartridge in the product.



Do not shake an ink cartridge too hard.

The ink cartridge may leak if you shake it around too much or push the sides strongly.

Do not allow foreign objects to fall into the cartridge installation section.

Doing so may result in normal printing becoming no longer possible. Remove any object that falls into the installation section, taking care not to damage the section.

When ink is charged the first time (right after purchase), ink is consumed for filling the print head nozzles (ink discharge holes) to get ready for printing. Therefore, the number of the sheets that can be printed may be fewer than for cartridges installed later.

When the printer is powered off with the  (power) button, the print head is automatically capped to prevent the ink from drying. When you will not use the printer after installing the ink cartridges, be sure to turn the power off with the  (power) button. Do not pull out the power plug or turn off the breaker while the power is on.

Printing on water-repellent paper such as art paper, which is slow-drying, may cause print stains. Also, if you print on glossy paper, fingerprints may get on the paper or ink may adhere to your fingers when you touch the print surface. Select and use paper that will not cause print stains.

Store the ink cartridges in a place out of reach of children.

Epson recommends storing ink cartridges in a cool and dark place.

If you wish to use ink cartridges that have been stored in a cold place for a long period of time, leave them for at least 3 hours in a place that is at room temperature before use.

Do not remove the ink cartridges from the product when storing or transporting the product.

Cautions on the Maintenance Box

 CAUTION	Store in a place out of reach of children. Do not drink any adhered ink.
	Do not disassemble or modify the maintenance box. Doing so may cause ink to get into eyes or onto skin.
	Do not touch the IC chip on the maintenance box.
	If a maintenance box that can still be used has been removed and left detached for a long period of time, do not reuse it.
	Do not peel off the film from the top surface of the maintenance box.
	If ink contacts your skin, eyes, or mouth, take the following actions. <ul style="list-style-type: none"> * When ink gets onto your skin, immediately wash the area with soap and water. * When ink gets into your eyes, immediately flush them with water. Leaving the ink as is may result in bloodshot eyes or mild inflammation. If something is wrong, immediately consult with a doctor. * When ink gets into your mouth, immediately spit it out and consult with a doctor.
	Do not shake a used maintenance box too hard. The ink may leak from the maintenance box if you shake it around too much or push the sides strongly.
	Avoid storing the maintenance box under high temperatures or in a frozen state.
Keep it away from direct sunlight.	

Caution Label

The labels affixed to the product indicate the following cautions.

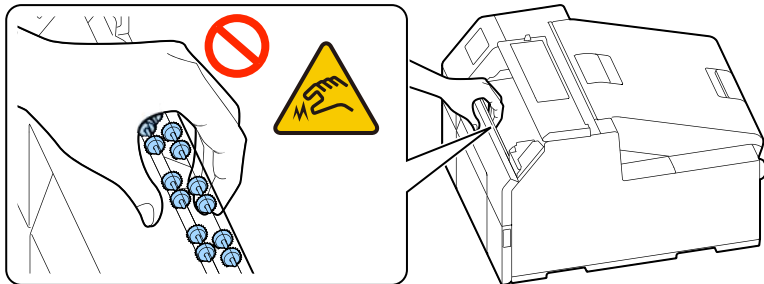
 WARNING	Do not touch the roller at the bottom of the paper holder unit with your hand. Doing so may cause injury.
	

 CAUTION

Do not touch the manual cutter at the bottom of the peeler cover with your hand. Doing so may cause injury.

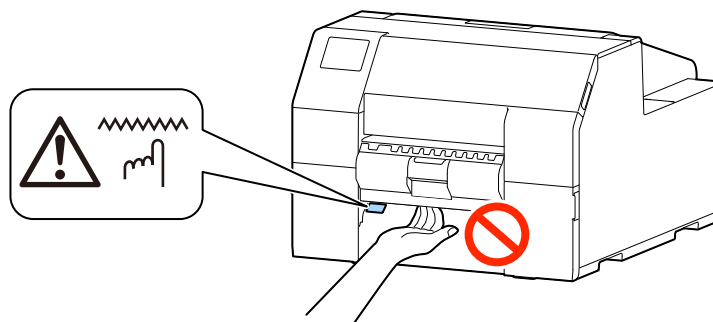

Paper That Can Be Used

The following shapes and forms of paper can be used with the printer.

For the detailed specifications, refer to the CW-C6000 Series/CW-C6500 Series Technical Reference Guide.

Paper Shapes

The following shapes of paper can be used.

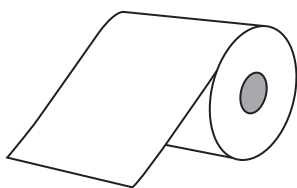

Roll paper

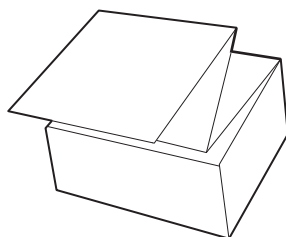

Fanfold paper

Forms of Paper

The following forms of paper can be used.

Continuous paper (without adhesive)

- Continuous paper



Continuous paper without adhesive
(Without black marks)



Continuous paper without adhesive
(With black marks ^{*1})

Label paper (with adhesive)

- Continuous label



Without waste parts and no black marks



With waste parts and no black marks



Without waste parts and with black marks ^{*1}



With waste parts and black marks ^{*1}

- Die-cut label

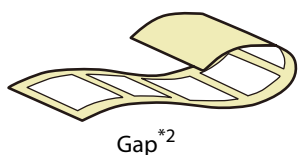

*1: The print position is detected based on the black marks printed on the back of the paper.

*2: The print position is detected based on the gaps between labels.



NOTE

Cautions on printing the continuous label by using the auto cutter model

- Remove the printed labels that are remaining in the paper ejection slot. If you continue with printing while the labels are still remaining in the paper ejection slot, the printed labels may be cut in double, or the paper may be jammed.
- The label adhesive may adhere to the cutter, and deteriorate its cutting ability. If it becomes difficult to cut the paper, it is recommended to clean the auto cutter.
(👉 ["Cleaning the Auto Cutter \(Auto Cutter Model Only\)" on page 58](#))

Cautions on using a die-cut label

Depending on the shape of die-cut labels, the labels may peel off their backing paper inside the printer. In such a case, it is necessary to operate gap detectors. For details on how to operate the detectors, refer to the CW-C6000 Series/CW-C6500 Series Technical Reference Guide.

List of Paper That Can Be Used

Paper shapes	Forms of paper	Paper types
Roll paper	Continuous label (with black marks)	Plain Paper
	Continuous label (without black marks)	Matte Paper
	Die-cut labels (with black marks)	Synthetic
	Die-cut labels (without black marks)	Texture Paper
	Continuous plain paper (with black marks)	Glossy Paper
	Continuous plain paper (without black marks)	Glossy Film
Fanfold paper	Die-cut labels (with black marks)	High Glossy Paper
	Continuous plain paper (with black marks)	

Paper That Cannot Be Used

Do not load paper like the following. Such paper will cause paper jams and print stains.



Thermal paper

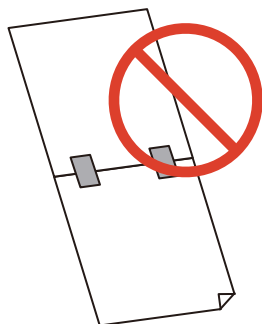

Paper joined together by tape, etc.

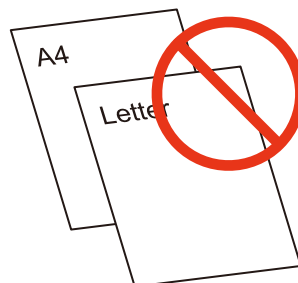

Paper of A size, B size, etc.

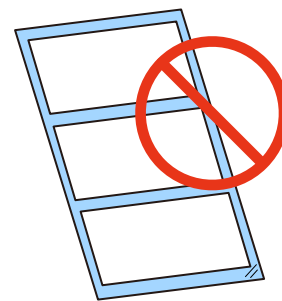

Paper with transparent backing paper

Part Names and Functions

This section describes the main operation parts.

Front

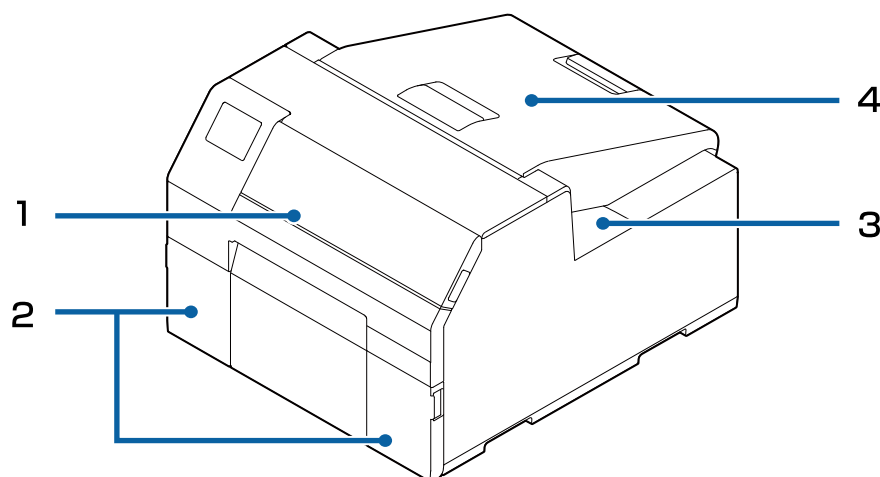

Peeler model

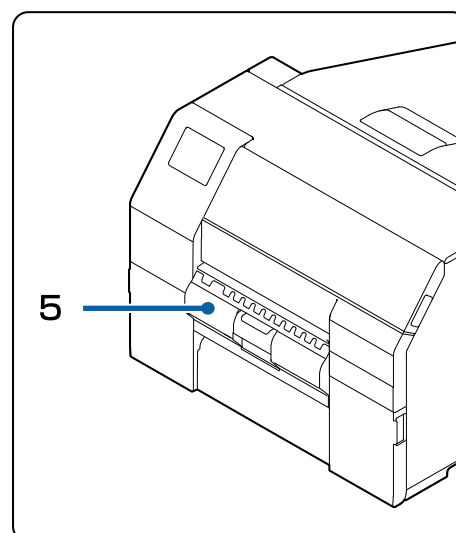

1 Front cover

Open this cover to remove paper if it is jammed.
 (🔗 ["Paper is jammed" on page 66](#))

2 Ink cartridge cover

Open this cover to install/replace the ink cartridge.
 (🔗 ["Replacing the Ink Cartridges" on page 31](#))

3 Maintenance box cover

Open this cover to install/replace the maintenance box.
 (🔗 ["Replacing the Maintenance Box" on page 33](#))

4 Paper cover

Open this cover to load or replace paper. How to open the paper cover differs depending on whether the paper is to be supplied from the inside or the outside.
 (🔗 ["Opening the Paper Cover" on page 27](#))

5 Peeler cover (peeler model only)

Open this cover to load paper. By passing a backing paper through the peeler, labels are printed being peeled from the backing paper. The cover is equipped with a label peeling detector, which detects whether a peeled label is remaining at the paper ejection slot or not.

Rear

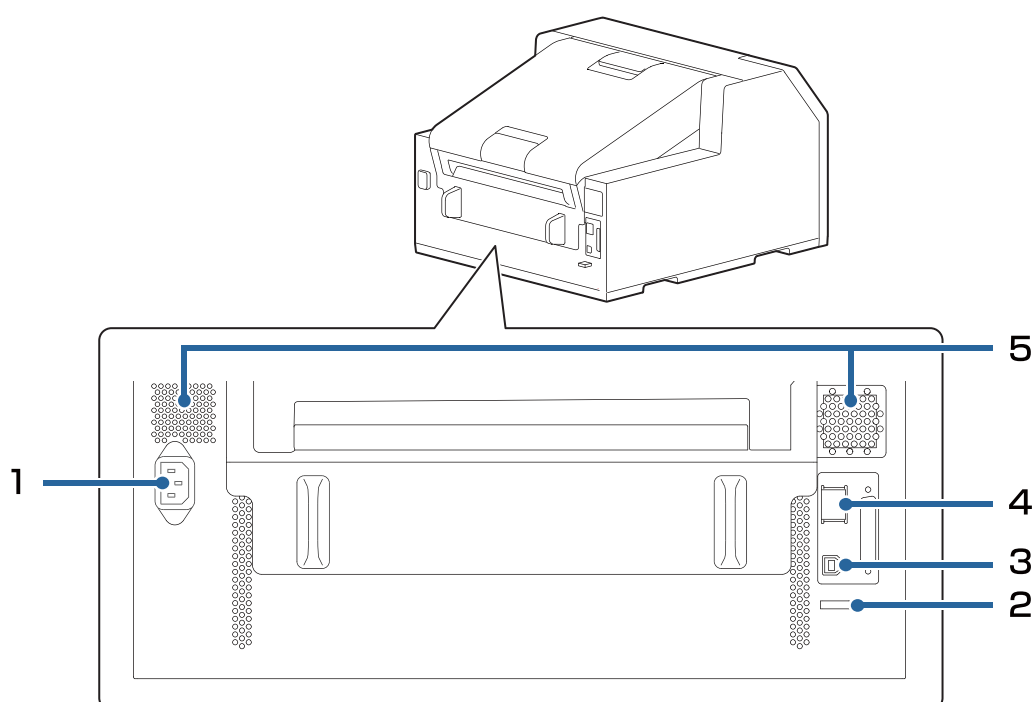
**1 Power connector**

Connect the power cable.

2 Wire saddle

Pass the USB cable through this saddle to prevent disconnection of the cable.

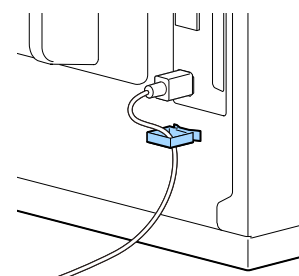
**3 USB port**

Connect a USB cable.

4 LAN port

Connect a LAN cable.

5 Air vent

Exhausts heat generated in the printer to prevent the temperature inside the printer from rising. Provide a clearance of 10 cm {3.94"} or more from the area around the air vent to ensure ventilation when installing the printer.

Inside

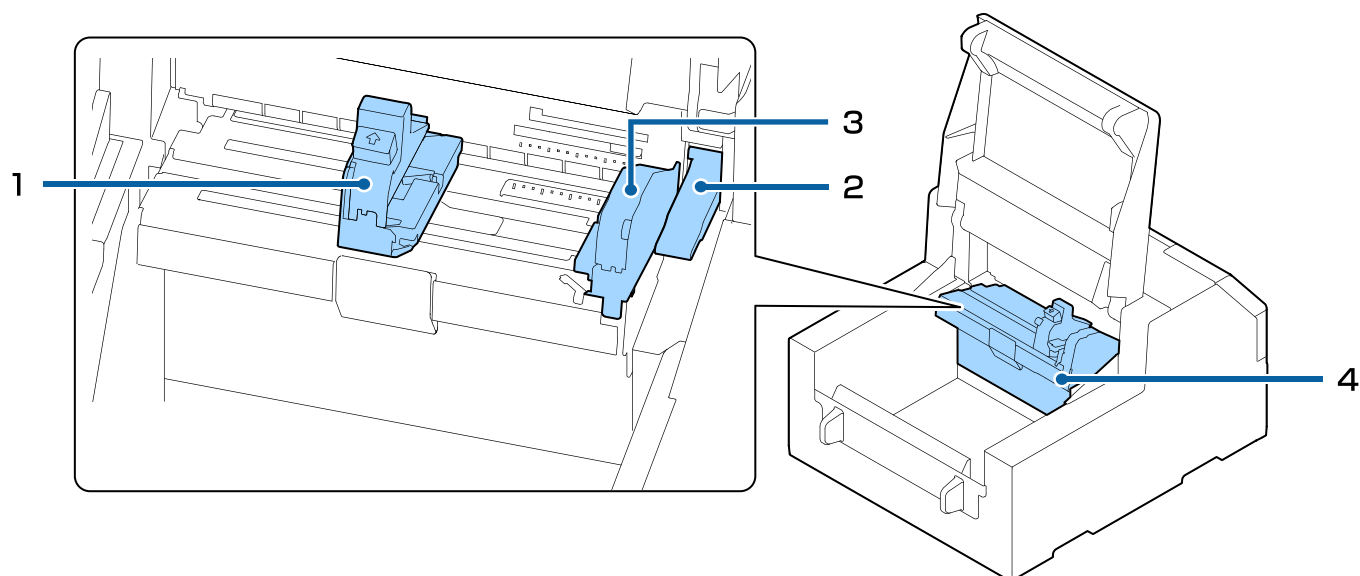

1 Movable edge guide

Supports paper at the paper width position while the paper is fed into the printer. Squeeze the blue lever to move the guide, and position the guide so that it touches the paper edge.

2 Release lever

Use this lever when removing a jammed paper. By moving the lever up, the paper pressure rollers are unlocked and you can remove paper jammed inside the front cover.

3 Edge guide

Supports paper while the paper is fed into the printer. When loading paper, load the paper along this guide.

4 Paper guide unit

Move this unit when cleaning the paper feed roller. If you pull the blue lever, the entire unit moves, and you can check the paper feed roller.

Spindle and Flange

Used to supply the paper from the inside.

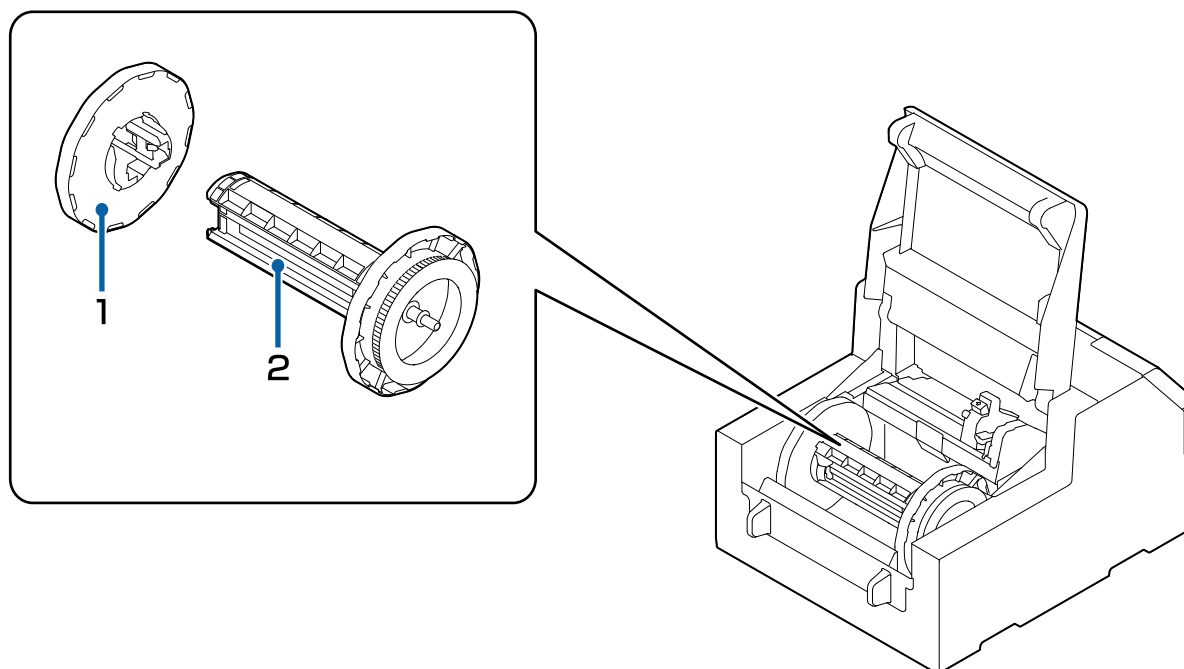

1	Flange
Attach this to the spindle to fix the roll paper loaded on the spindle. Squeeze the blue lever to attach or remove to/from the spindle.	
2	Spindle
Load roll paper on this spindle.	

Operation Panel

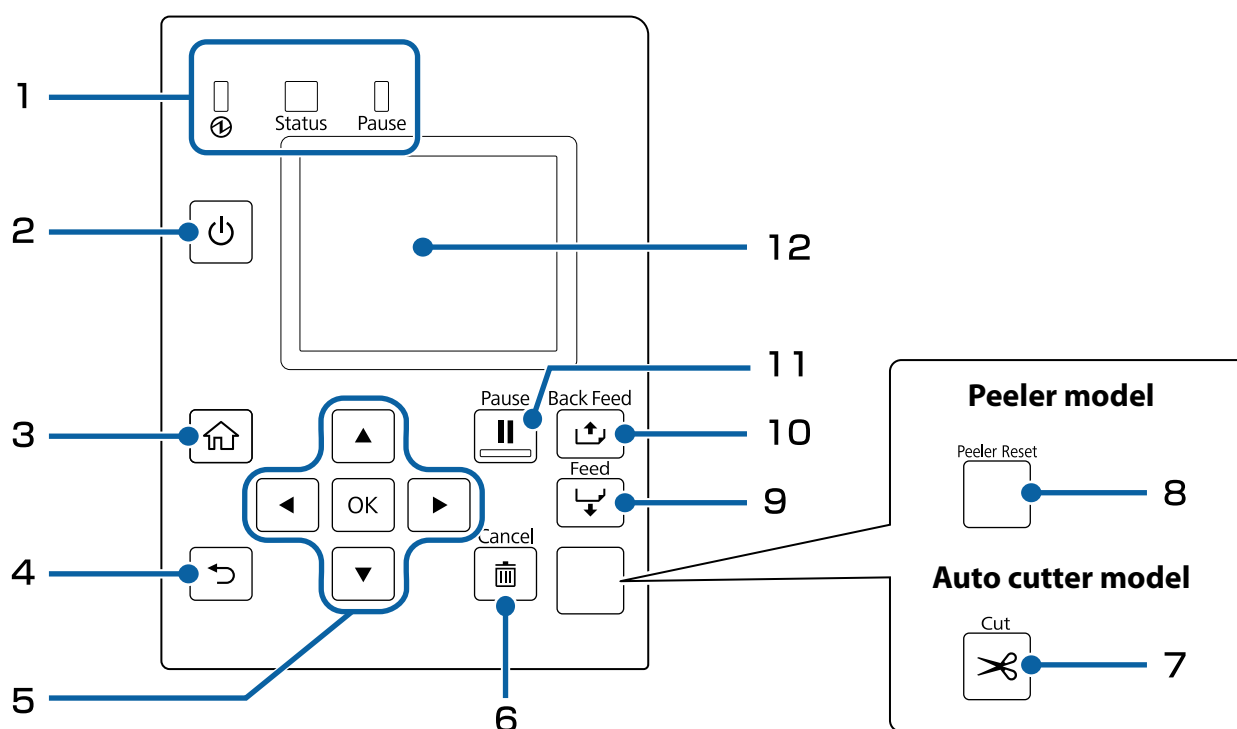

1 LED

The status of the printer can be checked from the flashing of the LEDs. This allows you to know the cause of an error and how to resolve the problem. For details, refer to the CW-C6000 Series/CW-C6500 Series Technical Reference Guide.

- (power) LED
Stays on while the printer is on. Flashes during printing or charging ink.
- Status LED
Stays on or flashes while an error or problem is occurring.
- Pause LED
Stays on or flashes while the printer is paused.

2 (power) button

Turns on/off the printer.

3 (home) button

Displays the Home screen.

4 (back) button

Use to return to the previous screen.



5	▲◀▼▶ (select) button, OK button
Use the arrow keys to select a menu item, and then press the OK button to activate the selected menu or setting.	
6	Cancel button
Use this to cancel printing. To cancel printing, press the [Cancel] button while the printer is paused, and select either the [Next label format] or the [All label formats] on the "Cancel Selection" screen.	
7	Cut button (Auto cutter model only)
Use to cut paper. The paper cannot be cut twice at the same position.	
8	Peeler Reset button (Peeler model only)
Press this button if printing of the next data does not start even after removing printed labels. For details, refer to " Printing is Impossible or Becomes Suddenly Impossible " on page 73.	
9	Feed button
Press this briefly to feed paper by one page. Hold down to feed paper continuously.	
10	Back Feed button
Use to replace paper. Hold down this button to feed the paper backward until you can pull the paper out of the printer.	
11	Pause button
<p>If this button is pressed during printing:</p> <ul style="list-style-type: none"> Printing is paused after printing of the current page is finished, and the Pause LED comes on. If the button is pressed again, printing resumes and the Pause LED goes off. <p>If this button is pressed while the printer is in the standby state:</p> <ul style="list-style-type: none"> The printer pauses and the Pause LED comes on. If the button is pressed again, the printer returns to the standby state and the Pause LED goes off. <p>If this button is pressed while printing is paused due to an error:</p> <ul style="list-style-type: none"> The printer is released from pause mode and the Pause LED goes off. 	
12	Screen
Status of the printer, menus, and error messages are displayed.	

Basic Operation



This chapter describes the basic operating procedures of the printer.

Turning On/Off

Turning the Power On

Hold down the  (power) button until the  (power) LED lights up.

Turning the Power Off

Hold down the  (power) button until a power-off confirmation message is displayed. Then select [Yes] on the confirmation screen. The  (power) LED goes out and the printer is turned off.

Opening the Paper Cover

This section describes how to open the paper cover.



CAUTION

Do not use the printer with the paper cover removed. Doing so will cause the printer to malfunction.

Opening the Cover using the Lever in the Front

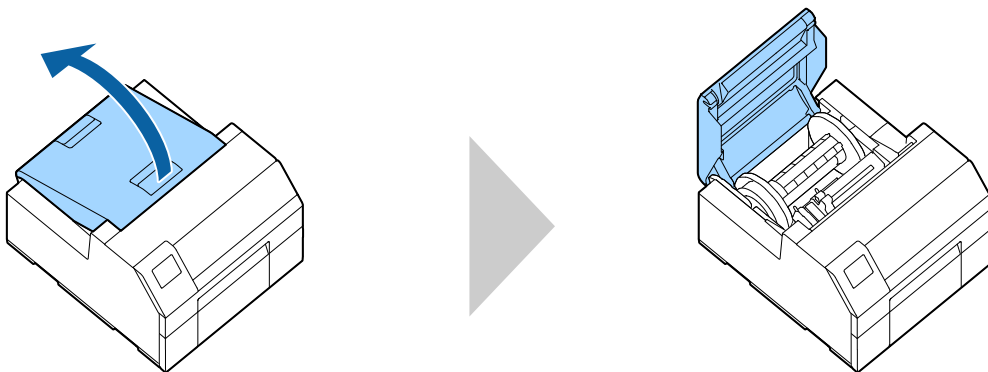

Open the paper cover as shown above for the following purposes.

- To load roll paper inside the printer, or to remove it.
- To replace the maintenance box.
- To clean inside the printer.
- To remove paper jammed inside the printer.

Opening the Cover using the Lever in the Back

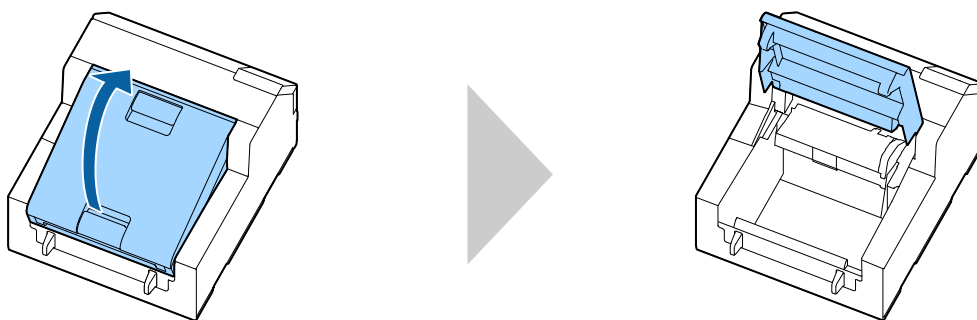

Open the paper cover as shown above for the following purposes.

- To set paper so that it is supplied from outside the printer, or to remove the paper.

Checking the Printer Status

The status of the printer can be checked from the lighting/flashing of the LEDs, and from the printer screen. Also, by printing the status sheet, you can check the printer settings and condition of the nozzles.

([☞ "Printing Status Sheet" on page 30](#))

Checking the Paper Information

Information of currently loaded paper; paper type, paper source setting, and remaining amount of roll paper, is displayed on the home screen.

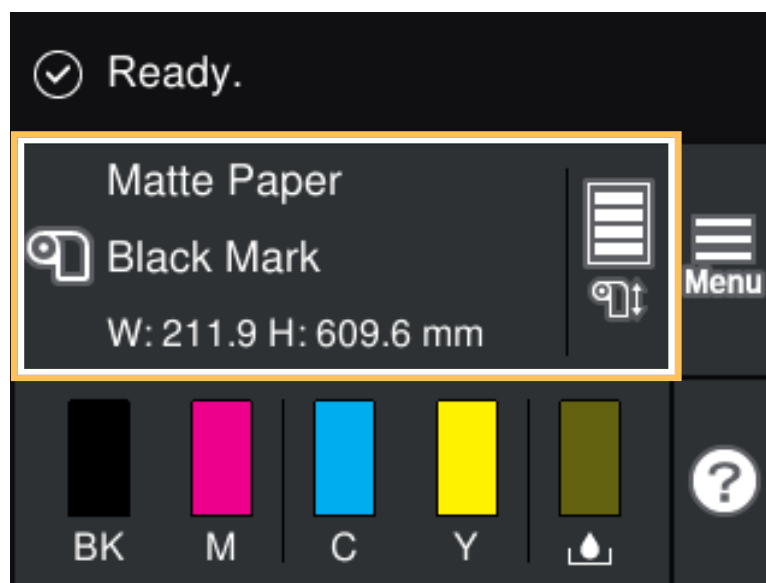

NOTE

Select this area to directly access the [Paper Settings] menus.

You can also make the paper settings using the printer driver. ([☞ "Printer Driver Settings" on page 35](#))

If the settings differ between the operation panel and the printer driver, the settings of the printer driver are applied.

Checking the Status of Consumables

The status of the ink cartridges and the maintenance box can be checked on the screen.

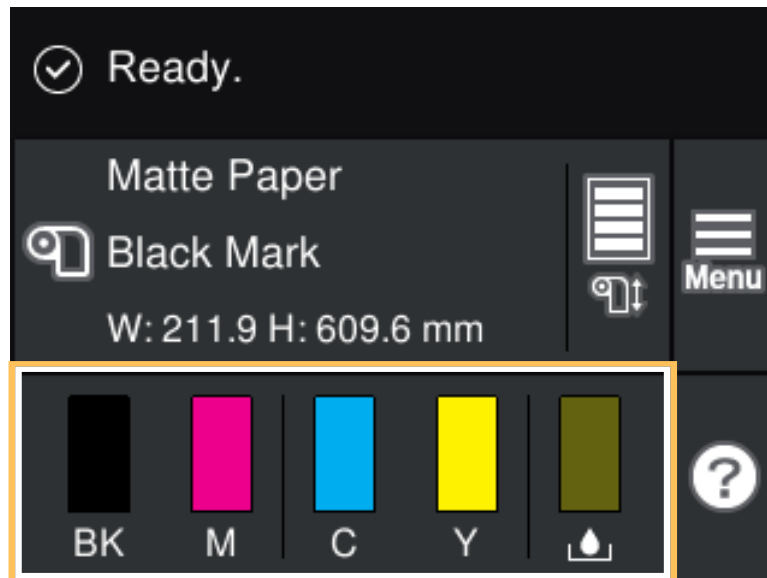

Printing Nozzle Check Patterns

By printing the nozzle check patterns, you can check the print head nozzles for clogging. To print the check patterns, select the menu as described below.

Using the Operation Panel

[Menu] - [Maintenance] - [Print Head Nozzle Check]

Using the Printer Driver

Click [Nozzle Check] on the [Printer Utilities] window.

Using the WebConfig

Select [Print Nozzle Check Pattern] on the [Maintenance] window, and then click [Start].

Printing Status Sheet

By printing the status sheet, you can check the firmware version and printer settings such as the print mode and media detection settings. The following types of status sheets can be printed from the operation panel.

[Menu] - [Printer Status/Print] - [Print Status Sheet]

Status sheet print sample	Status sheet (network settings) print sample
<pre> <Printer Status Sheet> Sheet Output Time YYYY.MM.DD hh:mm <Basic Information> Model XX-XXXX BK Serial Number XXXXXXXXX Main Firmware Version XXXXXXXX MAC Address XX:XX:XX:XX:XX IP Address Setting Auto/Manual IP Address XXX.XXX.XXX.XXX Subnet Mask XXX.XXX.XXX.XXX Gateway Address XXX.XXX.XXX.XXX Head ID XXXXXXXXXXXXXXXXXXXXXXXXXXXXXXXX -- ^^^^ ^^^^ 03 xxxx yyyy/mm/dd hh:mm 04 xxxx yyyy/mm/dd hh:mm 05 xxxx yyyy/mm/dd hh:mm 06 xxxx yyyy/mm/dd hh:mm 07 xxxx yyyy/mm/dd hh:mm 08 xxxx yyyy/mm/dd hh:mm 09 xxxx yyyy/mm/dd hh:mm 10 xxxx yyyy/mm/dd hh:mm </pre>	<pre> HHH NetWork Status Sheet HHH <General Information> MAC Address XX:XX:XX:XX:XX:XX Firmware XXXXXXXXX Network Status AUTO(Disconnected) <TCP/IP IPv4> Obtain IP Address Manual IP Address XXX.XXX.XXX.XXX Subnet Mask XXX.XXX.XXX.XXX Default Gateway XXX.XXX.XXX.XXX HHHHHHHHHHHH 1/1 HHHHHHHHHHHH </pre>

 NOTE	<p>You can also print a list of the fonts and bar codes that are already registered in the printer, or the newly registered images and templates.</p>
--	---

Checking Network Connection and Settings

You can check the network connection status and settings by printing a network connection check report. For more details, see the CW-C6000 Series/CW-C6500 Series Technical Reference Guide.

Replacing the Ink Cartridges

This section describes how to replace the ink cartridges.

 CAUTION	<ul style="list-style-type: none"> • Carefully read the cautions on handling before installing the ink cartridges. (↶ "Cautions on Ink Cartridges" on page 13) • When replacing the black ink cartridge, make sure to replace with a cartridge of the same type of black ink. The printer does not work if you install a cartridge of different type of black ink.
---	--

Checking Amount of Ink Remaining

You can check ink level of each color ink cartridge on the home or an error message screen of the operation panel.

Message	Description
You need to replace Ink Cartridge(s).	Replace the ink cartridge. To maintain the quality of the print head, the printer stops printing before ink cartridges are completely expended.

How to Replace the Ink Cartridges

The procedure below is for replacing the BK cartridge. Follow the same procedure for replacing the other color cartridges.

IMPORTANT

When replacing the black ink cartridge, make sure to replace with a cartridge of the same type of black ink. The printer does not work if you install a cartridge of different type of black ink.

1 Open the left ink cartridge cover.

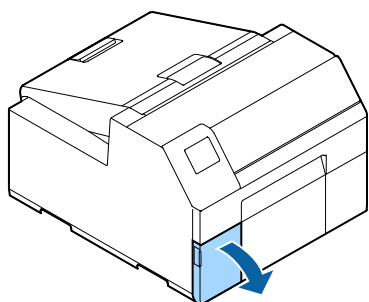

NOTE

For replacing cyan or yellow cartridge, open the right ink cartridge cover.

2 Press the lever down to remove the used ink cartridge.

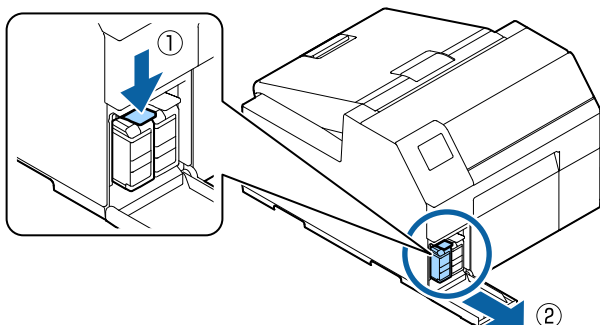

3 Open the bag and take out the new ink cartridge.

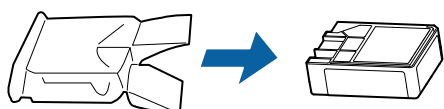

4 Shake the ink cartridge.

As shown in the figure below, shake the cartridge horizontally. Move the cartridge by about 5 cm to both directions, and repeat it about 15 times for about 5 seconds.

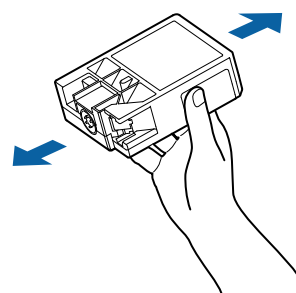

5 Install the ink cartridge in the slot.

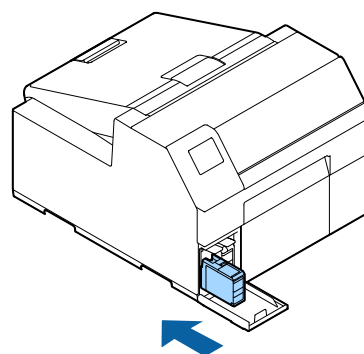

6 Close the ink cartridge cover.

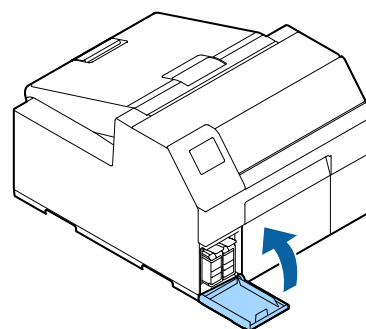

Replacing the Maintenance Box

This section describes how to replace the maintenance box.



Carefully read the cautions on handling before setting the maintenance box. ( ["Cautions on the Maintenance Box" on page 15](#))

Checking the Amount of Empty Space in the Maintenance Box

You can check the remaining capacity of the maintenance box on the home or an error message screen of the operation panel.

Message	Description
The Maintenance Box is at the end of its service life. You need to replace it.	Replace the maintenance box with a new one.

How to Replace the Maintenance Box

- 1** Open the paper cover.

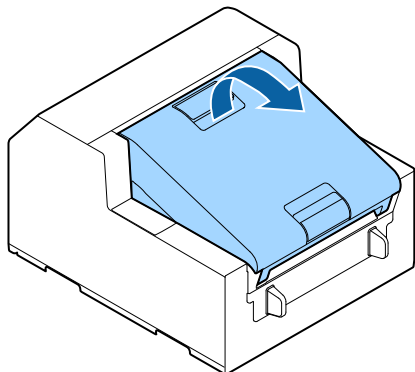

- 2** Open the maintenance box cover.

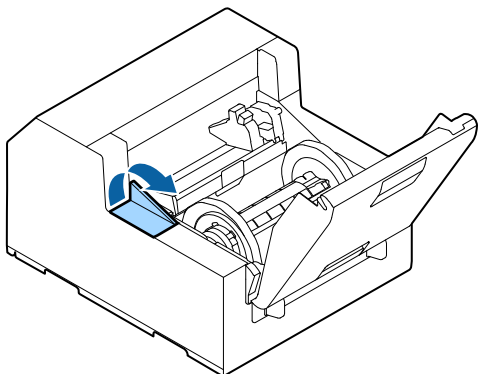

- 3** Take out the maintenance box.
When disposing of the used maintenance box, put it in a plastic bag that came with the new maintenance box.
(☞ "Disposal of Maintenance Box" on page 86)

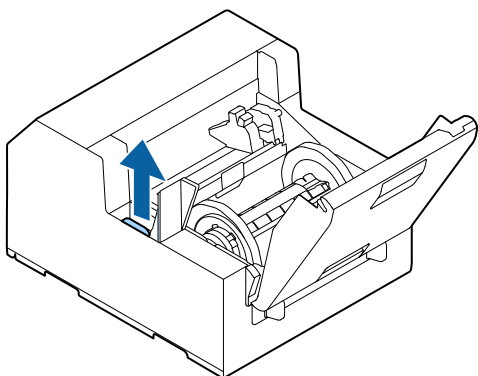

- 4** Take out a new maintenance box from the bag.

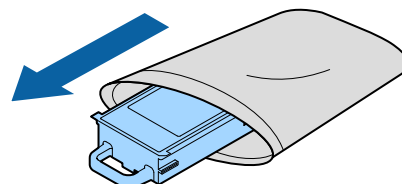

- 5** Install the new maintenance box.

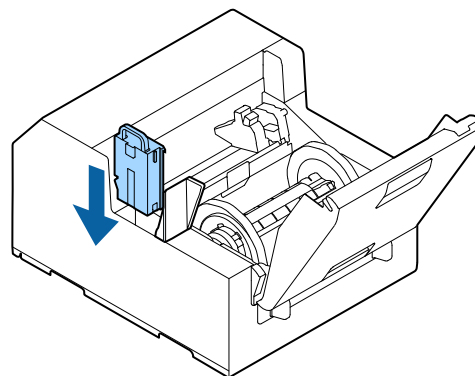

- 6** Close the maintenance box cover.

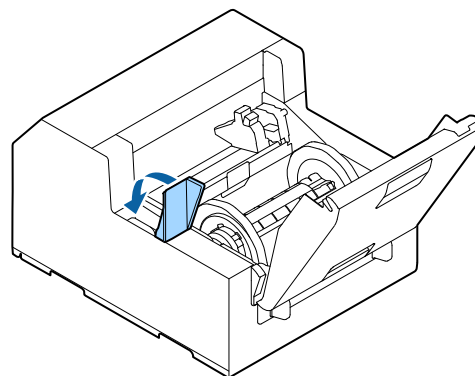

Printer Driver Settings

Set the basic items required for printing such as the size and form of media.

The printer driver is equipped with a help function. Right-click an item and then click Help to display an explanation on the item.

You can also learn how to configure the printer driver with videos. Access the videos from the following URL.

<https://support.epson.net/p_doc/790/>

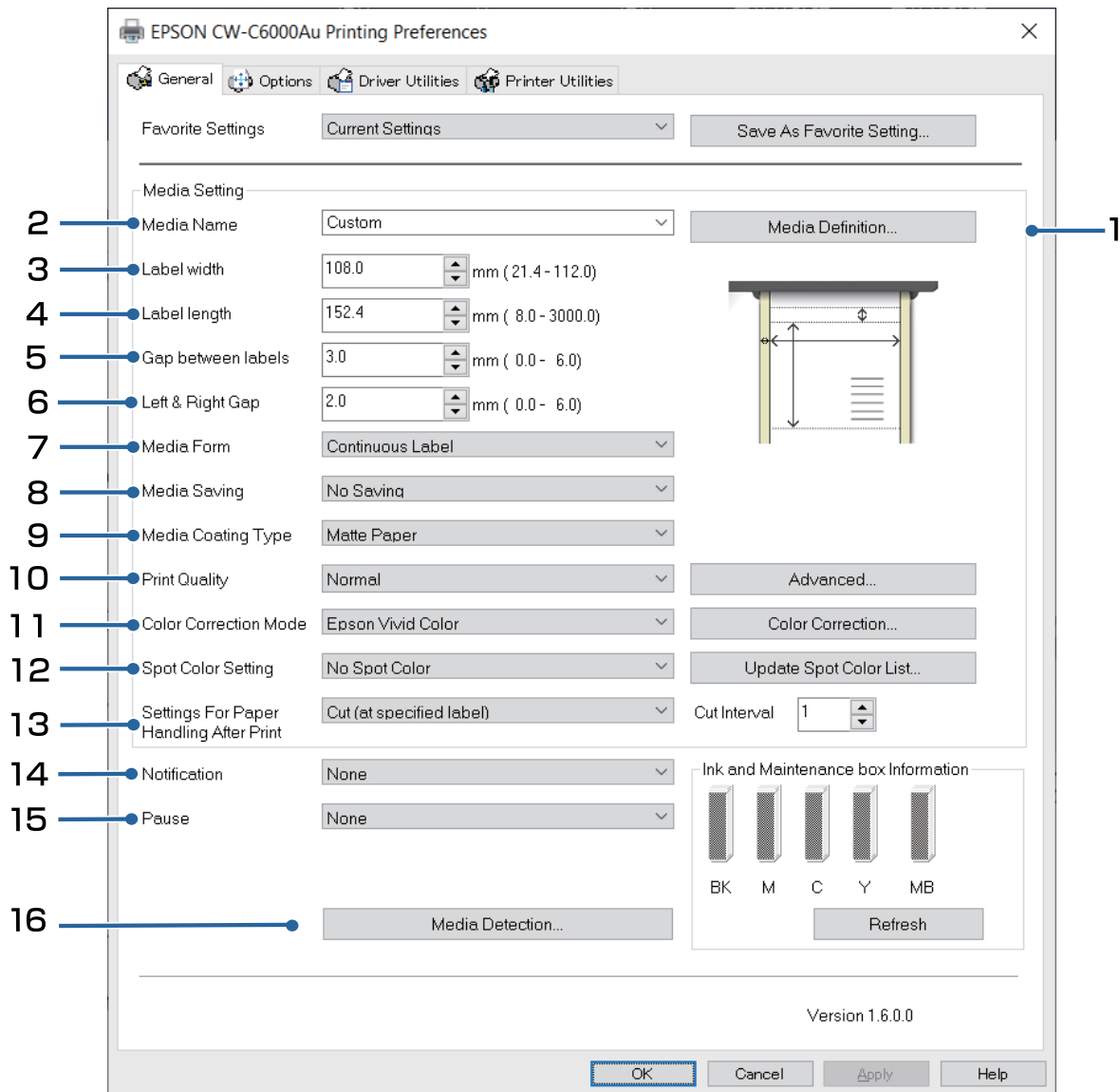

NOTE

If the settings on the printer (settable using the operation panel, CW-C6000 Series/CW-C6500 Series PrinterSettings, or WebConfig) differ from the printer driver settings, printing is performed by applying the printer driver settings.

1 Media Definition

The size, form, type, and other settings of frequently used paper can be registered as a media definition. The set media definition can be selected from the Media Name pull-down menu. This is convenient because you will not need to set the paper settings of the driver when printing from an application if you register a media definition in advance.

If you wish to set the paper size and other settings every time without registering a media definition, select [Custom] from the [Media Name] pull-down menu on the [General] tab. The various settings on the [General] tab will become available so that you can set the paper size and other settings.

2 Media Name

- 108 x 152.4 mm - Die-cut Label* (Initial setting)
- Custom

*: This setting is suitable for printing the roll paper included with the product.

3 Label Width

For CW-C6000 Series

Can be specified from 21.4 to 112.0 mm

Initial setting: 108.0 mm

For CW-C6500 Series

Can be specified from 21.4 to 215.9 mm

Initial setting: 108.0 mm

4 Label Length

For the auto cutter model

Can be specified from 8 to 609.6 mm

Initial setting: 152.4 mm



NOTE

- If the interval for cutting the paper is less than 15.0 mm, auto cutting is not possible because a paper jam may occur. If you want to use auto cutting for labels less than 15.0 mm, set the interval for cutting the paper to 15.0 mm or more in the settings for paper handling after print. ([🔗 "13 Settings For Paper Handling After Print" on page 39](#))

For the peeler model

Can be specified from 12.7 to 609.6 mm

Initial setting: 152.4 mm

5 Gap between Labels

When [Media Form] is other than [Continuous Label]

2 to 6 mm

Initial setting: 3 mm

When [Media Form] is [Continuous Label]

0 to 6 mm

Initial setting: 3 mm

6 Left & Right gap

Auto cutter model

The waste parts can be set within a range of 2 to 6 mm. (They should normally be set to 2 mm.)

Peeler model

The waste parts can be set to 2 mm only.

**NOTE**

If they are set larger than 2 mm, problems such as paper jams might occur.

7 Media Form

- Die-cut Label (Gap) (Initial setting)
- Die-cut Label (BlackMark)
- Continuous Label (BlackMark)
- Continuous Label
- Continuous paper (BlackMark)
- Continuous paper

8 Media Saving

Enabled only when [Continuous Label] is selected as the [Media Form].

- Eliminate Lower Margin
- Eliminate Lower and Upper Margin
- No Saving (Initial setting)

9 Media Coating Type

- Plain Paper

- Matte Paper (Initial setting)
- Synthetic
- Texture Paper
- Glossy Paper
- Glossy Film
- High Glossy Paper

10 Print Quality

When [Media Coating Type] is [Plain Paper]

- Max Speed
- Speed (Initial setting)
- Normal
- Quality

When [Media Coating Type] is [Matte Paper], [Synthetic], or [Texture Paper]

- Max Speed
- Speed
- Normal (Initial setting)
- Quality

When [Media Coating Type] is [Glossy Paper], [Glossy Film], or [High Glossy Paper]

- Normal
- Quality (Initial setting)
- Max Quality

**NOTE**

If you change the [Media Coating Type], the [Print Quality] will automatically be set to the initial setting suitable for the selected paper type.

11 Color Correction Method

- Epson Vivid Color (Initial setting)
- ICM
- None

12 Spot Color Settings

No Spot Color (Initial setting)

13 Settings For Paper Handling After Print

For the auto cutter model

- Cut (after printing last label)
- Cut (at specified label)
- Cut (after last page of collate page)
- Do not cut (stop at cut position) (Initial setting)
- Do not cut (stop at peel position)
- Do not cut (stop at the print end position)



NOTE

Cautions for when [Label Length] is set to a value less than 15.0 mm

- Auto cutting is not possible because a paper jam may occur.
- You can still select all the following three [Cut] options in [Settings For Paper Handling After Print].
 - Cut (after printing last label)
 - Cut (at specified label)
 - Cut (after last page of collate page)
- When [Settings For Paper Handling After Print] - [Cut (at specified label)] - [Cut Interval] is set to "1", the driver automatically changes [Cut Interval] to "2" to reach or exceed the minimum label length that can be cut (15.0 mm).
Also, to ensure that the label length does not become less than the minimum label length that can be cut (15.0 mm), "1" can no longer be set for [Cut Interval].

For the peeler model

- Manual apply (Initial setting)
- Auto apply
- Rewind

14 Notification

For the auto cutter model

- None (Initial setting)
- Beep at Cut
- Beep at Job End
- Last Page at Collate End

For the peeler model

- None (Initial setting)
- Beep at Job End
- Last Page at Collate End

15 Pause

For the auto cutter model

- None (Initial setting)
- Pause at Cut
- Pause at Job End
- Last Page at Collate End

For the peeler model

- None (Initial setting)
- Pause at Job End
- Last Page at Collate End

16 Media Detection...

Media source

- Internal roll (Initial setting)
- External feed

Media Detection

- Gap detection (Initial setting)
- Black mark detection
- No detection

Loading and Replacing Paper

This section describes how to load and replace paper. As shown below, the procedure of replacing paper differs depending on the size and whether paper has been/is going to be supplied from inside or outside. Videos that show the procedure are also available.

Click the URL below to view the videos.

<https://support.epson.net/p_doc/790/>

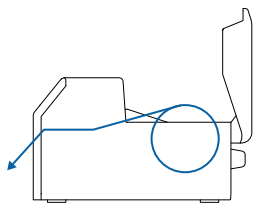
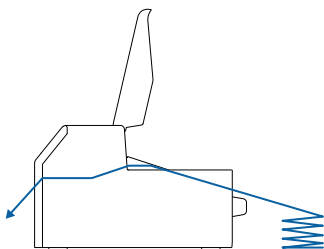
<p>Supply from Inside (Internal) Paper is supplied from inside the printer. Set roll paper attached to the spindle into the printer.</p> 	<p>Supply from Outside (Rear Feed) Fanfold paper can be supplied from outside the printer by placing it behind the printer. (Auto cutter model only)</p> 
---	---

 <p>IMPORTANT</p>	<ul style="list-style-type: none"> • To supply roll paper from outside the printer, prepare an external paper feeder and paper rewriter by yourself. For more details, see the CW-C6000 Series/CW-C6500 Series Technical Reference Guide. • With the peeler model, you can not supply fanfold paper from outside the printer. • When replacing paper with a different shape, form, or type of paper, change the paper settings either from the operation panel or on the printer driver before loading the paper. (☞ "Checking the Paper Information" on page 28, "Printer Driver Settings" on page 35)
--	--

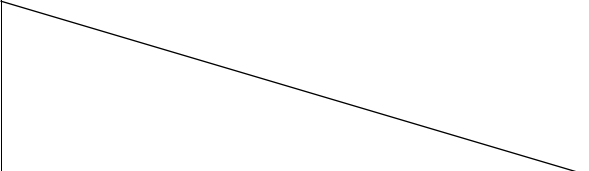
Models	Supply from Inside (Internal)	Supply from Outside (Rear Feed)
Auto Cutter Model	<ul style="list-style-type: none"> • Paper loading: page 42 • Paper removal: page 52 • Paper ejection at paper end: page 54 	<ul style="list-style-type: none"> • Paper loading: page 45 • Paper removal: page 52 • Paper ejection at paper end: page 54
Peeler Model	<ul style="list-style-type: none"> • Paper loading: page 48 • Paper removal: page 53 • Paper ejection at paper end: page 55 	

How to Load Paper (Auto Cutter Model - Supply from Inside)

CAUTION

After turning on the printer, do not open the paper cover until the home screen is displayed. Doing so may cause paper to be set improperly.

- 1 Turn on the printer, and then check that [Internal] is selected as the [Media Source] setting on the operation panel.**
(👉 "Checking the Paper Information" on page 28)

- 2 Open the paper cover.**

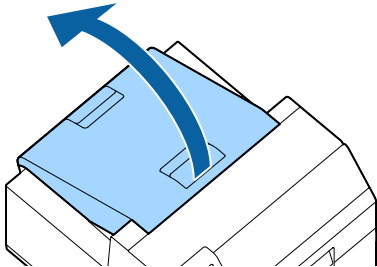

- 3 Remove the spindle from the printer.**
As shown in the figure, hold the spindle and flange with both hands, and remove them.

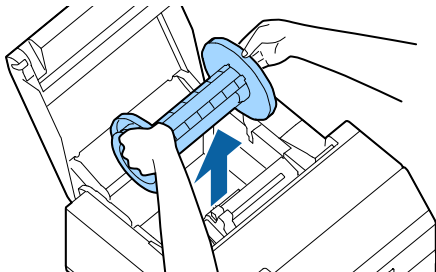

- 4 Load the roll paper on the spindle and fix it with the flange.**

- To move the flange, squeeze the two levers.
- When loading the roll paper on the spindle, take note of the winding direction. The correct winding direction is marked on the spindle.
- Fix the flange and roll paper so that there is no gap in between.

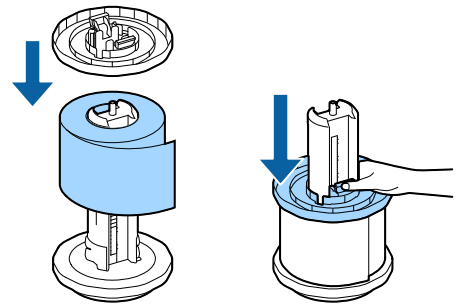

- 5 Hold the spindle with both hands, and set it in the printer.**

Install the spindle so that both ends of the spindle fit into the holders inside the printer.

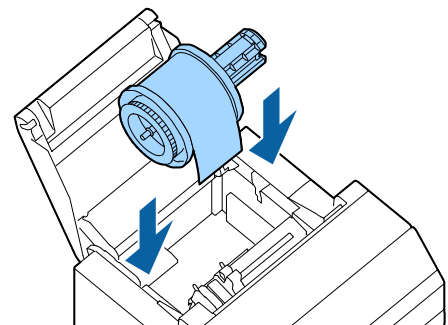

- 6 Slide the movable edge guide to the right side.**
Squeeze the blue lever to move the edge guide.

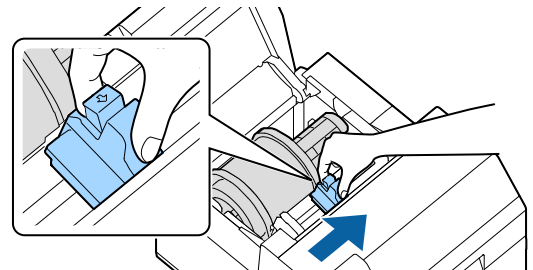

7 Pull the paper along the left edge guide.

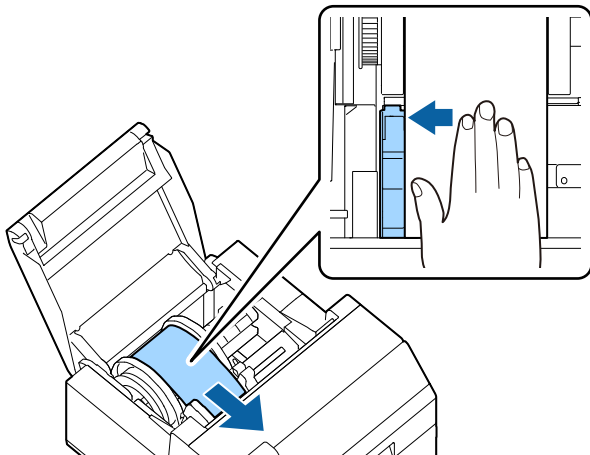

8 Place your hand on the paper to flatten it, and slide the movable edge guide against the paper.

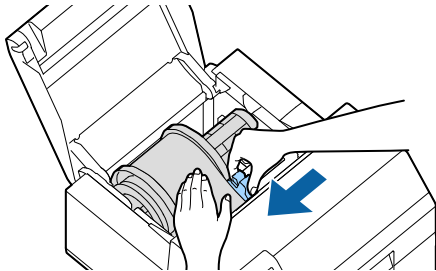

CAUTION

If the movable edge guide is not properly slid against the paper, print position may become incorrect or a paper jam may occur. Make sure to follow the guidelines below.

- There should be no gap between the guide and the paper edge.

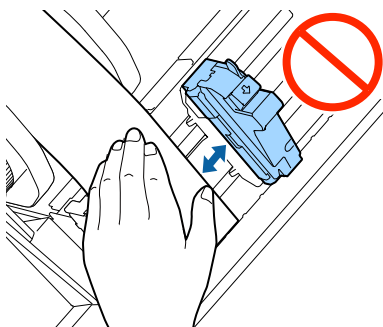

- Do not slide the guide against the paper too tightly.

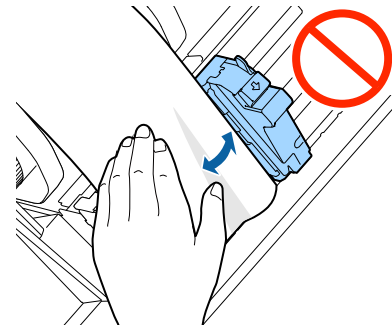

9 Insert the paper into the paper feed slot until paper feeding starts automatically.

Do not load backing paper that has no labels on it. The paper may not be detected and not be fed automatically.

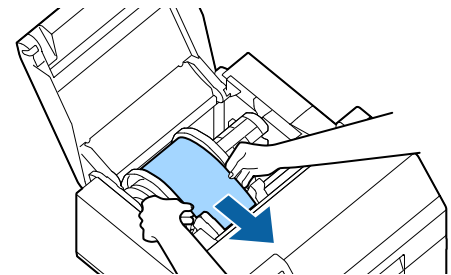

10 Rotate the spindle to remove looseness in the paper.

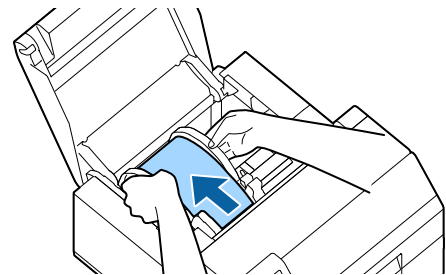

11 Close the paper cover.

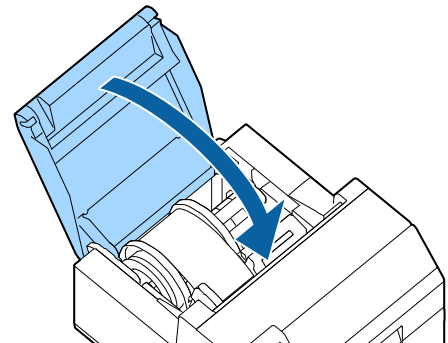

12 Press the Pause button.

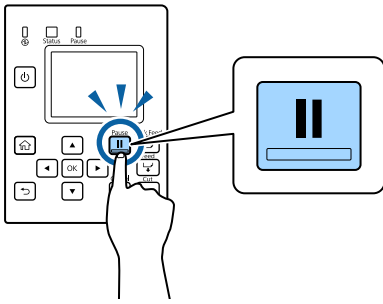

Loading paper (auto cutter model - supply from inside) is now completed.

How to Load Paper (Auto Cutter Model - Supply from Outside)

CAUTION

After turning on the printer, do not open the paper cover until the home screen is displayed. Doing so may cause paper to be set improperly.

- 1 Turn on the printer, and then check that [Rear Feed] is selected as the [Media Source] setting on the operation panel.**
(👉 "Checking the Paper Information" on page 28)

- 2 Open the paper cover.**

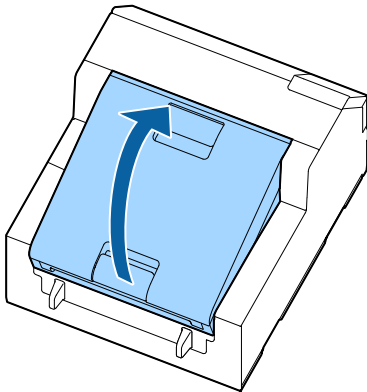

- 3 Remove the spindle, if present.**
As shown in the figure, hold the spindle and flange with both hands, and remove them.

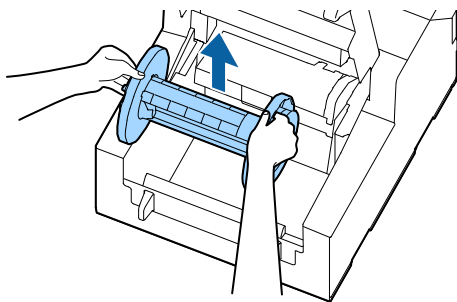

- 4 Place the fanfold paper behind the printer.**

- Place the fanfold paper at least 100 mm away from the printer.
- Make sure the paper is vertical in relation to the paper feed slot.

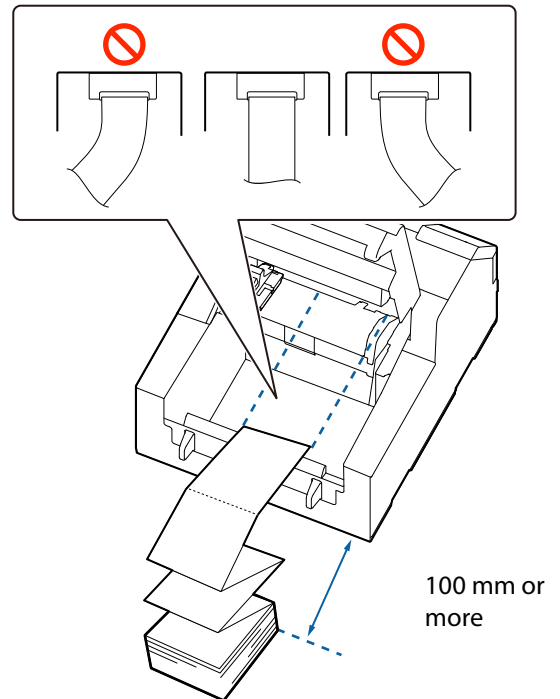

CAUTION

Make sure not to let the fanfold paper to curl near the printer. Doing so will deform the paper resulting in a paper jam or a print quality problem.

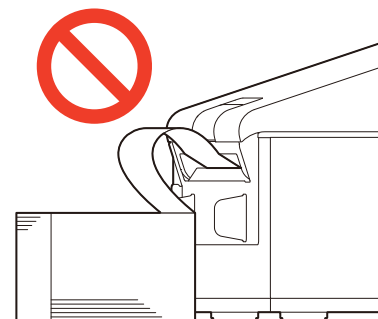

- 5 Slide the movable edge guide to the left side.**
Squeeze the blue lever to move the edge guide.

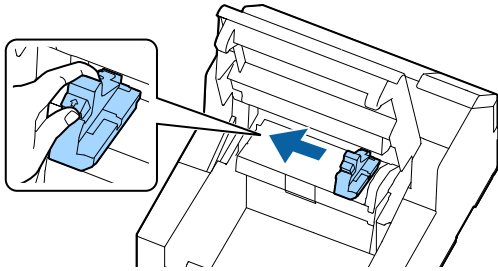

- 6 Pull the paper along the right edge guide.**

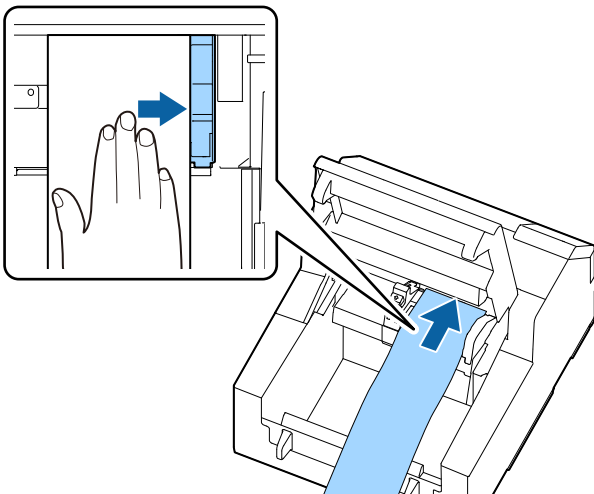

- 7 Place your hand on the paper to flatten it, and slide the movable edge guide against the paper.**

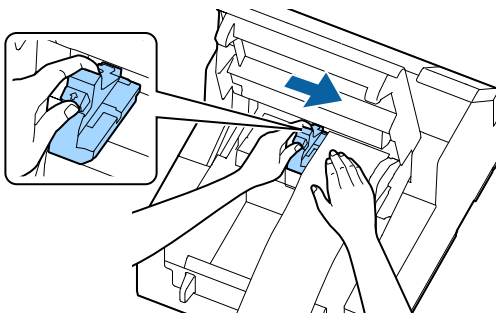

CAUTION

If the movable edge guide is not properly slid against the paper, print position may become incorrect or a paper jam may occur. Make sure to follow the guidelines below.

- There should be no gap between the guide and the paper edge.

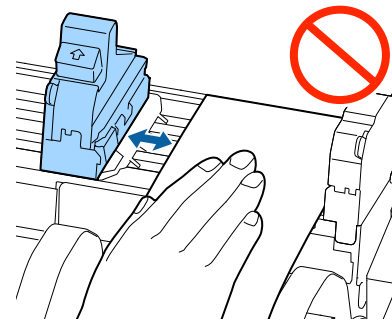

- Do not slide the guide against the paper too tightly.

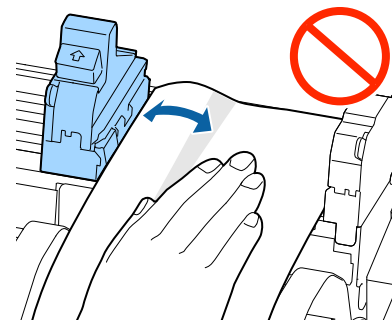

- 8 Load the paper to the paper feed slot until paper feeding starts automatically.**

Do not load backing paper that has no labels on it. The paper may not be detected and not be fed automatically.

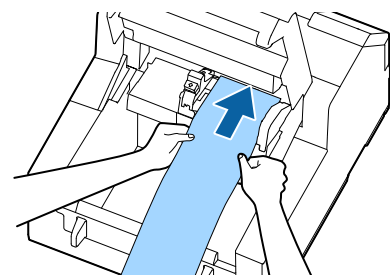

- 9 Close the paper cover.**

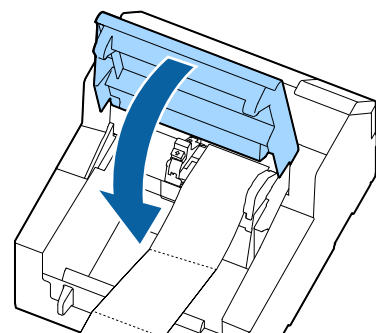

10 Press the Pause button.

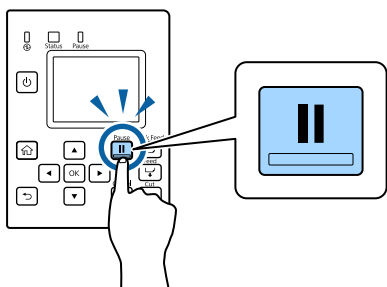

Loading paper (auto cutter model - supply from outside) is now completed.

How to Load Paper (Peeler Model - Supply from Inside)

CAUTION

After turning on the printer, do not open the paper cover until the home screen is displayed. Doing so may cause paper to be set improperly.

- 1 Turn on the printer, and then check that [Internal] is selected as the [Media Source] setting on the operation panel.**
(☞ "Checking the Paper Information" on page 28)

- 2 Open the paper cover.**

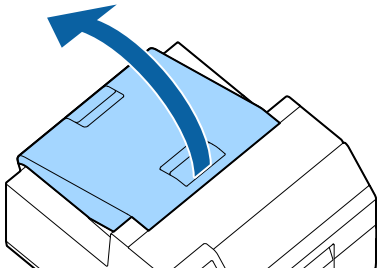

- 3 Remove the spindle from the printer.**
As shown in the figure, hold the spindle and flange with both hands, and remove them.

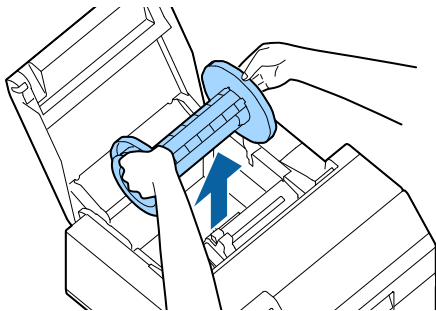

- 4 Load the roll paper on the spindle and fix it with the flange.**

- To move the flange, squeeze the two levers.
- When loading the roll paper on the spindle, take note of the winding direction. The correct winding direction is marked on the spindle.
- Fix the flange and roll paper so that there is no gap in between.

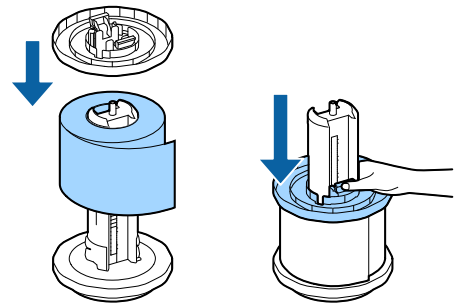

- 5 Hold the spindle with both hands, and set it in the printer.**

Install the spindle so that both ends of the spindle fit into the holders inside the printer.

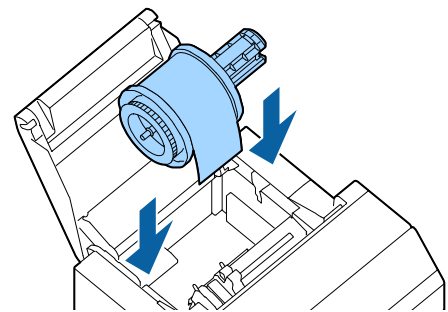

- 6 Slide the movable edge guide to the right side.**
Squeeze the blue lever to move the edge guide.

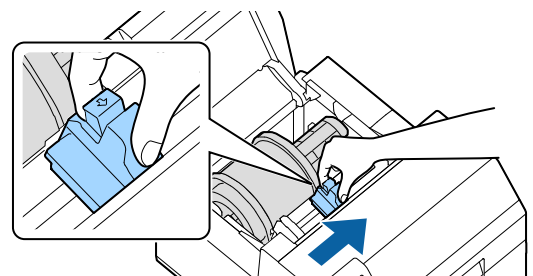

7 Pull the paper along the left edge guide.

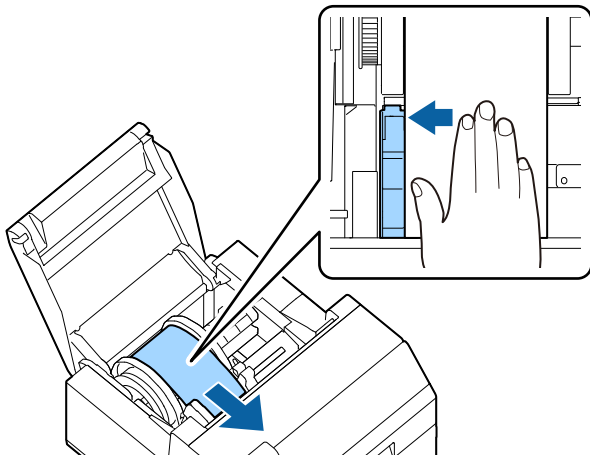

8 Place your hand on the paper to flatten it, and slide the movable edge guide against the paper.

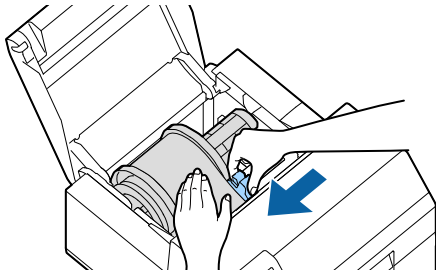

CAUTION

If the movable edge guide is not properly slid against the paper, print position may become incorrect or a paper jam may occur. Make sure to follow the guidelines below.

- There should be no gap between the guide and the paper edge.

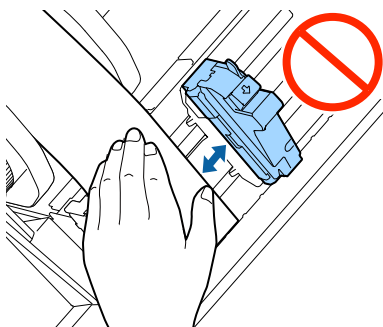

- Do not slide the guide against the paper too tightly.

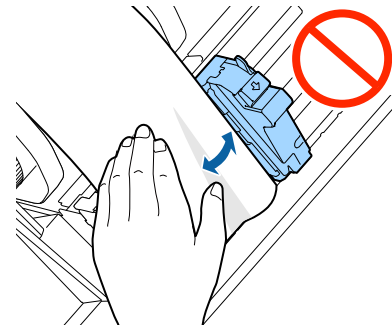

9 Insert the paper into the paper feed slot until paper feeding starts automatically.

Do not load backing paper that has no labels on it. The paper may not be detected and not be fed automatically.

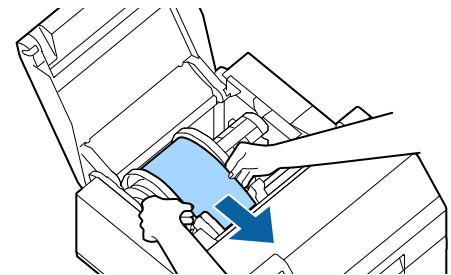

10 Rotate the spindle to remove looseness in the paper.

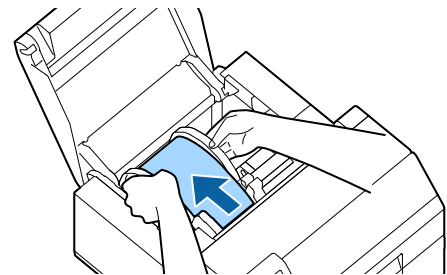

11 Close the paper cover.

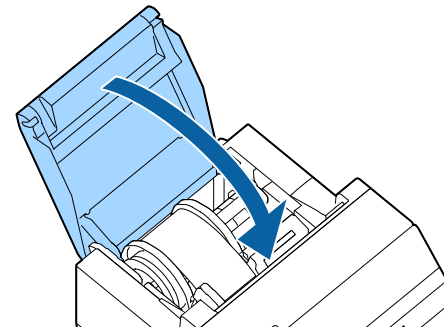

- 12** Hold down the Feed button until the leading edge of paper touches the table on which the printer is installed.

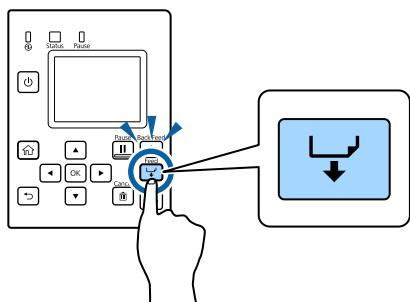

- 13** Remove labels from the ejected paper.

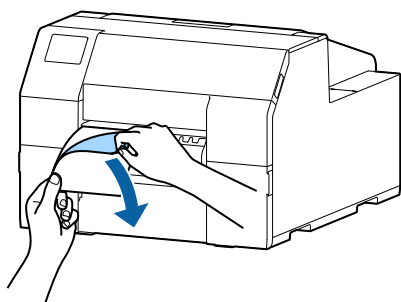

- 14** Open the peeler cover.

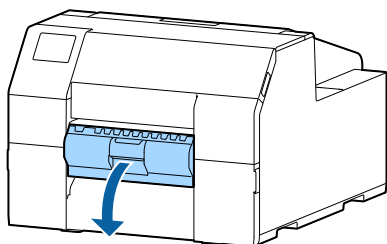

- 15** Pass the paper through the peeler slot.

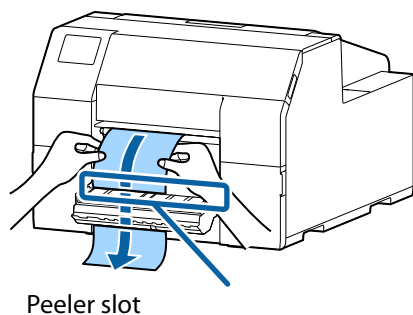

- 16** Before closing the peeler cover, load the paper along the protrusion A.

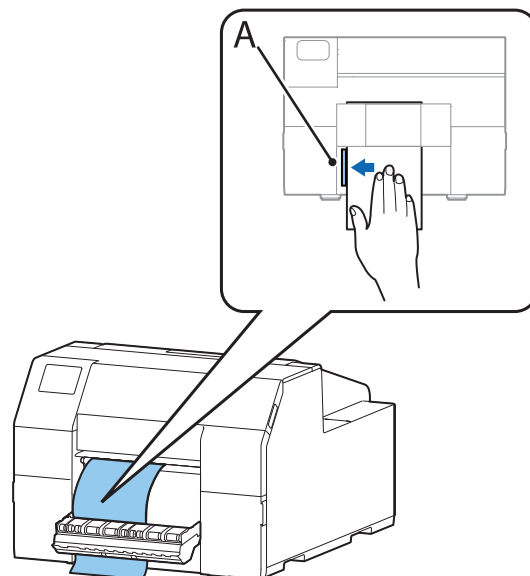

CAUTION

Make sure the paper is perfectly aligned with protrusion A.

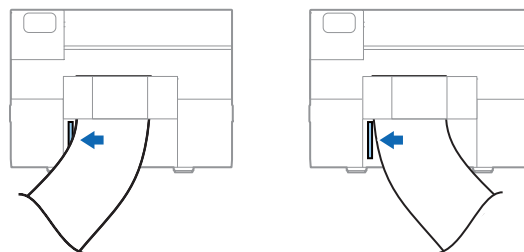

- 17** Close the peeler cover.

If the paper is loose, pull the leading edge of paper to remove the looseness and then close the peeler cover.

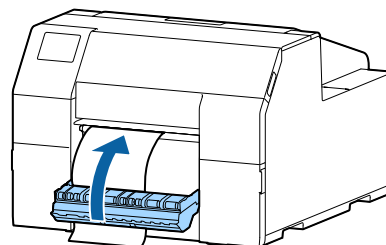

18 Press the Pause button.

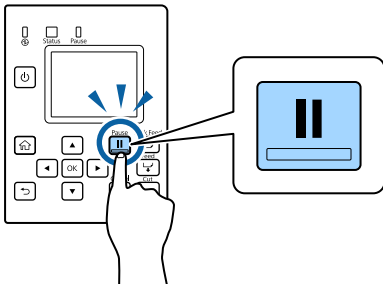

Loading paper (peeler model - supply from inside) is now completed.

How to Remove Paper (For the Auto Cutter Model)

- 1** Check that the printer has been turned on.
- 2** Press the Cut button, and cut off the ejected labels.

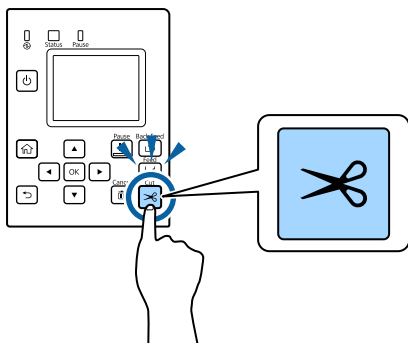

- 3** Press the Back Feed button to feed the paper backward.

The paper can now be pulled out from inside the printer.

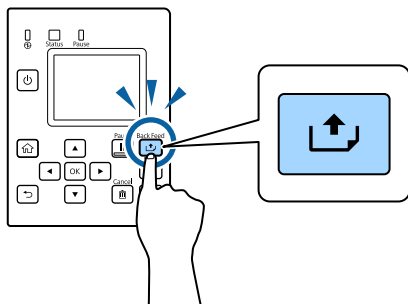

- 4** Open the paper cover.

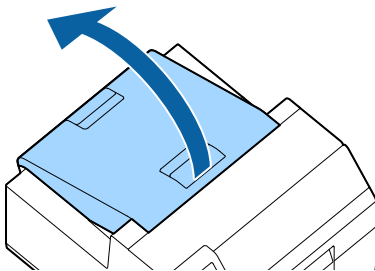

- 5** Slide the movable edge guide away from the paper, and remove the paper.

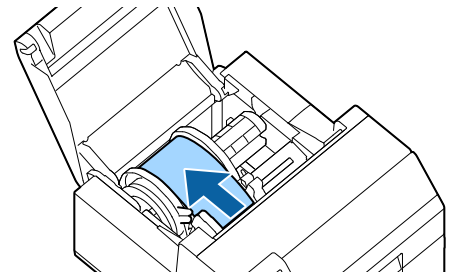

- 6** Close the paper cover.
- 7** Press the Pause button.

Removing the paper is now completed.

To load paper, see the following pages.

["How to Load Paper \(Auto Cutter Model - Supply from Inside\)"](#) on page 42

["How to Load Paper \(Auto Cutter Model - Supply from Outside\)"](#) on page 45

How to Remove Paper (For the Peeler Model)

1 Check that the printer has been turned on.

2 Open the peeler cover.

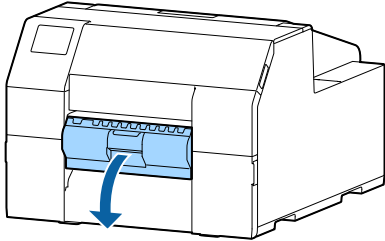

3 Cut the backing paper near the paper ejection slot.

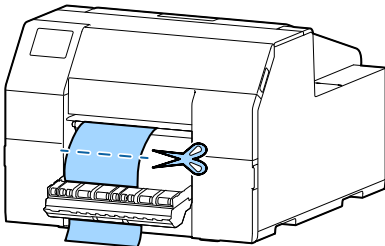

4 Press the Back Feed button to feed the paper backward.

The paper can now be pulled out from inside the printer.

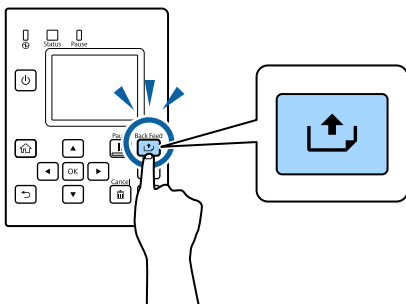

5 Open the paper cover.

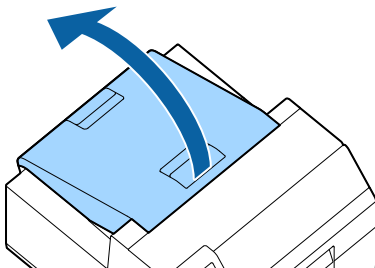

6 Slide the movable edge guide away from the paper, and remove the paper.

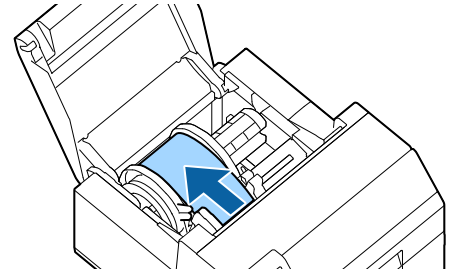

7 Close the paper cover.

8 Press the Pause button.

Removing the paper is now completed.

To load paper, see the following pages.

["How to Load Paper \(Peeler Model - Supply from Inside\)" on page 48](#)

How to Eject Paper at Paper End (For the Auto Cutter Model)

- 1 **Hold down the Feed button until the paper is completely ejected.**

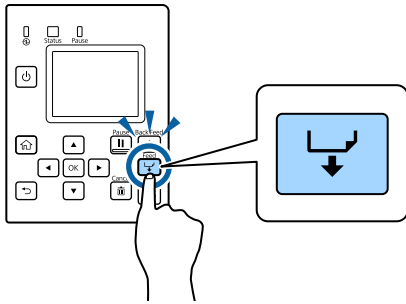

Ejecting paper at paper end is now completed.

To load paper, see the following pages.

["How to Load Paper \(Auto Cutter Model - Supply from Inside\)"](#)
on page 42

["How to Load Paper \(Auto Cutter Model - Supply from Outside\)"](#) on page 45

How to Eject Paper at Paper End (For the Peeler Model)

1 Open the peeler cover.

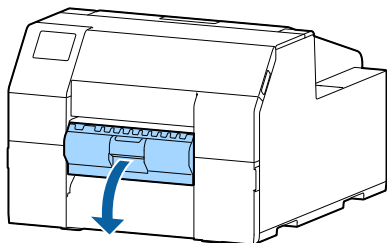

2 Remove the paper from the peeler slot.

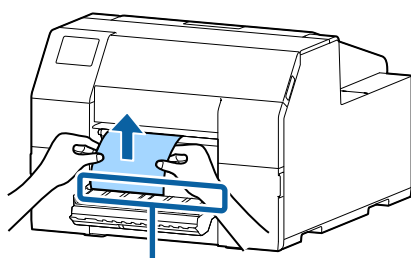

Peeler slot

3 Hold down the Feed button until the paper is completely ejected.

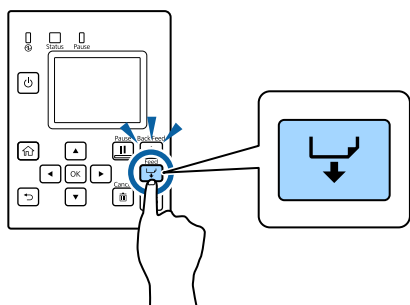

Ejecting paper at paper end is now completed.

To load paper, see the following pages.

["How to Load Paper \(Peeler Model - Supply from Inside\)" on page 48](#)

Maintenance

This chapter describes how to carry out maintenance of the printer.

Front

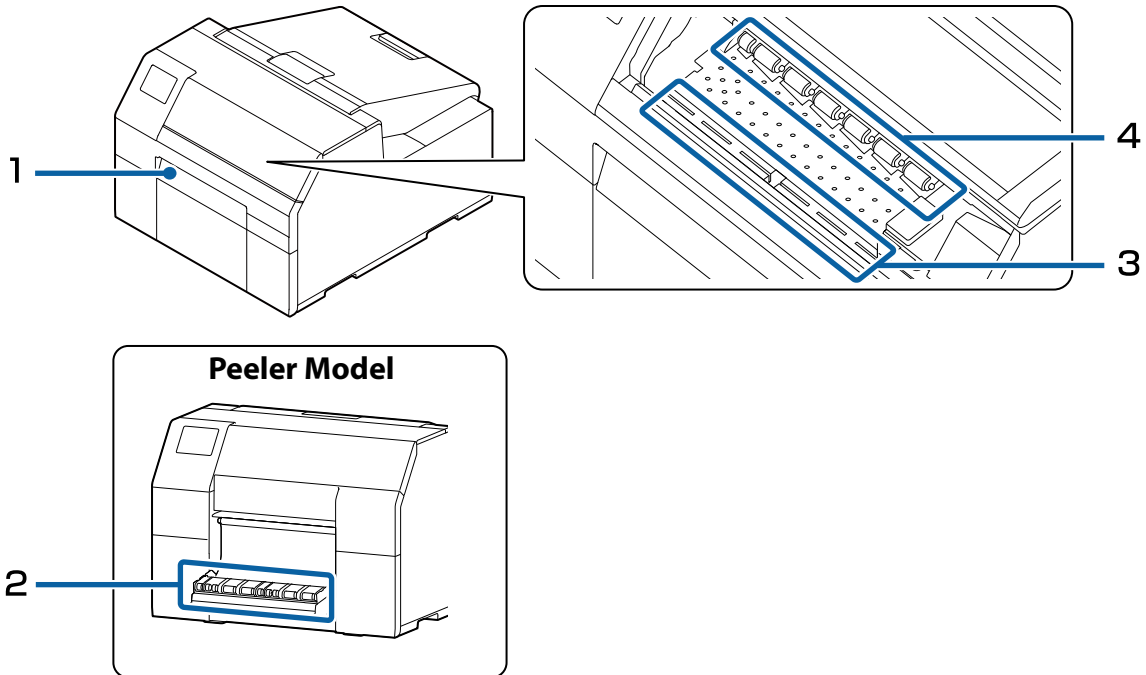

1	"Cleaning the Auto Cutter (Auto Cutter Model Only)" on page 58
2	"Cleaning the Peeler (Peeler Model Only)" on page 59
3	"Cleaning the Platen" on page 61
4	"Cleaning the Paper Pressure Roller" on page 63

Rear

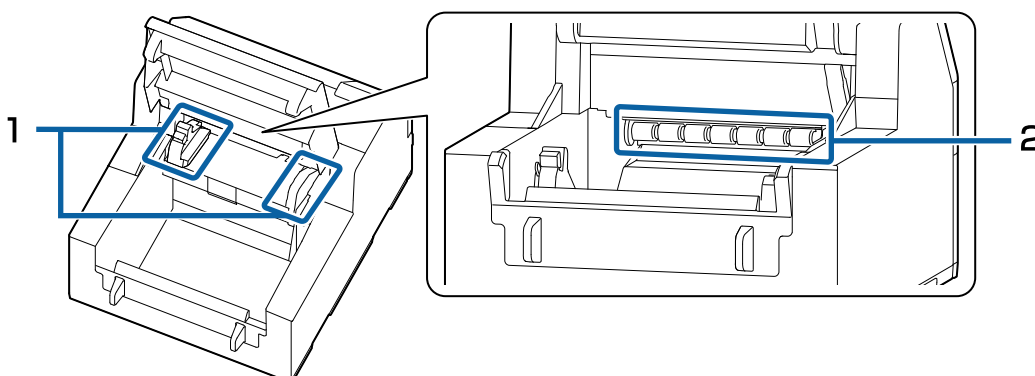

1	"Cleaning the Edge Guides" on page 60
2	"Cleaning the Paper Feed Roller" on page 62

Cleaning the Exterior

Turn off the printer, and unplug the power cable. Then wipe off any dirt with a dry cloth or non-woven fabric that has been dampened.



Do not use alcohol, benzine, thinner, trichloroethylene, or ketone based solvent to clean the exterior of the printer.

Doing so may deform or damage the plastic and rubber parts.

Cleaning the Auto Cutter (Auto Cutter Model Only)

If labels, paper dust, or adhesive has adhered to the fixed blade of the auto cutter, the blade may become dull. Clean the fixed blade following the procedure below.

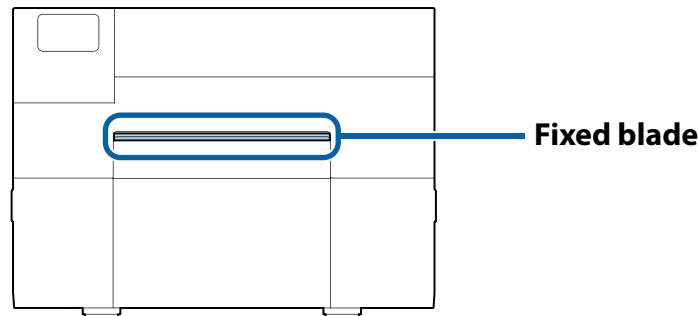

- 1 If paper has been loaded, remove it.
(👉 ["How to Remove Paper \(For the Auto Cutter Model\)"](#) on page 52)
- 2 Turn off the printer, and unplug the power cable.
- 3 As shown in the figure below, scrape off adhered materials stuck to the fixed blade using a flat-blade screwdriver (blade width: 1.8 mm to 3 mm). Start scraping from each end toward the center.

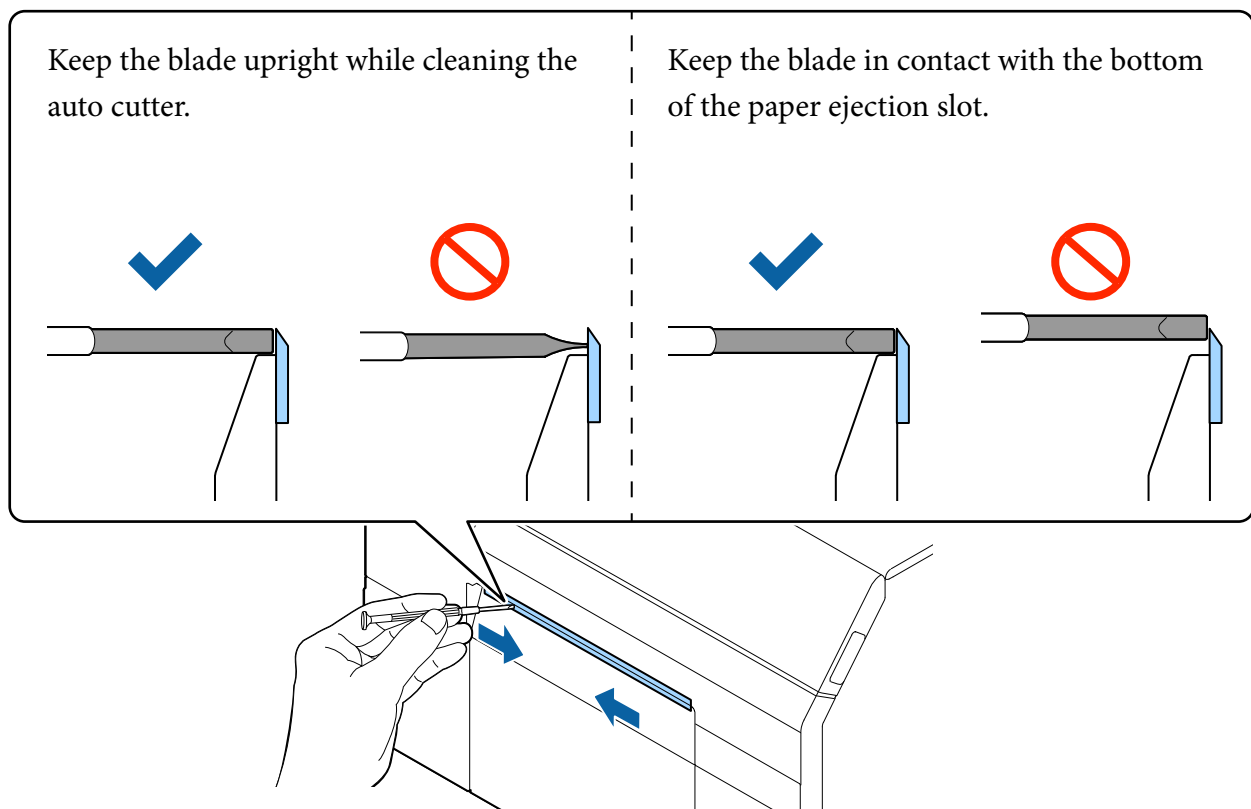

Cleaning the Peeler (Peeler Model Only)

If labels, paper dust, or adhesive has adhered to the peeler, the print quality may decline.

To maintain good print quality, it is recommended to clean the peeler every day.

Clean the peeler following the procedure below.

- 1 Make sure the printer has been turned off.
- 2 Open the peeler cover.
If paper has been loaded, remove it.
([🔗 "How to Remove Paper \(For the Peeler Model\)" on page 53](#))

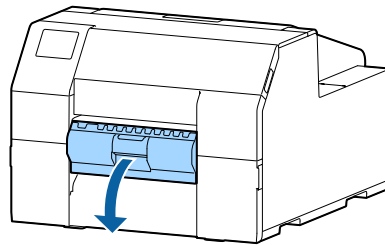

- 3 Clean the roller using a cotton swab moistened with alcohol.
Completely remove dirt from the roller.

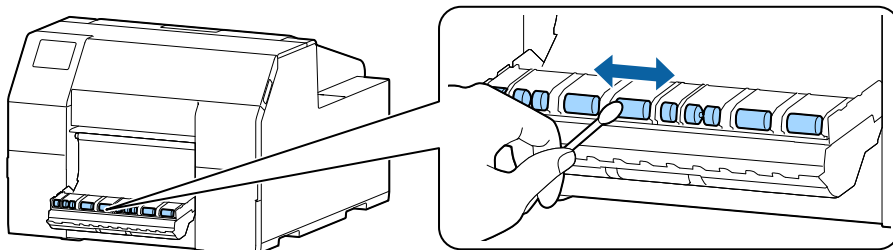

Cleaning the Edge Guides

If labels, paper dust, or adhesive has adhered to the edge guides, paper may get jammed, or printing position may become incorrect.

Clean the edge guides following the procedure below.

- 1 Make sure the printer has been turned off.
- 2 Open the paper cover.
If paper has been loaded, remove it.
([↩](#) "How to Remove Paper (For the Auto Cutter Model)" on page 52, "How to Remove Paper (For the Peeler Model)" on page 53)

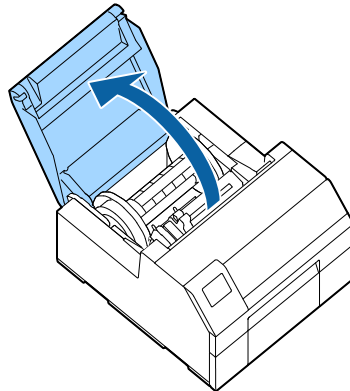

- 3 Clean the edge guides using a cotton swab moistened with alcohol.

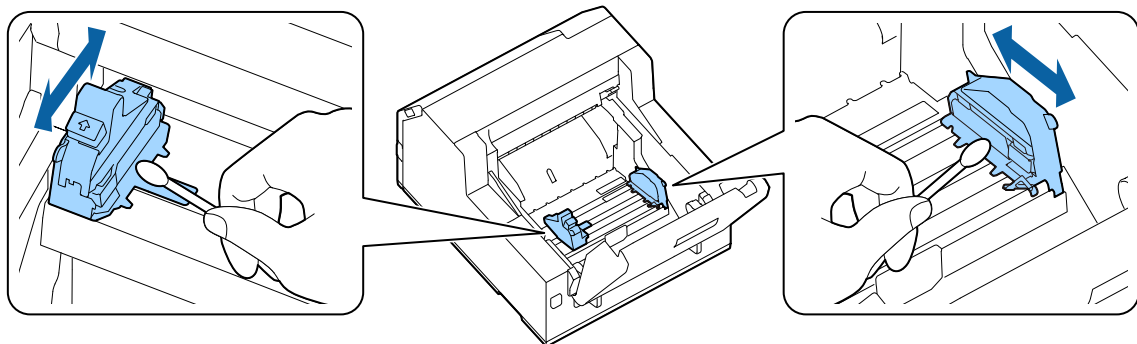

Cleaning the Platen

If labels, paper dust, or adhesive has adhered to the platen, paper may get jammed, or printing position may become incorrect.

Clean the platen following the procedure below.

- 1 Check that the printer has been turned off.
- 2 If paper has been loaded, remove it.
([☞ "How to Remove Paper \(For the Auto Cutter Model\)" on page 52, "How to Remove Paper \(For the Peeler Model\)" on page 53](#))

- 3 Open the front cover.

- 4 Raise the paper holder unit.

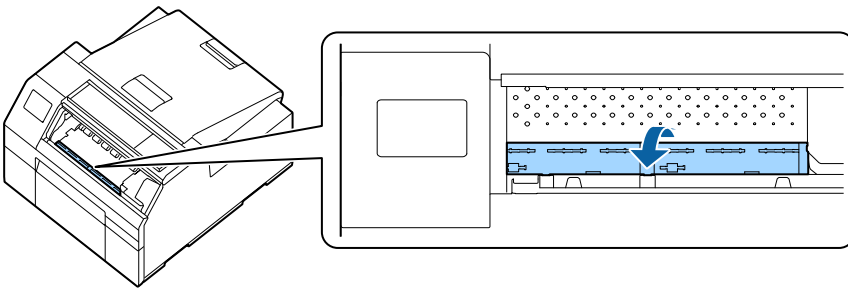

- 5 Use a cloth or cotton swab to remove adhesive adhered to the platen.

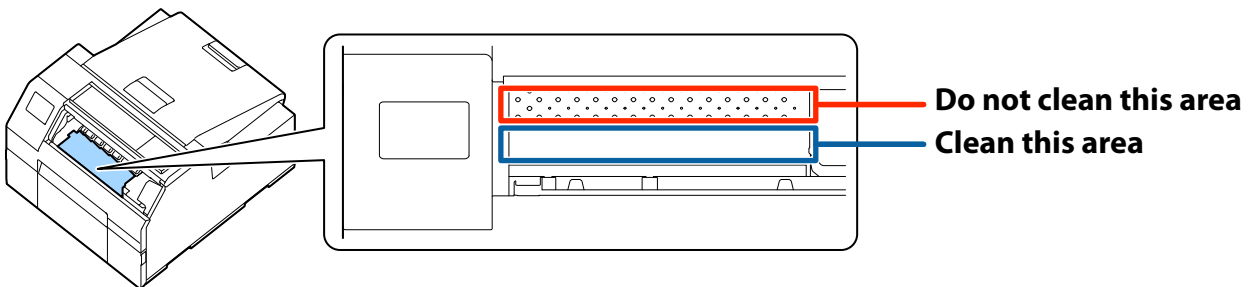

- 6 Lower the paper holder unit.

Cleaning the Paper Feed Roller

If paper dust or adhesive has adhered to the paper feed roller, paper may get jammed, or faint or blurred image may be printed.

Clean the roller following the procedure below.

CAUTION

When cleaning the paper feed roller, do not use a material other than labels. Doing so may damage the roller resulting in paper jam, or faint or blurred printout.

1 Check that the printer has been turned off.

2 Open the paper cover.

If paper has been loaded, remove it.

( "How to Remove Paper (For the Auto Cutter Model)" on page 52, "How to Remove Paper (For the Peeler Model)" on page 53)

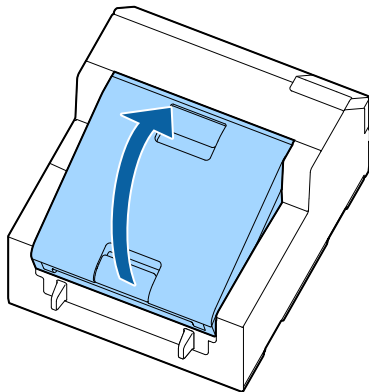

3 Remove the spindle.

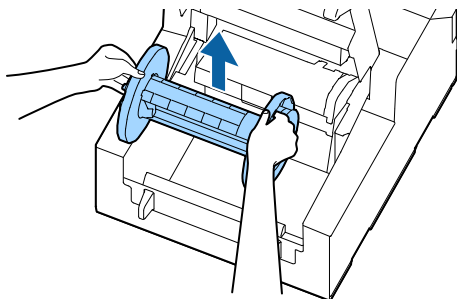

4 Raise the release lever.

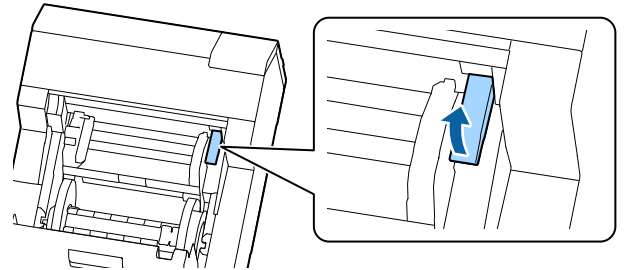

5 Open the paper guide unit.

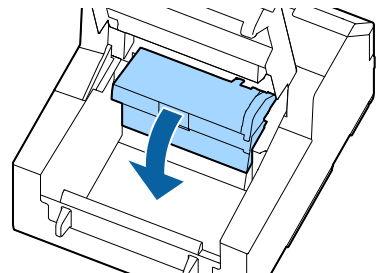

6 Attach adhesive side of a label to the roller, and peel it off slowly. Repeat this action until paper dust or adhesive is completely removed from side to side of the roller.

If some labels have stuck on the roller, carefully remove them as they can cause a paper jam.

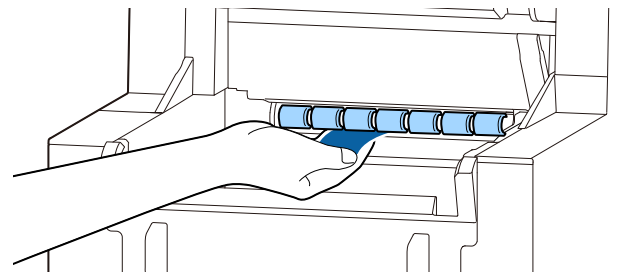

7 Rotating the roller by hand, remove paper dust or adhesive from entire surface of the roller.

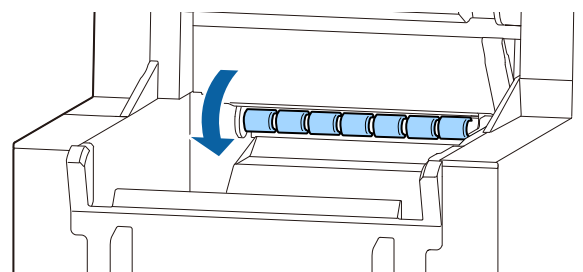

Cleaning the Paper Pressure Roller

If paper dust or adhesive has adhered to the paper pressure roller, paper may get jammed, or faint or blurred image may be printed.

Clean the roller following the procedure below.

CAUTION

When cleaning the paper pressure roller, do not use a material other than labels. Doing so may damage the roller resulting in paper jam, or faint or blurred printout.

1 Check that the printer has been turned off.

2 Open the paper cover.

If paper has been loaded, remove it.

( "How to Remove Paper (For the Auto Cutter Model)" on page 52, "How to Remove Paper (For the Peeler Model)" on page 53)

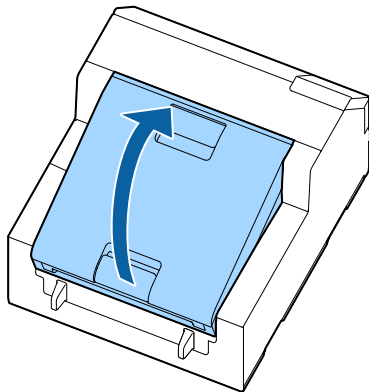

3 Remove the spindle.

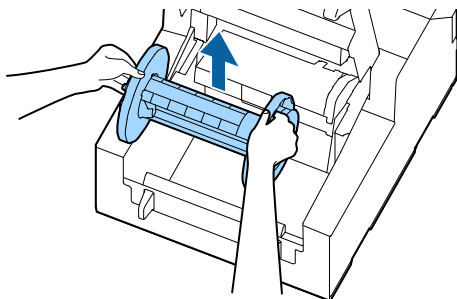

4 Raise the release lever.

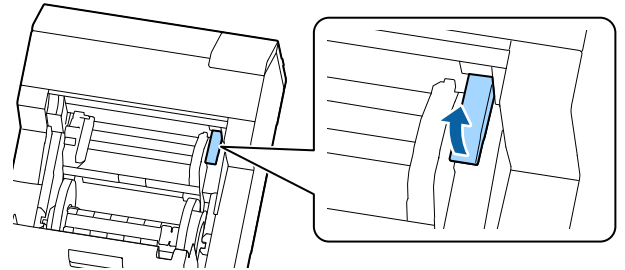

5 Open the front cover.

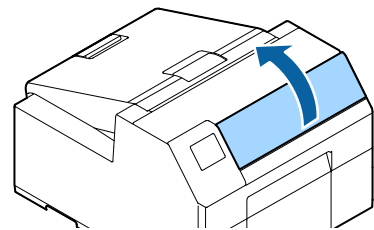

6 Attach adhesive side of a label to the roller, and peel it off slowly. Repeat this action until paper dust or adhesive is completely removed from side to side of the roller.

If some labels have stuck on the roller, carefully remove them as they can cause a paper jam.

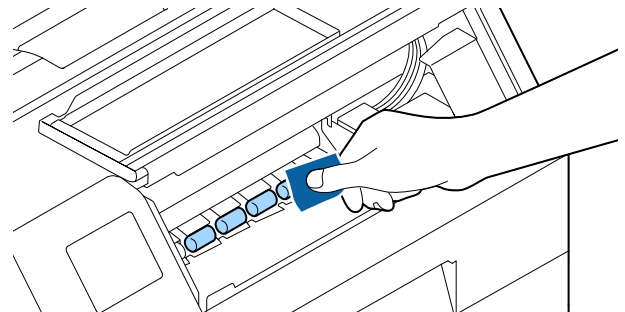

7 Rotating the roller by hand, remove paper dust or adhesive from entire surface of the roller.

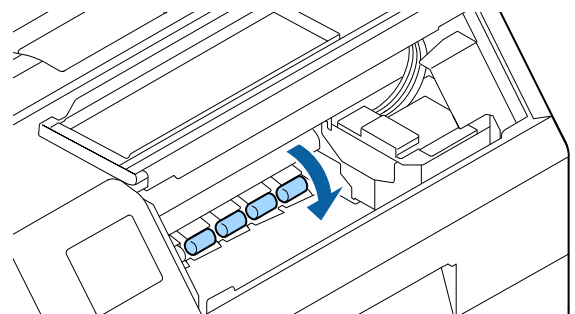

Cleaning the Print Head

If the nozzles are clogged, faint colors, banding, or unintended colors appear on printouts. When such print quality problems occur, print nozzle check patterns and check for nozzle clogging.

(🔗 "Printing Nozzle Check Patterns" on page 29)

Example of the nozzle check patterns with gloss black ink

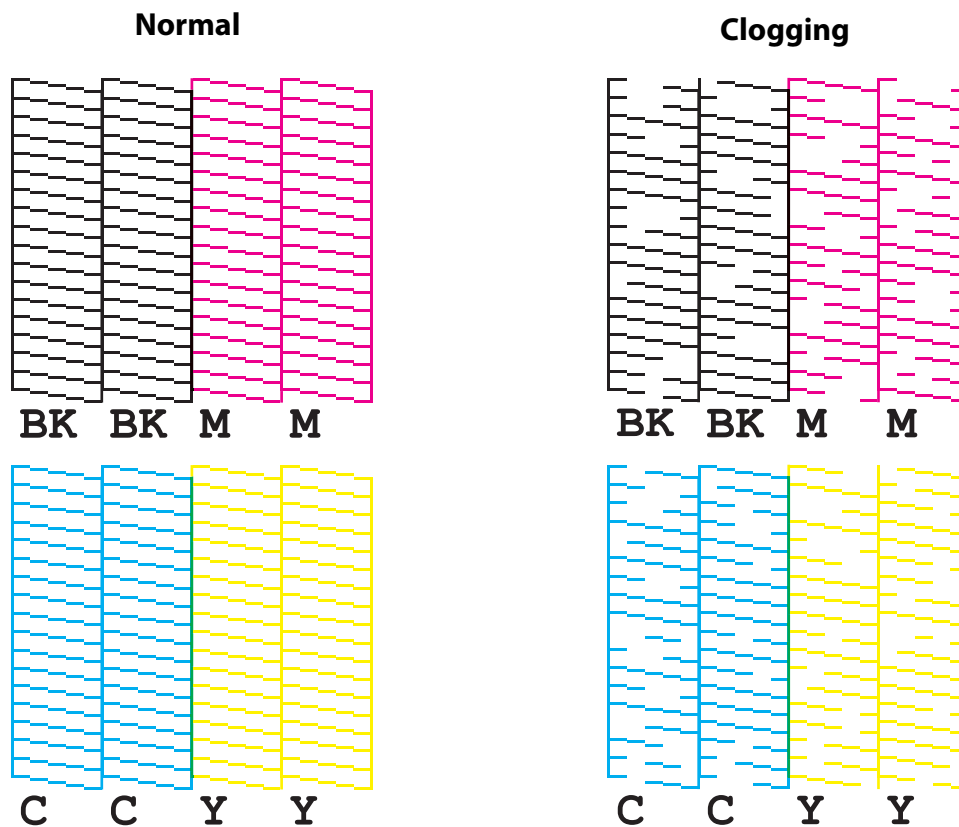

If nozzles are clogged, run a print head cleaning. To run a print head cleaning, select the menu as described below.

Run [Power Cleaning] only when nozzle clog is not cleared by running [Print Head Cleaning].



NOTE

The [Power Cleaning] consumes ink more than [Print Head Cleaning].

Using the Operation Panel

[Menu] - [Maintenance] - [Print Head Cleaning]

[Menu] - [Maintenance] - [Power Cleaning]

Using the Printer Driver

Click [Print Head Cleaning] or [Power Cleaning] on the [Printer Utilities] window.

Using the WebConfig

Select [Print Head Cleaning] on the [Maintenance] window. Then select the cleaning type from [Auto] or [Power Cleaning], and then click [Start].



NOTE

When logging in to WebConfig, you need to enter your user name and password. The initial values are as follows.

User name: Blank or a freely selected character string

Password: The value for "PASSWORD" on the label affixed to the rear of the product

Troubleshooting

This chapter describes how to resolve problems.

For troubleshooting information that is not described here, see the CW-C6000 Series/CW-C6500 Series Technical Reference Guide.

Paper is jammed

This section describes how to resolve the problem when the paper is jammed. This section is also explained with the help of a video. You can see the video from the link below.

<https://support.epson.net/p_doc/790/>

For the Auto Cutter Model

- 1** Cut the paper near the paper ejection slot.

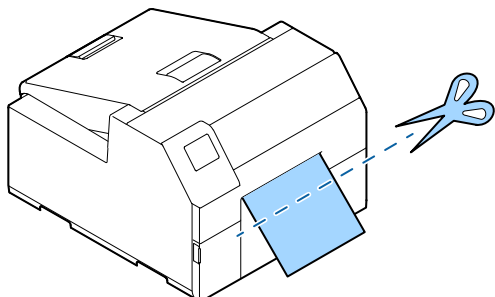

- 2** Open the front cover.

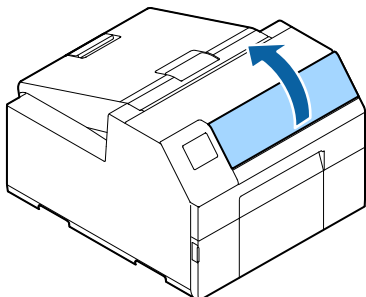

- 3** If there are ripped pieces of paper on the platen, remove them.

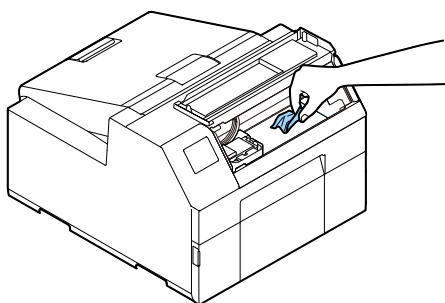

- 4** If the print head is not on the far right, hold it down and move it to the far right.
If there is jammed paper, remove it.

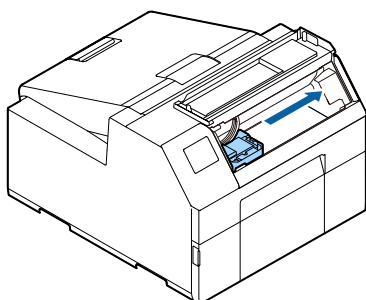

- 5** Open the paper cover.

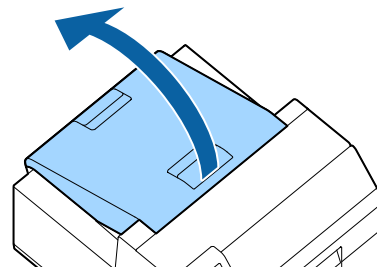

- 6** Raise the release lever.

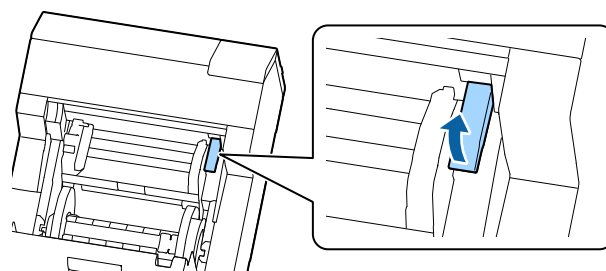

- 7** Pull the paper out from the paper feed slot.

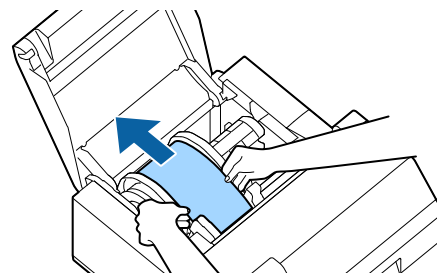

- 8** Lower the release lever.

- 9** Close the paper cover.

- 10** Close the front cover.

- 11** Press the Pause button.
The paper jam error will be cleared.

To resume printing, load the paper again.

(👉 "How to Load Paper (Auto Cutter Model - Supply from Inside)" on page 42, "How to Load Paper (Auto Cutter Model - Supply from Outside)" on page 45)

If the problem of paper jam cannot be resolved even after following the steps above, refer to the CW-C6000 Series/CW-C6500 Series Technical Reference Guide.

**NOTE**

After removing jammed paper, make sure that there is no labels or adhesive left inside the printer. If you use the printer without removing them, it leads to frequent paper jams, or may cause poor print quality. If paper jam occurs frequently, clean the inside of the printer.

([↶](#) "Maintenance" on page 56)

For the Peeler Model

- 1** Open the peeler cover.

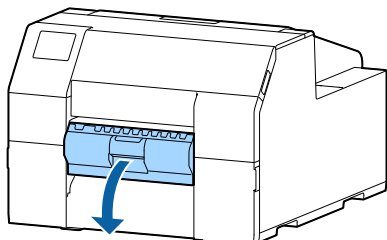

- 2** Cut the paper near the paper ejection slot.

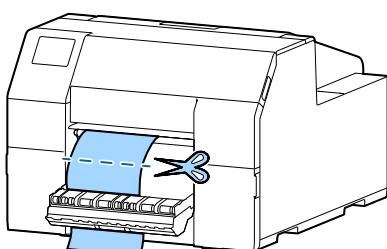

- 3** Open the front cover.

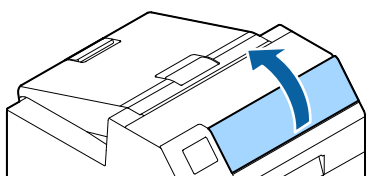

- 4** If there are ripped pieces of paper on the platen, remove them.

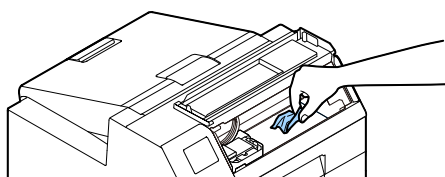

- 5** If the print head is not on the far right, hold it down and move it to the far right.
If there is jammed paper, remove it.

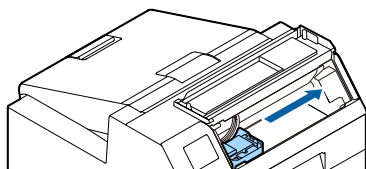

- 6** Open the paper cover.

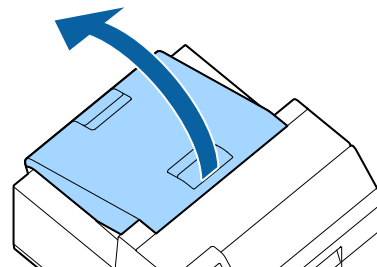

- 7** Raise the release lever.

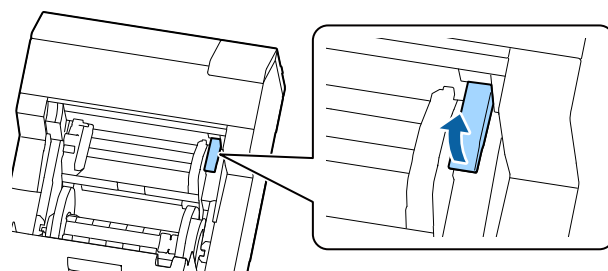

- 8** Pull the paper out from the paper feed slot.

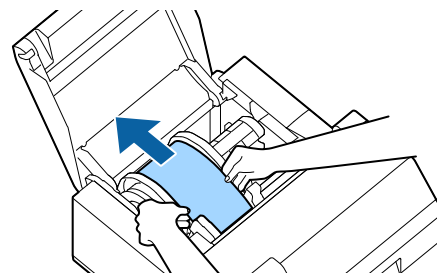

- 9** Lower the release lever.

- 10** Close the paper cover.

- 11** Close the front cover.

- 12** Close the peeler cover.

- 13** Press the Pause button.
The paper jam error will be cleared.

To resume printing, load the paper again.

(["How to Load Paper \(Peeler Model - Supply from Inside\)"](#) on page 48)

If the problem of paper jam cannot be resolved even after following the steps above, refer to the CW-C6000 Series/CW-C6500 Series Technical Reference Guide.

**NOTE**

After removing jammed paper, make sure that there is no labels or adhesive left inside the printer. If you use the printer without removing them, it leads to frequent paper jams, or may cause poor print quality. If paper jam occurs frequently, clean the inside of the printer.

([↶](#) "Maintenance" on page 56)

Problems with Print Quality

Horizontal White Banding

Cause	Solution and Reference
The nozzles are clogging.	<p>Print the nozzle check patterns to check the nozzles for clogging. (↗ "Printing Nozzle Check Patterns" on page 29)</p> <p>If the nozzles are clogging, run a print head cleaning. (↗ "Cleaning the Print Head" on page 64)</p>

Vertical White Spots (Auto Cutter Model)

Cause	Solution and Reference
The printed label has been back-fed.	<p>If printed labels are fed backward, the printed surface is damaged by the rollers located under the paper pressure unit.</p> <p>This can occur when the print mode is set to "Stop at Cut Position" or "Stop at Peel-Off Position", and printed labels have not been removed after each print job is finished.</p> <p>Select a print mode option other than "Stop at Cut Position" or "Stop at Peel-Off Position", or remove printed labels after each print job is finished.</p> <p>For details on the print modes, refer to the CW-C6000 Series/CW-C6500 Series Technical Reference Guide.</p>

White or Black Banding

Cause	Solution and Reference
The paper is not loaded correctly.	Reload the paper. (↗ "Loading and Replacing Paper" on page 41)
The paper being used and the Media Coating Type setting differ.	Check the paper being used and the Media Coating Type setting of the printer driver. (↗ "Printer Driver Settings" on page 35)

Printed Colors Are Wrong

Cause	Solution and Reference
If the printer is moved after initial charging, the specified colors may not be output (colors may be mixed) due to vibrations and impacts.	Run a head cleaning and check that colors are no longer mixed. (🔗 "Cleaning the Print Head" on page 64)

Print Position Shifts

Cause	Solution and Reference
The edge guide is not set along the paper edge.	Check that the edge guide is properly set at the paper width position. (🔗 "Loading and Replacing Paper" on page 41)
The paper you are using is set at an angle. (Peeler model)	Make sure that the edge of the paper is aligned with the protrusion below the peeler cover. (🔗 "Loading and Replacing Paper" on page 41)

Paper is Smearred or Smudged with Ink

Cause	Solution and Reference
The paper being used and the Media Coating Type setting differ.	Check the paper being used and the Media Coating Type setting of the printer driver. (🔗 "Printer Driver Settings" on page 35)
If foreign matter is adhered to the head, the paper may be smeared with ink.	Run a print head cleaning. (🔗 "Cleaning the Print Head" on page 64)

Paper is Fed and Ejected, and an Error Occurs

Cause	Solution and Reference
The paper being used differs from that of Media detection settings.	Check the paper being used and Media detection settings of the printer. (🔗 "Printer Driver Settings" on page 35)

Printing is Impossible or Becomes Suddenly Impossible

Print Data is Sent, But Does Not Print (Peeler Model)

Cause	Solution and Reference
The label peeling detector is malfunctioning.	If printing is performed at a location exposed to strong light such as direct sun rays, etc., the label peeling detector may not work properly, making it impossible to perform printing. Press the Peeler Reset button to cancel the non-printing state.

Printing from a computer is impossible or becomes suddenly impossible

Checking Whether the Printer Driver Is Installed

Check whether or not the required software and applications are installed on the computer.

To print with this printer, a printer driver is required. Check whether or not the printer driver is installed by following the steps below.

- 1 Display Devices and Printers on the computer.
- 2 Check that the printer name is displayed.
If not, the printer driver is not installed.
- 3 Install the printer driver.
([🔗](#) "Downloading the Latest Version" on page 4)

The printer does not turn on

Check that the power cable is connected to the printer and outlet properly. ([🔗](#) "Rear" on page 21).

Print Job is Canceled on PC but "Printing" Message on Printer Does Not Disappear

If you cancel printing in printer queue on the computer, it may cause the print data to break up and "Printing" may be kept displayed on the operation panel of the printer.

To cancel the status, press the Cancel button on the operation panel, and then select [All label formats].

A Message is Displayed on the Operation Panel

Message	Solution and Reference
<p>Information Paper feed error. Load the paper or change the media source setting.</p>	<p>Use paper that matches the [Media Source] and [Media Form] settings. Or change the [Media Source] and [Media Form] settings to match them with the loaded paper. (🔗 "Printer Driver Settings" on page 35)</p>
<p>Information Cannot detect the roll paper. Reload the paper or change the media detection setting.</p>	<p>Use paper that matches the [Media Detect] settings. Or change the [Media Detect] settings to match them with the loaded paper. (🔗 "Printer Driver Settings" on page 35)</p>
<p>Information Cannot detect the fanfold paper. Reload the paper or change the media detection setting.</p>	<p>Use paper that matches the [Media Detect] settings. Or change the [Media Detect] settings to match them with the loaded paper. (🔗 "Printer Driver Settings" on page 35)</p>
<p>(On the home screen) Load paper.</p>	<p>Load paper. (🔗 "Loading and Replacing Paper" on page 41)</p>
<p>Information The paper size set in the printer may differ from the print setting.</p>	<p>Load media that matches the print area size. Or change the print area to match it with the media size. (🔗 "Loading and Replacing Paper" on page 41)</p>
<p>Information The roll paper is not loaded.</p>	<p>Load roll paper. (🔗 "Loading and Replacing Paper" on page 41)</p>
<p>Information The fanfold paper is not loaded.</p>	<p>Load fanfold paper. (🔗 "Loading and Replacing Paper" on page 41)</p>
<p>Information Paper jam.</p>	<p>Remove the jammed paper and then load paper. (🔗 "Paper is jammed" on page 66)</p>
<p>Information The paper is not loaded correctly. Remove the paper from the top of the paper guide, close the paper cover, and then press the Pause button.</p>	<p>Remove the paper, and then load the paper again. See "How to Eject Paper at Paper End (For the Auto Cutter Model)" on page 54 or "How to Eject Paper at Paper End (For the Peeler Model)" on page 55, and "Loading and Replacing Paper" on page 41. If the above step does not clear the error, check the position of the gap detector. For details on how to operate the detectors, refer to the CW-C6000 Series/ CW-C6500 Series Technical Reference Guide.</p>

Message	Solution and Reference
<p>Information</p> <p>Calibration failed.</p> <p>Press the OK button. Then reload or replace the paper.</p>	<p>Make sure that the paper loaded in the printer matches the paper detection method (gap or black mark), and reset the paper. (☞ "Loading and Replacing Paper" on page 41)</p> <p>If the error still occurs, the detector cannot handle the paper. Replace the paper.</p>
<p>Information</p> <p>The paper has already been cut and cannot be cut.</p>	<p>This error occurs when you press the Cut button at the position where the paper is already cut.</p> <p>Feed the paper by printing or pressing the Feed button to enable the Cut button.</p>
<p>Maintenance Error</p> <p>The ink cartridge is not installed correctly.</p>	<p>Install an ink cartridge with a sufficient amount of ink remaining. (☞ "Replacing the Ink Cartridges" on page 31)</p>
<p>(On the home screen, an exclamation mark on the ink levels)</p>	<p>Prepare a new ink cartridge to be replaced with the low-ink-level cartridge. If you continue to use the low-ink-level cartridge, you may be required to replace it during printing.</p> <p>If you replace the cartridge during printing, you may see a difference in color between colors printed by the old cartridge and colors printed by the new one due to a difference in ink drying status.</p> <p>If it is not acceptable for you, replace the ink cartridge with a new one before starting printing. (☞ "Replacing the Ink Cartridges" on page 31)</p> <p>The removed ink cartridge can be installed again and used until you are prompted to replace it.</p>
<p>Information</p> <p>You need to replace Ink Cartridge(s).</p>	<p>Install an ink cartridge with a sufficient amount of ink remaining. (☞ "Replacing the Ink Cartridges" on page 31)</p>
<p>Maintenance Error</p> <p>Cannot recognize the ink cartridge.</p> <p>Select "Next" to clear the error.</p>	<p>Reinstall the ink cartridge.</p> <p>If the error reoccurs, replace the ink cartridge with a new one. (☞ "Replacing the Ink Cartridges" on page 31)</p>
<p>Information</p> <p>You have not installed genuine Epson ink cartridges.</p>	<p>For the best performance of the printer, it is recommended to use genuine Epson ink cartridges. Use of non-genuine Epson ink cartridges can adversely affect the printer and print quality and prevent the printer from realizing its maximum performance. Epson cannot guarantee the quality and reliability of non-genuine Epson products. Repairs for any damage or breakdown of this product due to the use of non-genuine Epson products will not be free of charge even if the warranty period is still valid.</p>
<p>Information</p> <p>This ink cartridge is inapplicable.</p>	<p>Because the installed ink cartridges are not the ones for this printer, an error such as a cartridge detection error may occur.</p>

Message	Solution and Reference
<p>Maintenance Error A maintenance box is not installed. Model number: SJMB6000/ 6500</p>	<p>Install a new maintenance box. (🔗 "How to Replace the Maintenance Box" on page 34)</p>
<p>Maintenance Error Cannot recognize the maintenance box. Model number: SJMB6000/ 6500</p>	<p>Reinstall the maintenance box. If the error reoccurs, replace the maintenance box with a new one. (🔗 "How to Replace the Maintenance Box" on page 34)</p>
<p>(On the home screen) The Maintenance Box is nearing end of its service life.</p>	<p>Prepare a new maintenance box to be replaced with the near-full maintenance box. When a message saying "The Maintenance Box is at the end of its service life. You need to replace it." is displayed, replace the maintenance box. (🔗 "How to Replace the Maintenance Box" on page 34)</p>
<p>Maintenance Error The Maintenance Box is at the end of its service life. You need to replace it. Model number: SJMB6000/ 6500</p>	<p>Replace the maintenance box with a new one. (🔗 "How to Replace the Maintenance Box" on page 34)</p>
<p>Information Memory Full. Document was not printed.</p>	<p>Delete unnecessary files.</p>
<p>Printer Error Turn on the printer again. See your documentation for more details. XXXXXX</p>	<p>1. Turn off the printer. 2. Check that there is no paper jam or foreign materials near the ejection slot. 3. Turn the printer on. If the printer error still occurs, contact qualified service personnel for advice. When contacting, tell the person the "XXXXXXXX" (a 6- or 8-digit alphanumeric code).</p>
<p>Information Cannot start cleaning because ink is low. Printer features except cleaning are available.</p>	<p>When running the cleaning, install ink cartridges with a sufficient amount of ink remaining. (🔗 "Replacing the Ink Cartridges" on page 31)</p>
<p>Information Remove the label.</p>	<p>Remove the labels from the peeler. If the error is not cleared, press the Peeler Reset button.</p>

Message	Solution and Reference
<p>Information Paused The print quality may decrease because the nozzles are clogged.</p>	<p>The print quality may decrease because the nozzles are clogged. If it is not acceptable, run a print head cleaning. (🔗 "Cleaning the Print Head" on page 64)</p>
<p>Information Open front cover, and close paper hold unit.</p>	<p>Open the front cover, and then close the paper holder unit. When the paper holder unit is opened, a paper jam error may occur. If the paper jam error is not cleared, try the solutions in the links below. Auto cutter model: "For the Auto Cutter Model" on page 67 Peeler model: "For the Peeler Model" on page 69</p>

Specifications

This chapter describes the specifications of the printer.

Specification

Item		CW-C6000 Series	CW-C6500 Series	
Printing method		Serial inkjet, dot matrix method Four-color printing		
Paper feed method		Forward and reverse friction feed		
Cutting type of the auto cutter (Auto cutter model only)		Full cut (cuts paper completely)		
Print density		300 × 600 dpi, 600 × 600 dpi 600 × 1200 dpi, 1200 × 1200 dpi		
Print speed	Print quality setting: Max Speed 300 × 600 dpi (width × height)	Printing width: 25.4 mm	156 mm/s	156 mm/s
		Printing width: 101.6 mm	119 mm/s	119 mm/s
		Printing width: 203.2 mm	-	85 mm/s
	Print quality setting: Speed 600 × 600 dpi (width × height)	Printing width: 25.4 mm	125 mm/s	125 mm/s
		Printing width: 101.6 mm	75 mm/s	75 mm/s
		Printing width: 203.2 mm	-	49 mm/s
	Print quality setting: Normal 600 × 600 dpi (width × height)	Printing width: 25.4 mm	63 mm/s	63 mm/s
		Printing width: 101.6 mm	48 mm/s	48 mm/s
		Printing width: 203.2 mm	-	34 mm/s
	Print quality setting: Quality 600 × 1200 dpi (width × height)	Printing width: 25.4 mm	27 mm/s	27 mm/s
		Printing width: 101.6 mm	18 mm/s	18 mm/s
		Printing width: 203.2 mm	-	13 mm/s

Item			CW-C6000 Series	CW-C6500 Series
Print speed	Print quality setting: Max Quality 1200 × 1200 dpi (width × height)	Printing width: 25.4 mm	11 mm/s	11 mm/s
		Printing width: 101.6 mm	8 mm/s	8 mm/s
		Printing width: 203.2 mm	-	6 mm/s
Interface			Wired LAN (1000BASE-T/100BASE-TX /10BASE-T) USB2.0 High-Speed	
Weight	Auto cutter model		Approx. 22.5 kg	Approx. 25.5 kg
	Peeler model		Approx. 22.8 kg	Approx. 26.3 kg

Electrical Specifications

Item		CW-C6000 Series	CW-C6500 Series
Power supply		Power supply through a power connector	
Rated voltage		100 to 240 V	
Rated current		0.9 A	
Power consumption	Operating	100V: Average of approx. 39.4 W 230V: Average of approx. 38.6 W	100V: Average of approx. 39.5 W 230V: Average of approx. 38.7 W
	Standby	100V: Average of approx. 7.51 W 230V: Average of approx. 5.82 W	100V: Average of approx. 7.51 W 230V: Average of approx. 5.82 W
	Power off	100V: Average of approx. 0.08 W 230V: Average of approx. 0.24 W	100V: Average of approx. 0.08 W 230V: Average of approx. 0.24 W

Overall Dimensions

Item	CW-C6000 Series	CW-C6500 Series
Height	326 mm	326 mm
Width	340 mm	444 mm
Depth	565 mm (Excludes the protrusion)	515 mm (Excludes the protrusion)

Environmental Specifications

Temperature/ humidity	Printing	5 to 35°C, 20 to 80% RH (no condensation)	
	Barcode printing	15 to 35°C, 20 to 80% RH (no condensation)	
	Storage	When packed (ink not charged)	-20 to 60°C, 5 to 85% RH without condensation (When -20°C or 60°C, within 120 hours)
	With ink charged	Gloss Black ink	-15 to 40°C, 20 to 85% RH without condensation (When -15°C, within 120 hours) (When 0 to 25°C, within 6 month) (When 40°C, within 1 month)
		Matte Black ink	-10 to 40°C, 20 to 85% RH without condensation (When -10°C, within 120 hours) (When 0 to 25°C, within 6 month) (When 40°C, within 1 month) Can be stored at -20°C by discharging ink in advance.
Elevation	0 to 3000 m		
Noise	Auto cutter model: Approx. 55 dB Peeler model: Approx. 60 dB Based on Epson evaluation conditions.		

Paper Specifications

The following types of paper can be used with the printer.

Black ink type	Supported paper
Gloss black ink	Matte Paper Synthetic Glossy Paper Glossy Film High Glossy Paper
Matte black ink	Plain Paper Matte Paper Synthetic Texture Paper

Ink Cartridge

Model number	CW-C6000Au, CW-C6000Pu CW-C6500Au, CW-C6500Pu	SJIC35P-BK/SJIC35P-MK/SJIC35P-C/SJIC35P-M/SJIC35P-Y
	CW-C6000Ae, CW-C6000Pe CW-C6500Ae, CW-C6500Pe	SJIC36P-BK/SJIC36P-MK/SJIC36P-C/SJIC36P-M/SJIC36P-Y
	CW-C6010A, CW-C6010P CW-C6510A, CW-C6510P	SJIC36P-BK/SJIC36P-MK/SJIC36P-C/SJIC36P-M/SJIC36P-Y
	CW-C6020A, CW-C6020P CW-C6520A, CW-C6520P	SJIC37P-BK/SJIC37P-MK/SJIC37P-C/SJIC37P-M/SJIC37P-Y
	CW-C6030A, CW-C6030P CW-C6530A, CW-C6530P	SJIC38P-BK/SJIC38P-MK/SJIC38P-C/SJIC38P-M/SJIC38P-Y
	CW-C6040A, CW-C6040P CW-C6540A, CW-C6540P	SJIC39P-BK/SJIC39P-MK/SJIC39P-C/SJIC39P-M/SJIC39P-Y
	CW-C6050A, CW-C6050P CW-C6550A, CW-C6550P	SJIC40P-BK/SJIC40P-MK/SJIC40P-C/SJIC40P-M/SJIC40P-Y
Type	4 individual color cartridges	
Ink colors	Black (gloss black (BK), matte black (MK)), cyan (C), magenta (M), yellow (Y)	
Ink type	Pigmented ink	
Expiration date	6 months after installation in the printer, 3 years after manufacture including the period of use	
Storage temperature	Transporting (without unpacking)	-20 to 60°C (within 5 days when 60°C)
	Storage (without unpacking)	-20 to 40°C (within 1 month when 40°C)
	Installed	-20 to 40°C (within 1 month when 40°C)

Maintenance Box

Model number	SJMB6000/6500	
Type	Maintenance box with integrated waste ink absorbing material	
Storage temperature	Transporting (without unpacking)	-20 to 60°C (within 5 days when 60°C)
	Storage (without unpacking)	-20 to 40°C (within 1 month when 40°C)
	Installed	-20 to 40°C (within 1 month when 40°C)

Appendix

Consumables and Options

Consumables and options for this product are available. They can be purchased from sales representatives.

Visit the URL below for more details.

< <https://www.epson.com/support/> >

Ink Cartridge

Four ink cartridge colors are used. Black ink can be selected from gloss black and matte black.*

For the ink cartridges that can be used with this product, refer to "Ink Cartridge" on page 83.

Replace the ink cartridge(s) when you are prompted to do so.

(🔗 "Replacing the Ink Cartridges" on page 31)

* Some models of the printer cannot use matte black ink.

Genuine Ink Cartridges Recommended

- For the best performance of the printer, it is recommended to use genuine Epson ink cartridges. Use of non-genuine Epson ink cartridges can adversely affect the printer and print quality and prevent the printer from realizing its maximum performance. Epson cannot guarantee the quality and reliability of non-genuine Epson products. Repairs for any damage or breakdown of this product due to the use of non-genuine Epson products will not be free of charge even if the warranty period is still valid.
- Color adjustment of the product is based on the use of genuine Epson ink cartridges. Use of non-genuine ink cartridges may result in reduced print quality. Epson recommends the use of genuine Epson ink cartridges.

Disposal of Ink Cartridges

Dispose the ink cartridges properly following the law or regulations of your country and area.

Maintenance Box

The maintenance box is a box used to collect waste ink. The maintenance box available for this product is:
Model number: SJMB6000/6500

Replace the maintenance box when you are prompted to do so.

([↶](#) "Replacing the Maintenance Box" on page 33)

Genuine Maintenance Box Recommended

For the best performance of the printer, it is recommended to use a genuine Epson maintenance box. Use of a non-genuine Epson maintenance box can adversely affect the printer and prevent the printer from realizing its maximum performance. Repairs for any damage or breakdown of this product due to the use of non-genuine Epson products will not be free of charge even if the warranty period is still valid. Epson cannot guarantee the quality and reliability of non-genuine Epson products.

Disposal of Maintenance Box

Dispose the maintenance box properly following the law or regulations of your country and area.

Roll Paper Holder

A spare roll paper holder is provided as an option. In the following cases, replacement of the roll paper can be performed quickly by loading paper beforehand in the spare roll paper holder.

- When you want to use paper of a different size or frequently change the label material
- When you want to reduce the down time as a result of roll paper replacement

Model number:

- Paper Holder C6000 (for CW-C6000 Series)
- Paper Holder C6500 (for CW-C6500 Series)

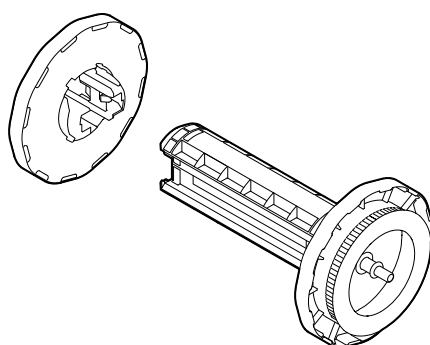

Item	Paper Holder C6000	Paper Holder C6500
External dimensions (H x W x D)	220 × 206 × 220 mm	175 × 310 × 175 mm
Weight	0.65 kg	0.65 kg

Restriction of Use

When this product is used for applications requiring high reliability/safety such as transportation devices related to aviation, rail, marine, automotive etc.; disaster prevention devices; various safety devices etc.; or functional/precision devices etc., you should use this product only after giving consideration to including fail-safes and redundancies into your design to maintain safety and total system reliability. This product is not intended for use in applications requiring an extremely high level of reliability and safety, such as in aerospace instruments, main communication equipment, nuclear power control equipment, or medical equipment, etc. Please make your own judgment on this product's suitability after a full evaluation.

Notes

- (1) All rights reserved. No part of this publication may be reproduced, stored in a retrieval system, or transmitted in any form or by any means, electronic, mechanical, photocopying, recording, or otherwise, without the prior written permission of Seiko Epson Corporation.
- (2) The content of this manual is subject to change without notice.
- (3) While every precaution has been taken in the preparation of this manual, Seiko Epson Corporation assumes no responsibility for errors or omissions.
- (4) Neither is any liability assumed for damages resulting from the use of the information contained herein.
- (5) Neither Seiko Epson Corporation nor its affiliates shall be liable to the purchaser of this product or third parties for damages, losses, costs, or expenses incurred by purchaser or third parties as a result of: accident, misuse, or abuse of this product or unauthorized modifications, repairs, or alterations to this product, or (excluding the U.S.) failure to strictly comply with Seiko Epson Corporation's operating and maintenance instructions.
- (6) Seiko Epson Corporation shall not be liable for any damages or problems arising from the use of any options or any consumable products other than those designated as Genuine Epson Products or Epson Approved Products by Seiko Epson Corporation.

Trademarks

Microsoft®, Windows®, Windows Vista®, and Windows Server® are registered trademarks of Microsoft Corporation in the United States and/or other countries.

EPSON is a registered trademark of Seiko Epson Corporation. Exceed Your Vision is a registered trademark or trademark of Seiko Epson Corporation.

All other trademarks are the property of their respective owners and used for identification purpose only.

©Seiko Epson Corporation 2019-2022.