

X30M-E 自动调焦版

电子对焦/手动对焦可选  
快节奏条码精准读取

ELECTRONIC FOCUS / MANUAL FOCUS OPTIONAL  
FAST PACED BAR CODE ACCURATE READING



## X30M系列 百万像素工业扫码器

Megapixel industrial scanner



1D / 2D



高速扫描



大视野



“超扫”解码



外壳防护



ESD防护

### 性能优势：

- 内置高性能解码芯片，“解码帧率”最高120fps  
轻松解决各行业运动读码需求(烟草行业、食品行业、医疗检测行业等)
- 超高速识别烟草QR码、医疗试管码等，移动容差可达6m/s，读码成功率达99.999%
- 130万像素背照式高感CMOS，低照度下稳定成像
- 支持电子自动对焦，现场调试更方便
- 高效照明系统，发热更小，照明更亮更均匀



X30M-A 手动调焦版

可有效读取DPM码/标签码/  
喷码/屏幕码等工业特殊条码  
适用于工业自动化等行业



## X30M-A/E 技术规格书 / Technical specification

### 物理参数 / Physical Characteristics

尺寸/Dimensions:	65mm x 47mm x 47.3mm
重量/Weight:	321.6g
外壳材质/Housing Material:	锌合金
供电&功耗/Power supply & consumption	5-30VDC / 5W max

### 识读参数 / Performance Characteristics

图像传感器/Image(Pixels):	全局快门, 1280x1080, 120FPS
最大采集速率/HZ:	120帧/秒
光源/Light Source:	漫反射照明, 远近+偏振光, 4组光源, 独立控制, 红, 白, 蓝, 3色光源板配件可切换
视场角度/FOV:	4mm(50°) / 6mm(35°) / 8.5mm(25°) / 12mm(18°) / 16mm(13.5°) / 25mm(8.5°)
对焦方式/Focusing Mode:	X30M-A:机械对焦(调焦旋钮手动对焦) X30M-E:电子自动对焦(安装调校阶段可按条件自动调整)
移动容差/Movement Tolerance:	QR: >6m/sec, DataMatrix: >3m/sec
通讯/Interface:	RS232,USB,以太网 (TCP/UDP),RS485,支持SuperLink组网协议,Modbus协议
识读码制 Decode Capability:	一维条码/1D: Code128, Code93, Code39, Interleaved 2 of 5, Industrial 2 of 5, JAN/EAN/UPC 二维条码/2D: QR, DataMatrix, PDF417, Aztec
外部输入/External Input:	2路光电隔离输入, 可接NPN/PNP/继电器
外部输出/External Output:	3路光电隔离输出

### 用户环境 / User Environment

温度范围/Temperature Range:	工作温度:0°C~50°C, 存储温度:-20°C~70°C
外壳防护/Housing IP:	IP65
跌落/Drop Resistance:	1.2米水泥地面, 自由落体, 6面 x 5次/面=30次
ESD防护/ESD Protection:	接触放电±8KV, 耦合放电±8KV, 空气±15KV
环境光免疫/Ambient Light Immunity:	100.000 Lux.

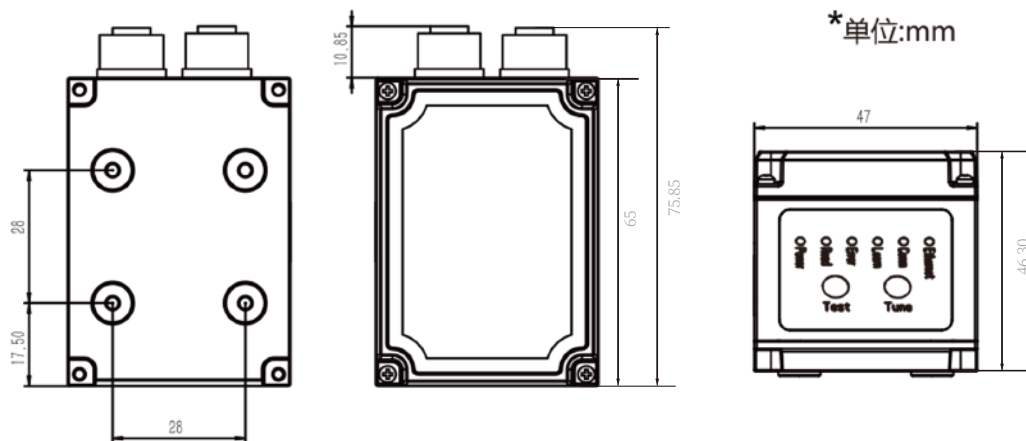

## 6mm焦距

码制	精度	距离
一维码 1D	3mil	30mm-120mm
	5mil	25mm-225mm
	7.5mil	25mm-320mm
二维码 2D	5mil	25mm-125mm
	7.5mil	25mm-175mm
	10mil	25mm-250mm

视野	25mm	22mmx18mm
	400mm	230mmx195mm

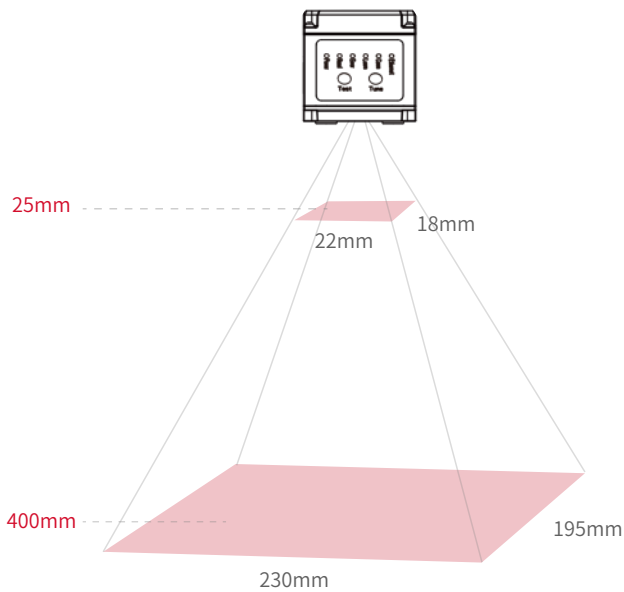

## 12mm焦距

码制	精度	距离
一维码 1D	3mil	50mm-150mm
	5mil	50mm-300mm
	7.5mil	50mm-400mm
二维码 2D	5mil	50mm-200mm
	7.5mil	50mm-300mm
	10mil	50mm-400mm

视野	50mm	17mmx14mm
	400mm	118mmx99mm

